

---

**INSTRUCTION BOOK**  
**FOR**  
**RADIO RECEIVER R-520/URR**

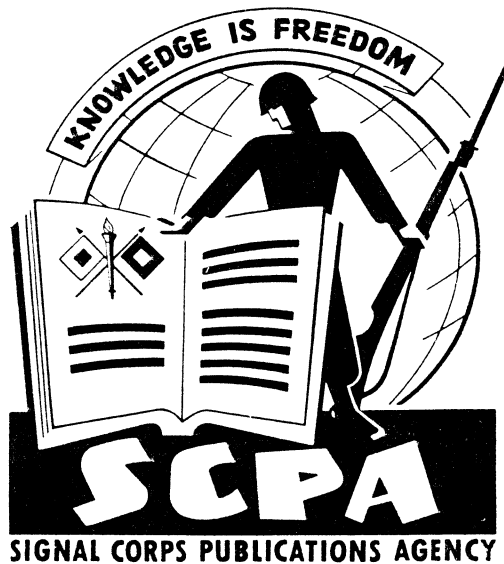

---

**MANUFACTURED BY**  
**ZENITH RADIO CORPORATION**  
**CHICAGO, ILLINOIS**

**ORDER NO. 15175-PHILA-52-01**

**26 January 1953**

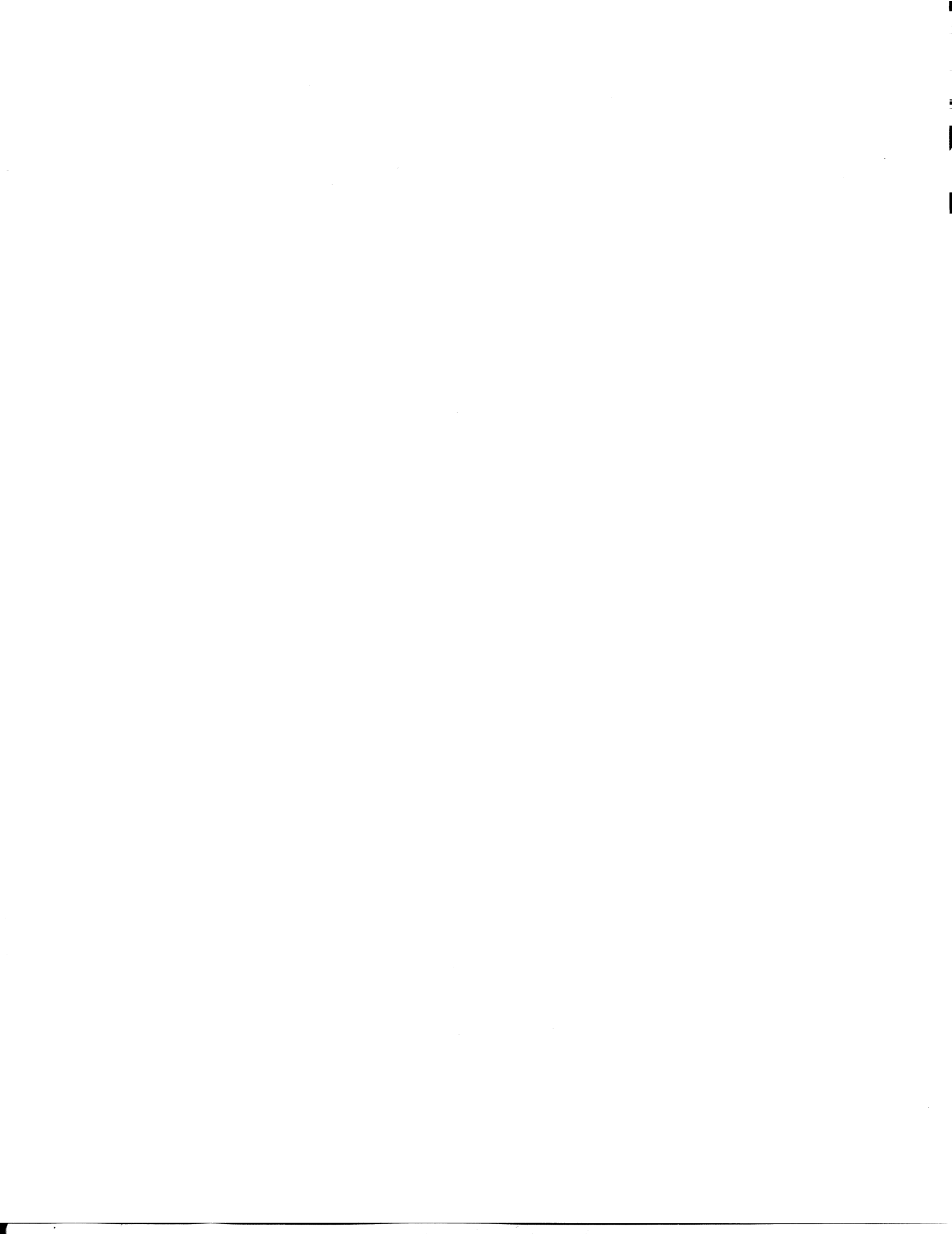

---

**INSTRUCTION BOOK**  
**FOR**  
**RADIO RECEIVER R-520/URR**

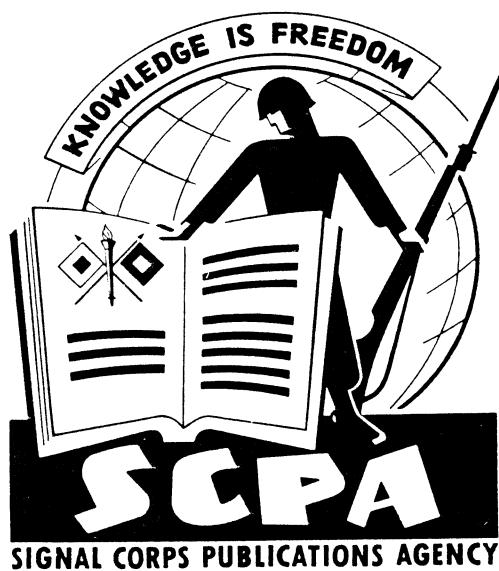

---

**MANUFACTURED BY**  
**ZENITH RADIO CORPORATION**  
**CHICAGO, ILLINOIS**

**ORDER NO. 15175-PHILA-52-01**

**26 January 1953**

## **WARNING**

### **HIGH VOLTAGE**

is used in the operation  
of this equipment.

### **A DANGEROUS SHOCK**

may result if operating personnel fail  
to observe safety precautions.

---

Be careful not to contact external power  
source input connections when working on  
or near this equipment.

---



# ADDENDA TO INSTRUCTION BOOK

JANUARY 26, 1953

## **RADIO RECEIVER R-520/URR**

The following information supplements the instruction book for Radio Receiving Set R-520/URR. The serial numbers of the radio receivers covered in this addenda are:

NAME	SERIAL NUMBERS
Radio Receiver R-520/URR	2550 through 7217

Page 139. App. 11 Par. 2. Add the following after item 6:

Ref. symbol	Name of part and description
R25 (Order No. 15175- PH-52-01, serial numbers 2550 through 7217)	RESISTOR, fixed: comp; 47 ohms ±10%; ½w; JAN type RC20BF- 470K

Page 152-A. Add the following to the caption of figure 40:

(In Radio Receiver R-520/URR bearing Order No. 15175-PH-52-01 serial numbers 2550 through 7217, the value of resistor R25 is changed from 150 ohms to 47 ohms.)

FEBRUARY 3, 1953

202G3023

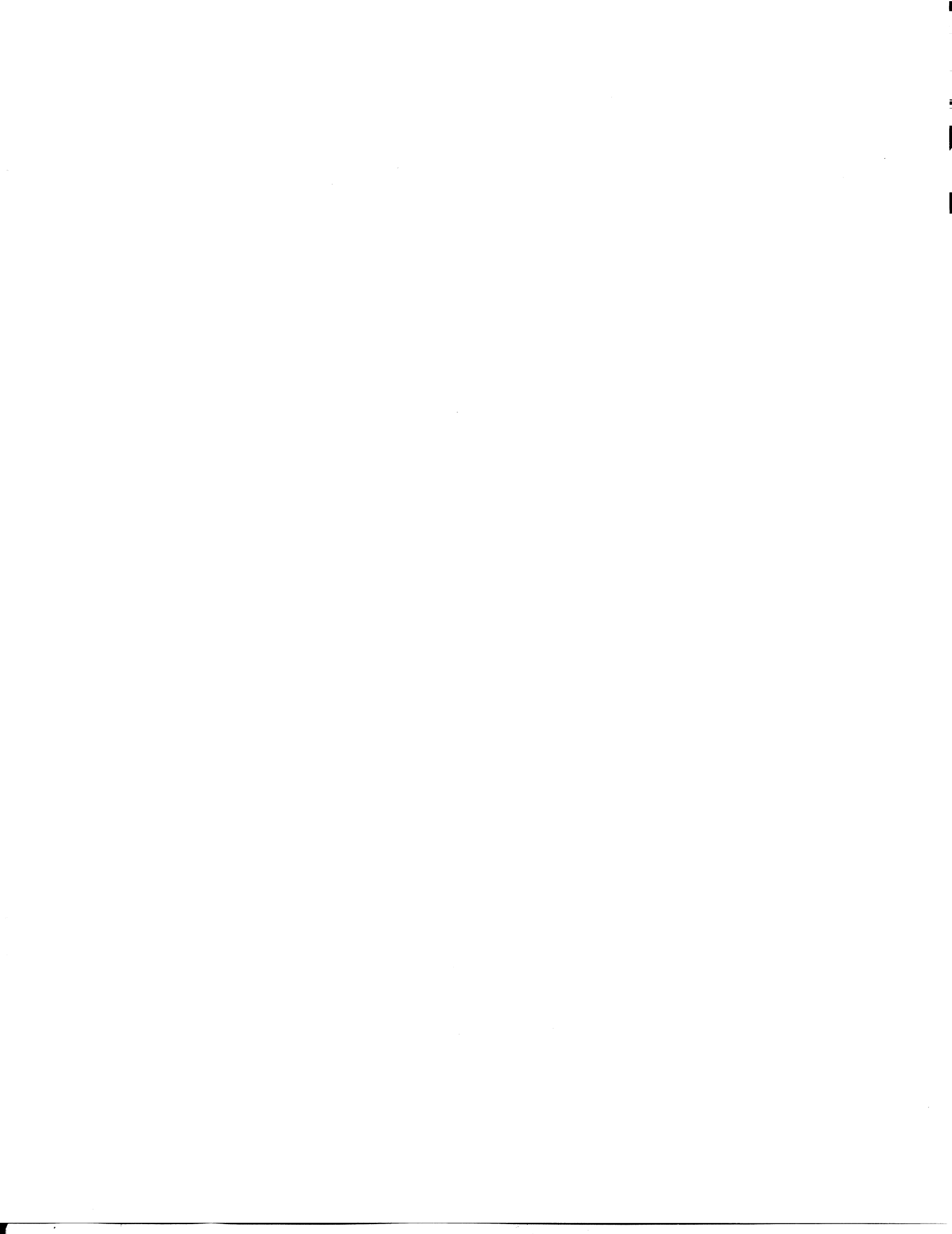

# CONTENTS

---

	<i>Paragraph</i>	<i>Page</i>
<b>CHAPTER 1. INTRODUCTION</b>		
<i>Section I. General.</i>		
Scope .....	1	1
Forms and records.....	2	1
<i>II. Description and data.</i>		
Purpose and use.....	3	2
Technical characteristics.....	4	2
Packaging data and components... ..	5	4
Description of Radio Receiver		
R-520/URR .....	6	5
Accessories and running spares....	7	5
Additional equipment.....	8	6
<b>CHAPTER 2. OPERATING INSTRUCTIONS</b>		
<i>Section I. Service upon receipt of equipment.</i>		
Siting .....	9	7
Uncrating, unpacking, and checking new equipment.....	10	7
Installation of receiver.....	11	10
Connections for power line operation .....	12	11
Connections for battery operation.	13	14
Service upon receipt of used or reconditioned equipment.....	14	16
<i>II. Controls.</i>		
General .....	15	17
Controls and their use.....	16	17
<i>III. Operation under usual conditions.</i>		
Standard procedure .....	17	17
Standard broadcast reception.....	18	19
Short-wave reception.....	19	21
Logging scale.....	20	22
Tone control.....	21	22
Headset .....	22	22
Stopping procedure.....	23	23

<i>Section IV.</i> Operation under unusual conditions.		
General .....	24	23
Operation in arctic climates.....	25	24
Operation in tropical climates.....	26	24
Operation in desert climates.....	27	25

**CHAPTER 3. ORGANIZATIONAL MAINTENANCE INSTRUCTIONS**

<i>Section I.</i> Organizational tools and equipment.		
Tools and materials used with		
Radio Receiver R-520/URR.....	28	26
Special tools supplied with Radio		
Receiver R-520/URR.....	29	26
<i>II.</i> Preventive maintenance services.		
Definition of preventive		
maintenance .....	30	27
General preventive maintenance		
techniques .....	31	27
Use of preventive maintenance		
forms .....	32	30
Performing exterior preventive		
maintenance .....	33	30
Performing interior preventive		
maintenance .....	34	31
<i>III.</i> Lubrication and weatherproofing.		
Lubrication instructions.....	35	32
Weatherproofing instructions.....	36	33
Cabinet finish .....	37	33
<i>IV.</i> Trouble shooting at organizational		
maintenance level.		
Scope .....	38	33
Visual inspection .....	39	34
Trouble shooting by using equip-		
ment performance checklist.....	40	34
Equipment performance checklist..	41	36

**CHAPTER 4. THEORY**

Block diagram.....	42	40
Tuning circuits.....	43	41
Broadcast antenna stage.....	44	42
Broadcast r-f stage.....	45	42

	<i>Paragraph</i>	<i>Page</i>
Broadcast converter stage.....	46	43
Continuous coverage bands.....	47	43
Spread bands.....	48	45
I-f amplifier.....	49	49
Detector-amplifier .....	50	49
Audio output.....	51	50
Tone control circuit.....	52	51
Avc system.....	53	51
Bias system.....	54	53
Power control circuit.....	55	55
External power source.....	56	55
Battery power source.....	57	56
Filament circuit.....	58	57
Plate and screen voltage distribution .....	59	59

## CHAPTER 5. FIELD MAINTENANCE INSTRUCTIONS

### *Section I.* Trouble shooting at field maintenance level.

Trouble-shooting procedure.....	60	61
Trouble-shooting data.....	61	63
Test equipment required for trouble shooting.....	62	63
General precautions.....	63	64
Chassis removal.....	64	65
Preliminary inspection.....	65	65
Voltage and resistance measurements .....	66	67
Operational test.....	67	67
Trouble-shooting charts.....	68	69
D-c resistance of transformers and coils .....	69	73
General signal substitution notes..	70	73
A-f signal substitution tests.....	71	77
I-f and converter signal substitution tests.....	72	78
R-f signal substitution tests.....	73	79
Antenna stage test.....	74	79
H-f oscillator test.....	75	79
Stage gain and sensitivity chart...	76	80

### *II.* Repairs.

Replacement of parts.....	77	81
---------------------------	----	----

	<i>Paragraph</i>	<i>Page</i>
<i>Section II.</i> Repairs (contd).		
Front cover hinge repair.....	78	82
Refinishing .....	79	84
<i>III.</i> Alinement procedures.		
Test equipment required for alinement .....	80	84
Calibration of signal generator....	81	85
Preparation for alinement.....	82	86
I-f alinement procedure.....	83	87
Broadcast band alinement.....	84	87
4-8 mc band alinement procedure..	85	89
2-4 mc band alinement procedure..	86	91
31 M band alinement procedure...	87	92
25 M band alinement procedure...	88	93
19 M band alinement procedure...	89	93
16 M band alinement procedure...	90	93
Chassis installation .....	91	95
Final adjustments.....	92	95
Alinement chart.....	93	96
<i>IV.</i> Final testing.		
General .....	94	101
Test equipment required for final testing .....	95	101
Operation of controls.....	96	101
Sensitivity .....	97	102
Selectivity .....	98	102
Image ratio check.....	99	102
Audio response .....	100	103
Avc and power output.....	101	104
<b>CHAPTER 6. SHIPMENT AND LIMITED STORAGE AND DEMOLITION TO PREVENT ENEMY USE</b>		
<i>Section I.</i> Shipment and limited storage.		
General .....	102	105
Repacking for shipment or limited storage .....	103	105
<i>II.</i> Demolition of materiel to prevent enemy use.		
General .....	104	106
Methods of destruction.....	105	106
APPENDIX I. References .....		107
APPENDIX II. Identification table of parts.....		110
INDEX .....		153

## LIST OF ILLUSTRATIONS

<i>Fig. No.</i>	<i>Title</i>	<i>Page</i>
1	Radio Receiver R-520/URR.....	xii
2	Packing and packaging of Radio Receiver R-520/URR .....	9
3	Spare parts and accessories.....	10
4	Radio Receiver R-520/URR, rear view, back cover open.....	11
5	Power supply adapter Z1.....	12
6	Power line cord adapters.....	13
7	Signal Corps battery pack connections.....	16
8	Radio Receiver R-520/URR, front panel.....	18
9	Extension cable connected to loop antenna.....	20
10	Antenna and ground terminals.....	21
11	Radio Receiver R-520/URR with headset connected .....	23
12	DA AGO Form 11-238.....	28
13	DA AGO Form 11-239.....	29
14	Lubrication points for Radio Receiver R-520/URR .....	32
15	Radio Receiver R-520/URR, block diagram.....	41
16	Broadcast band antenna, r-f amplifier, and converter circuits.....	44
17	4- to 8-mc band antenna, r-f amplifier, and converter circuits.....	46
18	16 M band antenna, r-f amplifier, and converter circuits.....	48

<i>Fig. No.</i>	<i>Title</i>	<i>Page</i>
19	I-f amplifier.....	49
20	Detector-amplifier and audio output stages.....	50
21	Tone control circuit.....	52
22	Radio Receiver R-520/URR, avc and bias system	54
23	Power supply circuit.....	58
24	Power supply adapter unit.....	57
25	Filament circuit.....	60
26	Radio Receiver R-520/URR, chassis removal....	66
27	Voltage and resistance diagram.....	68
28	Topview of chassis.....	74
29	Bottom view of chassis.....	75
30	Rear view of chassis.....	76
31	Band selector switch, rear view.....	82
32	Dial cord drive system.....	83
33	Front cover hinge assembly repair.....	84
34	Band selector switch shown in BC position.....	88
35	Band selector switch shown in 4-8 MC position	90
36	Band selector switch shown in 16 M position..	94
37	RMA test loop setup.....	100
38	Resistor color code.....	151
39	Capacitor color codes.....	152
40	Radio Receiver R-520/URR, schematic diagram.	152-A



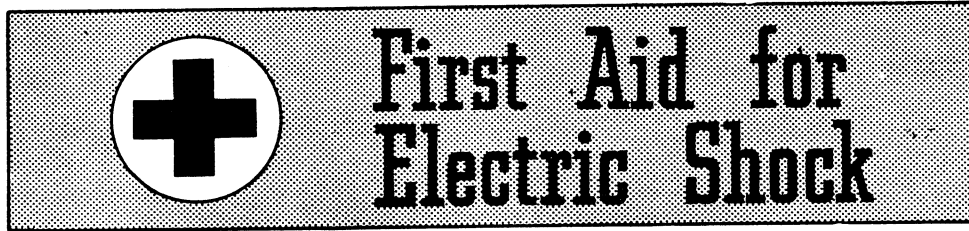

### RESCUE.

In case of electric shock, shut off the high voltage at once and ground the circuits. If the high voltage cannot be turned off without delay, free the victim from contact with the live conductor as promptly as possible. Avoid direct contact with either the live conductor or the victim's body. Use a dry board, dry clothing, or other nonconductor to free the victim. An ax may be used to cut the high-voltage\* wire. Use extreme caution to avoid the resulting electric flash.

### SYMPTOMS.

a. Breathing stops abruptly in electric shock if the current passes through the breathing center at the base of the brain. If the shock has not been too severe, the breath center recovers after a while and normal breathing is resumed, provided that a sufficient supply of air has been furnished meanwhile by artificial respiration.

b. The victim is usually very white or blue. The pulse is very weak or entirely absent and unconsciousness is complete. Burns are usually present. The victim's body may become rigid or stiff in a very few minutes. This condition is due to the action of electricity and is not to be considered rigor mortis. Artificial respiration must still be given, as several such cases are reported to have recovered. The ordinary and general tests for death should never be accepted.

### TREATMENT.

a. Start artificial respiration immediately. At the same time send for a medical officer, if assistance is available. Do not leave the victim unattended. Perform artificial respiration at the scene of the accident, unless the victim's or operator's life is endangered from such action. *In this case only*, remove the victim to another location, but no farther than is necessary for safety. If the new location is more than a few feet away, artificial respiration should be given while the victim is being moved. If the method of transportation prohibits the use of the Shaeffer prone pressure method, other methods of resuscitation may be used. Pressure may be exerted on the front of the victim's diaphragm, or the direct mouth-to-mouth method may be used. Artificial respiration, once started, must be continued, without loss of rhythm.

b. Lay the victim in a prone position, one arm extended directly overhead, and the other arm bent at the elbow so that the back of the hand supports the head. The face should be turned away from the bent elbow so that the nose and mouth are free for breathing.

c. Open the victim's mouth and remove any foreign bodies, such as false teeth, chewing gum, or tobacco. The mouth should remain open,

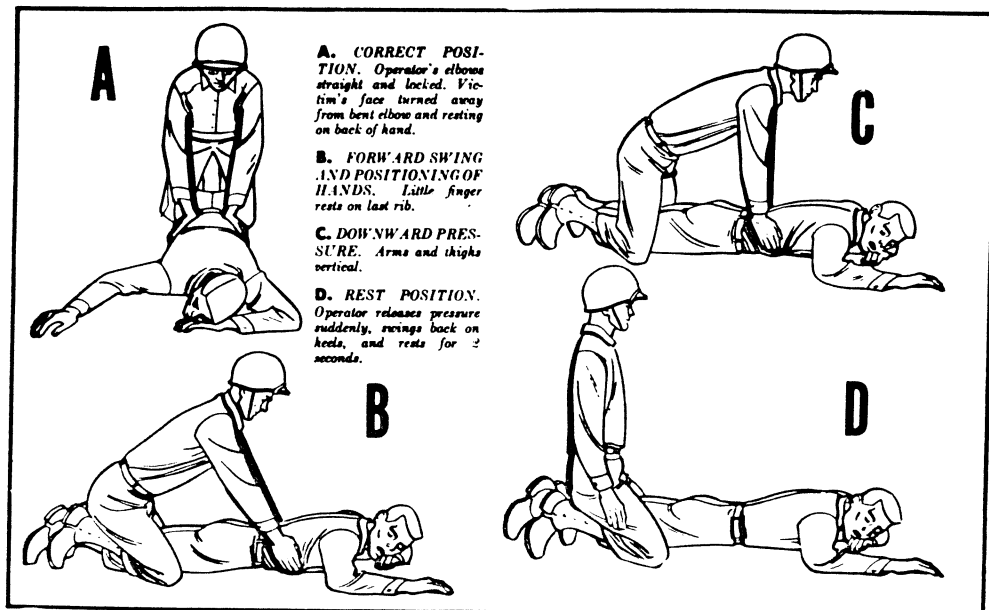

with the tongue extended. Do not permit the victim to draw his tongue back into his mouth or throat.

d. If an assistant is available during resuscitation, he should loosen any tight clothing to permit free circulation of blood and to prevent restriction of breathing. He should see that the victim is kept warm, by applying blankets or other covering, or by applying hot rocks or bricks wrapped in cloth or paper to prevent injury to the victim. The assistant should also be ever watchful to see that the victim does not swallow his tongue. He should continually wipe from the victim's mouth any frothy mucus or saliva that may collect and interfere with respiration.

e. The resuscitating operator should straddle the victim's thighs, or one leg, in such manner that:

- (1) the operator's arms and thighs will be vertical while applying pressure on the small of the victim's back;
- (2) the operator's fingers are in a natural position on the victim's back with the little finger lying on the last rib;
- (3) the heels of the hands rest on either side of the spine as far apart as convenient without allowing the hands to slip off the victim;
- (4) the operator's elbows are straight and locked.

f. The resuscitation procedure is as follows:

- (1) Exert downward pressure, not exceeding 60 pounds, for 1 second.
- (2) Swing back, suddenly releasing pressure, and sit on the heels.
- (3) After 2 seconds, swing forward again, positioning the hands exactly as before, and apply pressure for another second.

g. The forward swing, positioning of the hands, and the downward pressure should be accomplished in one continuous motion, which requires 1 second. The release and backward swing require 1 second. The addition of the 2-second rest makes a total of 4 seconds for a complete cycle. Until the operator is thoroughly familiar with the correct cadence

TL15338-B

of the cycle, he should count the seconds aloud, speaking distinctly and counting evenly in thousands. Example: one thousand and one, one thousand and two, etc.

**h.** Artificial respiration should be continued until the victim regains normal breathing or is pronounced dead by a medical officer. Since it may be necessary to continue resuscitation for several hours, relief operators should be used if available.

#### **RELIEVING OPERATOR.**

The relief operator kneels beside the operator and follows him through several complete cycles. When the relief operator is sure he has the correct rhythm, he places his hands on the operator's hands without applying pressure. This indicates that he is ready to take over. On the backward swing, the operator moves and the relief operator takes his position. The relieved operator follows through several complete cycles to be sure that the new operator has the correct rhythm. He remains alert to take over instantly if the new operator falters or hesitates on the cycle.

#### **STIMULANTS.**

**a.** If an inhalant stimulant is used, such as aromatic spirits of ammonia, the individual administering the stimulant should first test it himself to see how close he can hold the inhalant to his own nostril for comfortable breathing. Be sure that the inhalant is not held any closer to the victim's nostrils, and then for only 1 or 2 seconds every minute.

**b.** After the victim has regained consciousness, he may be given hot coffee, hot tea, or a glass of water containing  $\frac{1}{2}$  teaspoon of aromatic spirits of ammonia. *Do not give any liquids to an unconscious victim.*

#### **CAUTIONS.**

**a.** After the victim revives, keep him LYING QUIETLY. Any injury a person may have received may cause a condition of shock. Shock is present if the victim is pale and has a cold sweat, his pulse is weak and rapid, and his breathing is short and gasping.

**b.** Keep the victim lying flat on his back, with his head lower than the rest of his body and his hips elevated. Be sure that there is no tight clothing to restrict the free circulation of blood or hinder natural breathing. Keep him warm and quiet.

**c.** A resuscitated victim must be watched carefully as he may suddenly stop breathing. *Never leave a resuscitated person alone until it is CERTAIN that he is fully conscious and breathing normally.*

TL15338-C

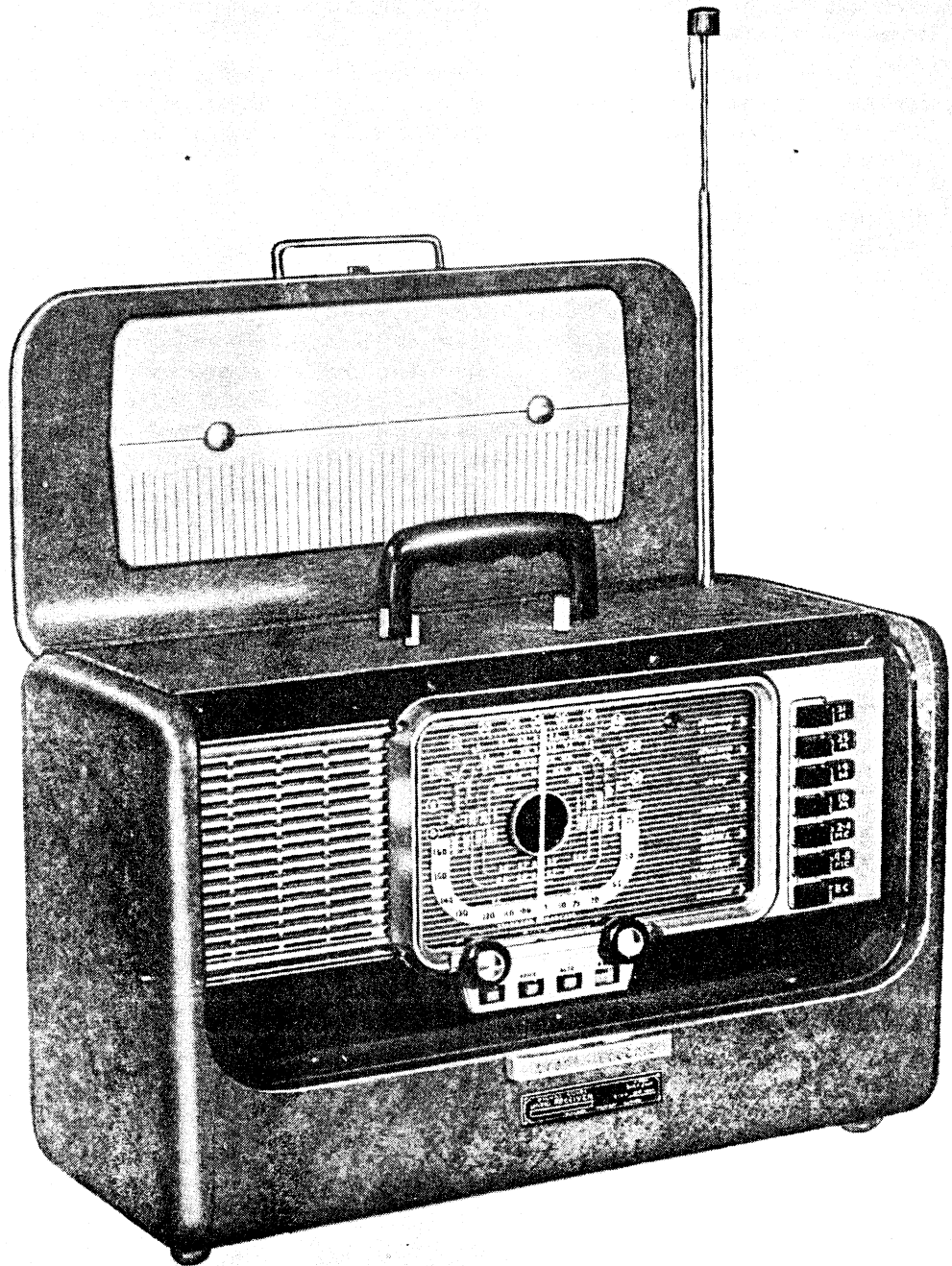

TM877-1

*Figure 1. Radio Receiver R-520/URR.*

*Note. This instruction book will be replaced by TM 11-877 which, when published, will be listed in SR 310-20-4.*

# CHAPTER 1

## INTRODUCTION

---

### Section I. GENERAL

#### 1. Scope

This instruction book contains a description, detailed theory of operation, and necessary instructions for the installation, operation, field maintenance, and repair of Radio Receiver R-520/URR. In addition, a chapter on the disassembly and repacking of the receiver for shipment or limited storage is included. There are two appendixes covering a list of references and an identification table of parts.

#### 2. Forms and Records

The following standard forms will be used for reporting unsatisfactory conditions of Army materiel and equipment.

- a.* DD Form 6, Report of Damaged or Improper Shipment, will be filled out and forwarded as prescribed in SR 745-45-5.
- b.* DA AGO Form 468, Unsatisfactory Equipment Report, will be filled out and forwarded to the Office of the Chief Signal Officer as prescribed in SR 700-45-5.
- c.* DA AGO Form 11-238, Operator First Echelon Maintenance Check List for Signal Corps Equipment (Radio Communication, Direction Finding, Carrier, Radar), will be prepared in accordance with instructions on the back of form (fig. 12).
- d.* DA AGO Form 11-239, Second and Third Echelon Maintenance Check List for Signal Corps Equipment (Radio Commu-

nication, Direction Finding, Carrier, Radar), will be prepared in accordance with instructions on the back of form (fig. 13).

e. Use other forms and records as authorized.

## Section II. DESCRIPTION AND DATA

### 3. Purpose and Use

a. Radio Receiver R-520/URR (fig. 1) is a portable superheterodyne radio receiver designed for troop information. It is contained in a luggage-type carrying case. The receiver will operate either a loudspeaker contained within the unit or a low-impedance headset connected externally.

b. Radio Receiver R-520/URR is designed to receive a-m (amplitude-modulated) signals covering frequency ranges from 550 kc (kilocycles) to 1600 kc, 2 mc (megacycles) to 4 mc, 4 mc to 8 mc, 9.4 mc to 9.8 mc, 11.6 mc to 12mc, 14.9 mc to 15.5 mc, and 17.5 mc to 18.1 mc. The receiver will operate from dry batteries or from an external a-c (alternating-current) or d-c (direct-current) source. The types of batteries and external power on which it will operate are listed in paragraph 4.

### 4. Technical Characteristics

Frequency range:

Broadcast band .....	540 kc to 1600 kc.
2-4 mc band.....	2 mc to 4 mc.
4-8 mc band.....	4 mc to 8 mc.
31 M (meter) band.....	9.4 mc to 9.8 mc.
25 M band.....	11.6 mc to 12 mc.
19 M band.....	14.9 mc to 15.5 mc.
16 M band.....	17.5 mc to 18.1 mc.
Receiver type .....	Superheterodyne
Type of signal which can be received.	A-m.
Intermediate frequency .....	455 kc.
Number of tubes.....	5.
Rectifier .....	Selenium.
Thermal resistor .....	Glass-inclosed.
Power input (battery) :	
A battery .....	9 volts at 67 ma.
B battery .....	90 volts at 17 ma.
Power input (power line) :	
117 volts ac.....	10 watts.
117 volts dc.....	7.5 watts.

230 volts ac..... 20 watts.  
230 volts dc..... 15 watts.

Antennas:

Loop ..... Fastened to inside of front cover. Removable to provide reception in steel buildings and vehicles. Used on the broadcast band.

Whip ..... 61 inches long (extended). Consists of eight telescoped sections. Switched into the antenna circuit when any one of the short-wave buttons are pressed.

Long wire ..... Antenna and ground terminals provided on rear of receiver for connecting external antenna (not supplied) and ground, to assure maximum signal pick-up in very weak signal areas.

Headset ..... Jack on rear of speaker accommodates Plug PL-55 for low-impedance headset connection (plug, cord, and headset not supplied).

Band selector ..... Seven band-selector buttons on the front panel provide a means of selecting the band covering the desired frequency range.

Tone control ..... Four tone-control buttons located below the dial scale on the front panel permit selection of 16 different tonal combinations.

Weight ..... 20 pounds, less batteries.

Battery .....	(not supplied)—Zenith type Z985. Single battery pack consisting of nine volts A and 90 volts B supply.
Signal Corps batteries.....	One 90-volt B Battery BA-423/U.
or	Three 3-volt A Batteries BA-407/U.
Signal Corps batteries.....	Three 90-volt B Batteries BA-270/U.
	Six 1.5-volt A Batteries BA-30/U.

*Note:* For Signal Corps battery combinations, see paragraph 13.

### 5. Packaging Data and Components (fig. 2)

a. Radio Receiver R-520/URR is shipped without batteries. When it is packaged for export or domestic shipment, two large bags and one small bag of silica-gel are placed in the battery compartment of each receiver. The receiver is placed in an inner carton and sealed. This carton is covered by a water-vaporproof bag which is placed in an outer carton and sealed with pressure-sensitive, water-resistant tape. Four of these outer cartons are packed in a wooden crate. The outside dimensions are listed in the following chart:

Item	Height (in.)	Width (in.)	Depth (in.)	Volume (cu. ft.)	Unit weight (lbs.)
Inner carton, 200-lb. test Kraft corrugated	14 ¼	19 ¼	10 ⅞	1.6	26
Outer carton, corrugated	15 ⅝	20	10 ½	1.9	29 ½
Wooden crate	33	22 ¼	12 ½	9.1	156

*Note.* Items may be packaged in a manner different from that shown, depending on the supply channel.

b. The following list indicates the contents of each wooden crate. See the packing list attached to each one for exact contents.

Crate dimensions (in.)	Contents	Notes
33 x 22 ¼ x 21 ½	Four packaged cartons, each containing one receiver .	Receivers shipped without batteries.  Spare parts and accessories are contained within the receiver.



c. Radio Receiver R-520/URR is the only component of the radio set. The receiver measures 12 inches high by 8 inches deep by  $19\frac{3}{8}$  inches long. It weighs 20 pounds, less batteries.

## **6. Description of Radio Receiver R-520/URR**

a. Radio Receiver R-520/URR (fig. 1) is a five-tube (plus selenium rectifier and glass-enclosed thermal resistor), portable, superheterodyne radio receiver designed to receive a-m signals on broadcast and short-wave bands. The front panel (fig. 8) contains all the controls required for the operation of the receiver. These include the volume control and on-off switch, tone control switch assembly, tuning control, and seven band selector buttons which permit any one of seven bands to be selected. When a push button is depressed, it catches and is held until another push button is partially depressed, at which time the first push button releases and the selector mechanism is disengaged. The broadcast range (540 to 1,600 kc) is covered by one band. There are two continuous coverage bands; one covers 2 to 4 mc and the other covers 4 to 8 mc. Four spread bands cover the frequencies from 17.5 mc to 18.1 mc; from 14.9 to 15.5 mc; from 11.6 to 12 mc; and from 9.4 to 9.8 mc. The receiver uses directly heated filament-type tubes and will operate on dry batteries (9 volts A and 90 volts B), 117 volts ac-dc, 220 volts ac or 220 volts dc. External antenna and ground terminals are provided for connecting an external antenna and ground in extremely weak signal areas. The external antenna is effective on all bands.

b. The receiver is built into a luggage-type carrying case, complete with handle. A loop antenna for broadcast reception is fastened to the inside of the front cover. The loop antenna can be removed and connected by an antenna extension cable to provide reception in steel buildings and vehicles. For short-wave reception, the receiver has a telescopic whip antenna that retracts into the cabinet. The rear cover is hinged for access to spares, accessories, batteries, tubes, headset jack, power adapter switch, and antenna connections. A latch near the top edge of the door holds the rear cover in the closed position.

c. The chassis is removable from the carrying case for repair and maintenance. See paragraph 64 for chassis removal instructions.

## **7. Accessories and Running Spares**

a. Included inside the cabinet of Radio Receiver R-520/-

URR are the loop antenna extension cable and suction cups, four power cord adapter plugs, the battery cable assemblies (contained in a bag), a nylon alinement wrench, and an instruction book.

b. Running spares are provided for all normally expendable items such as tubes, pilot lamps, fuses, and the glass-inclosed thermal resistor. Following is a list of running spares:

5 fuses, 3/16 ampere, Littelfuse type 3AG.

1 neon pilot bulb, GE type NE 51.

2 tubes 1U4.

1 tube 1L6.

1 tube 1U5.

1 tube 3V4.

1 glass-inclosed thermal resistor.

## 8. Additional Equipment

The following material is *not* supplied as part of Radio Receiver R-520/URR, but is required for certain operating conditions. 35-foot length antenna wire; low-impedance headset; and Headset Plug PL-55.

*Caution:* Do not make connections to antenna and ground terminals while the set is connected to the power line (fig. 10).

a. Two terminals are provided at the left rear of the chassis marked A and G for external antenna and ground connections. These are for use in areas of extremely low signal strength. If an external antenna and ground are connected to these terminals, signals previously impossible to obtain may be received in many cases (par. 18).

b. Under certain conditions, it may be advantageous to use a headset with a Plug PL-55 connected. The speaker is disconnected automatically when the plug is inserted into jack J3, located on the rear of the speaker (par. 51).

# CHAPTER 2

## OPERATING INSTRUCTIONS

---

### Section I. SERVICE UPON RECEIPT OF EQUIPMENT

#### 9. Siting

*a.* EXTERNAL REQUIREMENTS. The best location for radio equipment depends on local conditions such as the type of housing available and the terrain. Radio Receiver R-520/URR will have a greater receiving range if the unit is high and clear of hills, buildings, cliffs, densely wooded areas, and other obstructions. Depressions, valleys, and other low places are poor locations for radio reception because the surrounding high terrain absorbs r-f (radio-frequency) energy. Weak or otherwise undesirable signals may be expected if the set is operated under or close to steel buildings, underpasses, power lines, hospitals, or power units. If possible, choose a location on a hilltop or elevation. Normally, reception over water is better than over land.

*b.* INTERIOR REQUIREMENTS. If possible, keep the receiver away from sources of electrical interference or mechanical vibrations. Take precautions to prevent conditions of extreme temperatures or excessive moisture. In a permanent installation, locate the receiver to provide easy access to the front panel, leaving enough clearance for ventilation and space above the unit to extend the whip antenna for short-wave reception. For operation from external power, the receiver must be located within 6 feet of the power source outlet unless an extension power cable is available.

#### 10. Uncrating, Unpacking, and Checking New Equipment

*Note.* For used or reconditioned equipment, refer to paragraph 14.

*a.* GENERAL. Equipment may be shipped in oversea pack-

ing cases or in domestic packing cases and, sometimes, in its own carrying case. When new equipment is received, select a location where the equipment may be unpacked without exposure to the elements and which is convenient to the permanent or semipermanent installation of the equipment. The instructions in subparagraph *e* below apply to equipment in domestic packing cases. Check to see that all carrying cases are present and that the equipment is undamaged. No special unpacking and uncrating procedures are necessary for equipment shipped in carrying cases.

*Caution:* Be careful when uncrating, unpacking, and handling the equipment; it becomes damaged easily. If it is damaged or exposed, a complete overhaul might be required or the equipment might be rendered useless.

*b.* STEP-BY-STEP INSTRUCTIONS FOR UNCRATING AND UNPACKING EXPORT SHIPMENTS (fig. 2).

- (1) Place the packing case as near the operating position as convenient.
- (2) Cut and fold back the steel straps.
- (3) Remove the nails with a nail puller. Remove the top of the packing case. Do not attempt to pry off the sides; the equipment may become damaged.
- (4) Remove the moistureproof barrier and any excelsior or corrugated paper covering the equipment inside the case.
- (5) Remove the equipment from its inner case and place it on the workbench or near its final location.
- (6) Inspect the equipment for possible damage incurred during shipment.

*c.* OPENING CARDBOARD CARTON AND WATERPROOF BARRIER. No special instructions are needed for opening the waterproof barrier and removing the equipment from the cardboard carton.

*d.* CHECKING. Check the contents against the packing slip.

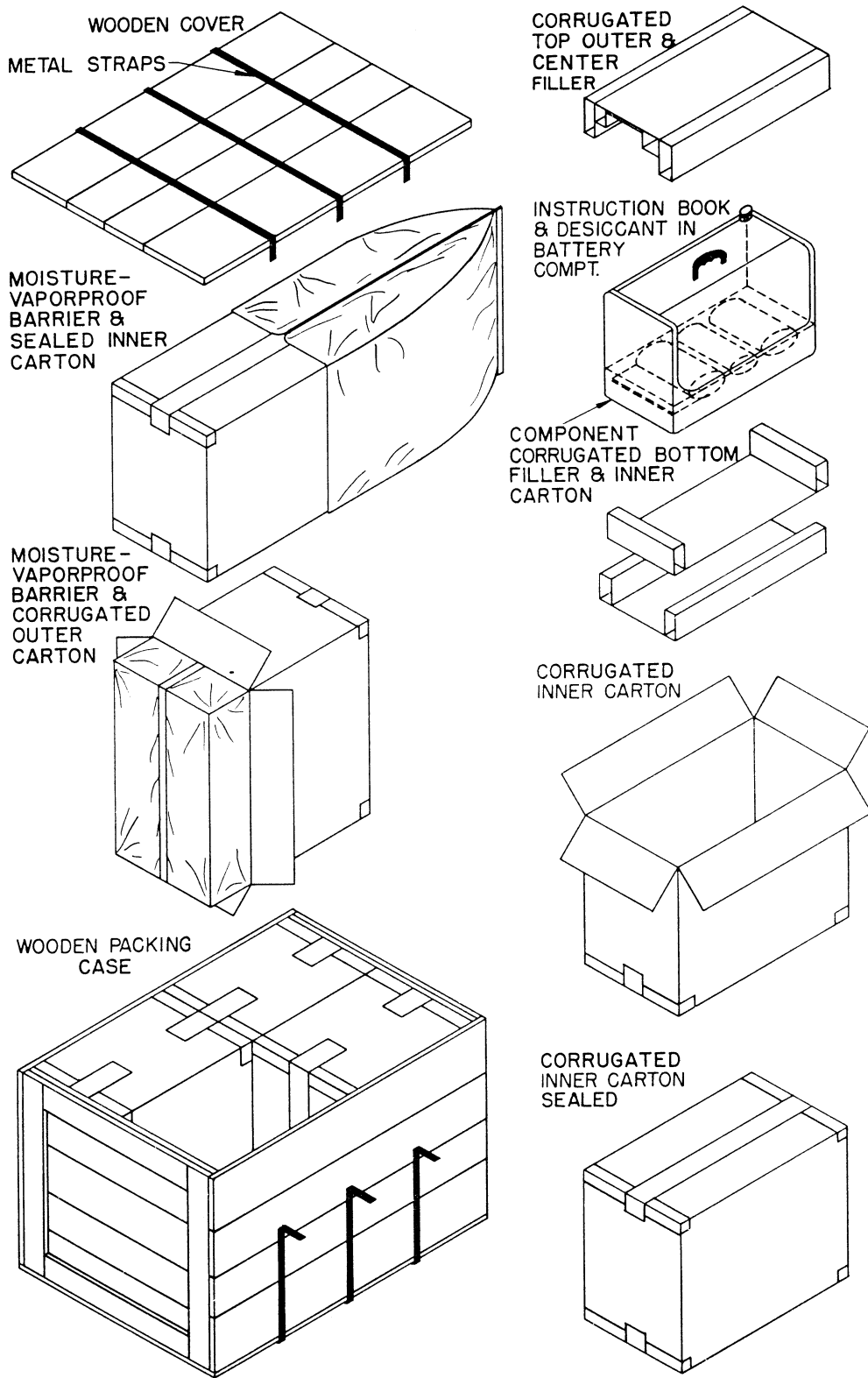

TM877-2

Figure 2. Packing and packaging of Radio Receiver R-520/URR.

e. UNPACKING DOMESTIC PACKING CASES. Radio equipment may be received in domestic packing cases. The instructions given in subparagraph *b* above apply also to unpacking domestic shipments. Open the cartons that protect the equipment or, if heavy wrapping paper has been used, remove it carefully and take out the components. Check the contents of the packing case against the packing slip.

*Note.* Save the original packing cases and containers for both export and domestic shipments. They can be used again when the equipment is re-packed for storage or shipment.

## 11. Installation of Receiver

Radio Receiver R-520/URR is shipped with the tubes, power supply adapter, fuse, and pilot lamp installed. The receiver is shipped without batteries and is ready to operate from a 220-volt, a-c power source. For operation from a 220-volt d-c or 110-volt ac-dc source see paragraph 12. Running spares and accessories are included on the inside of the receiver case (fig. 3).

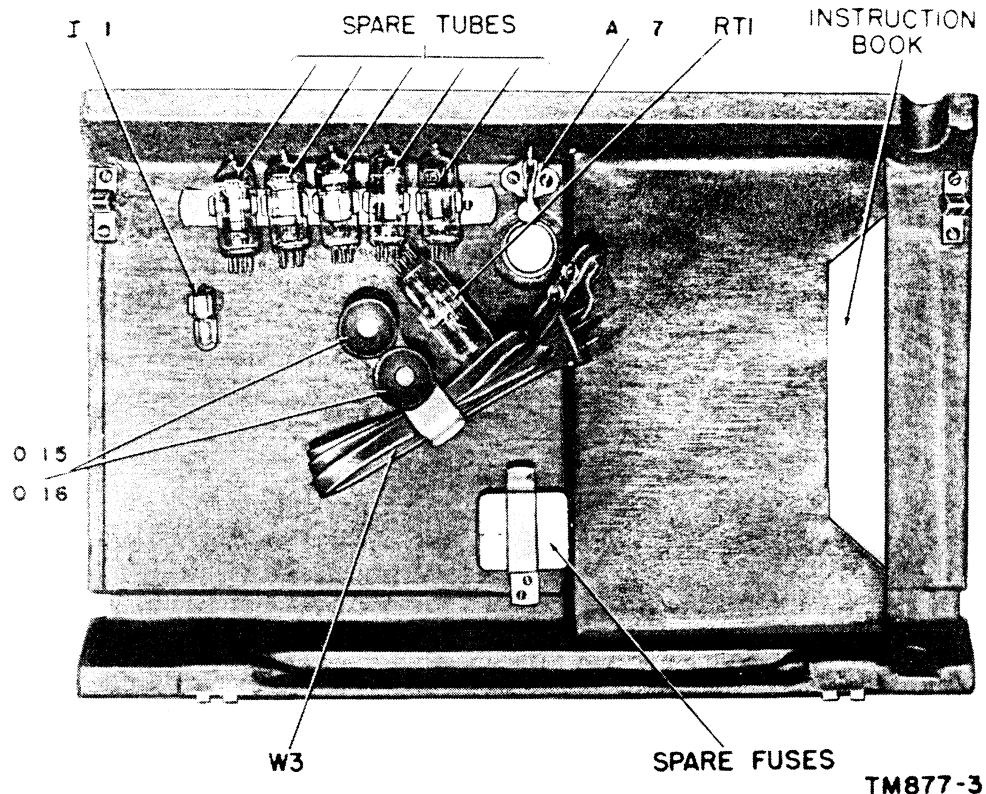

Figure 3. Spare parts and accessories.

## 12. Connections for Power Line Operation

Reach through the finger grip, located near the center of the rear door of the cabinet and release the latch, A7, by pushing upward (fig. 3). While holding the latch in the released position, open the door by pulling outward on the finger grip. Make certain that the power supply adaptor switch, located on power supply adapter Z1, is in the correct position to conform to the type power from which the set is to be operated (fig. 4). To move the power supply adapter switch, S5, loosen the knurled thumb bolt, H3, holding the switch positioning plate, N2 (fig. 5). Move the switch to the desired position and tighten the bolt.

a. The following chart lists the types of external power from which the receiver will operate and indicates power supply adapter switch position for each type.

Type of power	S5 Adapter switch position
105-130 volts ac	110 V. AC-DC.
105-130 volts dc	110 V. AC-DC.
205-230 volts dc	220 V. D.C.
205-230 volts ac	220 V. A.C.

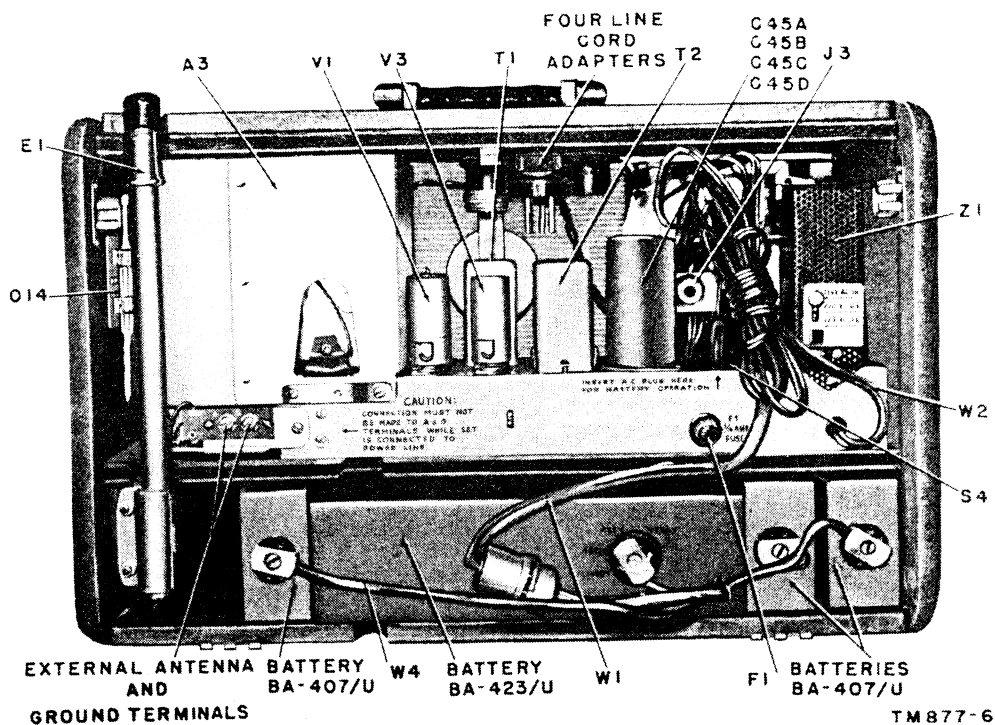
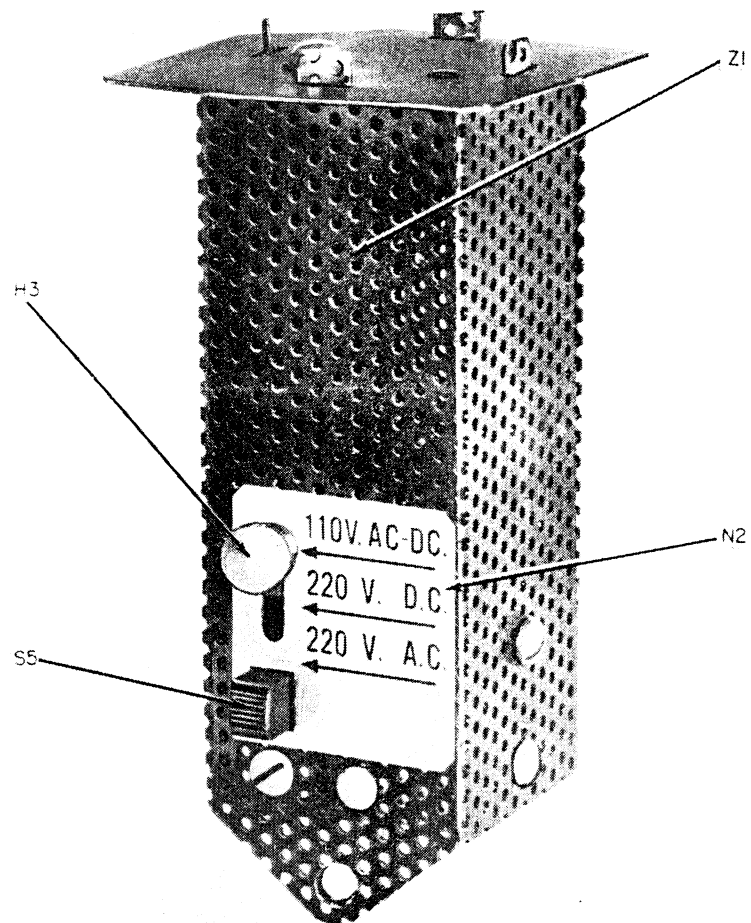

Figure 4. Radio Receiver R-520/URR, rear view, back cover open.

b. Remove the fuseholder cap at the rear of the receiver and examine fuse F1. Use only a 3/16-ampere type 3AG fuse.

*Warning:* Do not use a fuse rated at higher than 3/16 ampere because the receiver may become seriously damaged.



TM 877-4

Figure 5. Power Supply Adapter Z1.



c. Determine whether the power line cord plug will fit the power source outlet socket which can supply the correct voltage for the receiver. If the plug will not fit into the socket, select one of the four power line cord adapters located inside the case that will fit into the outlet socket (fig. 4). Figure 6 shows the power line cord adapters in detail. Plug the power line cord into the adapter before making connection to the power source outlet.

d. On direct current, the receiver will operate with the plug in one position only. If the receiver fails to operate after having been turned on, reverse the plug. On alternating current, it may be necessary to reverse the plug for minimum hum or noise.

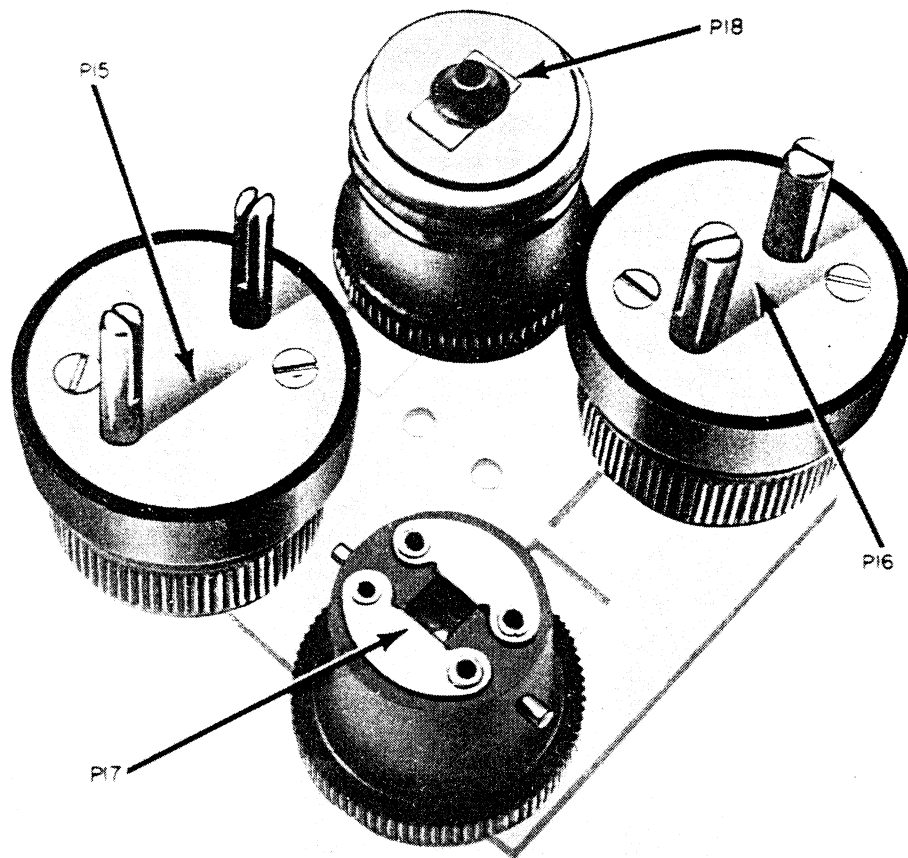

TM877-5

Figure 6. Power line cord adapters.

### 13. Connections for Battery Operation

Radio Receiver R-520/URR is designed to operate from a single self-contained battery pack (Zenith Z985, not supplied), or from one of several combinations of commonly available Signal Corps batteries. Several combinations of Signal Corps batteries permit operation with the batteries self-contained, while other combinations permit operation with the batteries located outside the case.

a. If available, place a Zenith battery pack Z985 in the battery compartment located below the receiver chassis and insert the plug of battery cable W1 into the receptacle on the battery. Insert the plug of line cord W2 into battery switch socket S4, on the top rear of the chassis. Stow excess cord as shown in figure 4.

b. The red harness, W4 (contained in the cloth bag inside the battery compartment) can be used with the Signal Corps battery complement shown in figure 4. One 90-volt B Battery BA-423/U and three 3-volt A Batteries BA-407/U are used. Insert the harness between the receiver battery cable W1 and the four Signal Corps batteries. In addition, the red harness, W4, will accommodate the following listed *emergency* battery complements within the battery compartment of the set.

Three batteries	One battery
BA-407/U	BA-419/U
BA-407/U	BA-416/U
BA-407/U	BA-415/U
BA-406/U	BA-423/U
BA-406/U	BA-419/U
BA-406/U	BA-416/U
BA-406/U	BA-415/U
BA-408/U	BA-415/U
BA-409/U	BA-415/U

c. The following battery combinations permit operation of the receiver in conjunction with the red harness, W4, with the batteries located outside the case:

Three batteries	One battery
BA-406/U	BA-420/U
BA-406/U	BA-424/U
BA-407/U	BA-420/U
BA-407/U	BA-423/U
BA-408/U	BA-416/U
BA-408/U	BA-419/U

Three batteries	One battery
BA-408/U	BA-420/U
BA-408/U	BA-423/U
BA-408/U	BA-424/U
BA-409/U	BA-416/U
BA-409/U	BA-419/U
BA-409/U	BA-420/U
BA-409/U	BA-423/U
BA-409/U	BA-424/U
BA-410/U	BA-415/U
BA-410/U	BA-416/U
BA-410/U	BA-419/U
BA-410/U	BA-420/U
BA-410/U	BA-423/U
BA-410/U	BA-424/U
BA-411/U	BA-415/U
BA-411/U	BA-416/U
BA-411/U	BA-419/U
BA-411/U	BA-420/U
BA-411/U	BA-423/U
BA-411/U	BA-424/U
BA-412/U	BA-415/U
BA-412/U	BA-416/U
BA-412/U	BA-419/U
BA-412/U	BA-420/U
BA-412/U	BA-423/U
BA-412/U	BA-424/U

d. Figure 7 shows the batteries that are connected by the yellow harness, W5, in the general position they occupy within the receiver battery compartment. This harness is connected permanently to battery case, E23, which is supplied with the set. It is located at the front end of the battery compartment and permits operation with the Signal Corps batteries contained within the receiver case. To insert six A Batteries BA-30/U into battery case E23, follow the directions given on the decal next to the removable end cover E24: To remove batteries press down with palm of hand and turn clockwise. Place the three B Batteries BA-270/U, into position in the battery compartment and connect cable W5 to them. Insert plug P10 into the receptacle of receiver battery cable W1.

e. With the black harness, W6, any external battery source can be used which has a 9-volt dc A supply and a 90-volt dc B supply. The four connecting leads are tagged, showing the voltages required (fig. 7).

*Caution:* Be sure to connect the A battery first, to avoid the

possibility of accidentally placing the B battery across the tube filaments and causing a burnout.

*Note.* Insert the battery cables that are not being used in the cloth bag and place the bag in the battery compartment.

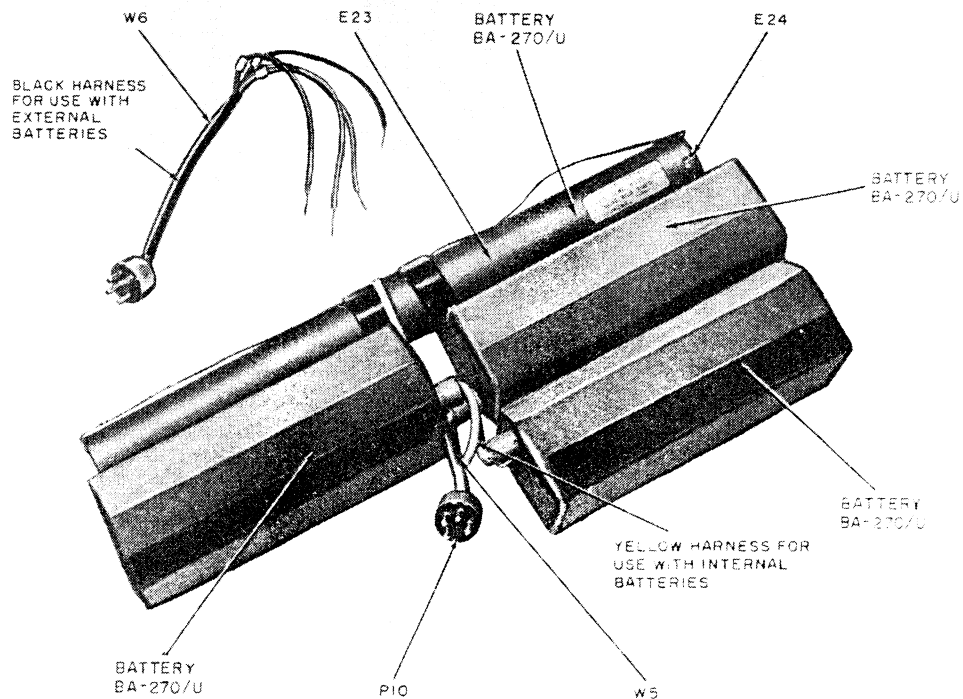

*Figure 7. Signal Corps battery pack connections.*

#### 14. Service Upon Receipt of Used or Reconditioned Equipment

*a.* Follow the instructions in paragraph 10 for uncrating, unpacking, and checking the equipment.

*b.* Check the used or reconditioned equipment for tags or other indications pertaining to changes in the wiring of the equipment. If any changes in wiring have been made, note the change in this instruction book along with the serial and order numbers of the modified equipment, preferably on the schematic diagram.

*c.* Check the operating controls for ease of rotation. If lubrication is required, refer to the lubrication instructions (ch. 3, sect. III).

*d.* Perform the installation and connection procedures given in paragraphs 11, 12, and 13.

## Section II. CONTROLS

### 15. General

Haphazard operation or improper setting of the controls can cause damage to electronic equipment. For this reason, it is important to know the function of every control. The actual operation of the equipment is discussed in the next section of this manual.

### 16. Controls and Their Uses (fig. 8)

Control	Function
On-off switch.	Turns receiver on and off.
Volume control.	Varies volume of audio output.
Band selector buttons.	Selects the band covering the desired frequency.
Tuning control.	Selects desired frequency by means of a dial mechanism and ganged tuning capacitor.
Switch assembly tone control.	Adjusts tone of the receiver to listener's individual preference by means of the four tone buttons below the dial. The combination of these four buttons in either of their two positions offers 16 possible tone combinations.

## Section. III. OPERATION UNDER USUAL CONDITIONS

### 17. Starting Procedure

*Note.* If, during the starting procedure, an abnormal result is obtained, refer to paragraph 41, equipment performance checklist.

*a.* Prepare the receiver for operation from the power source from which the set is to be operated (pars. 12 and 13).

*b.* Turn the volume control on-off switch knob clockwise until it clicks and the neon pilot light glows (fig. 8). Continue to turn the knob clockwise until the desired volume is obtained. When tuning for very weak signals, it may be necessary to turn the volume control to the maximum clockwise position.

*c.* Choose the band of operation and press the band selector button that covers the desired frequency (par. 4). The color of the letters and numerals on each band selector button is the same color as the corresponding scale on the dial.

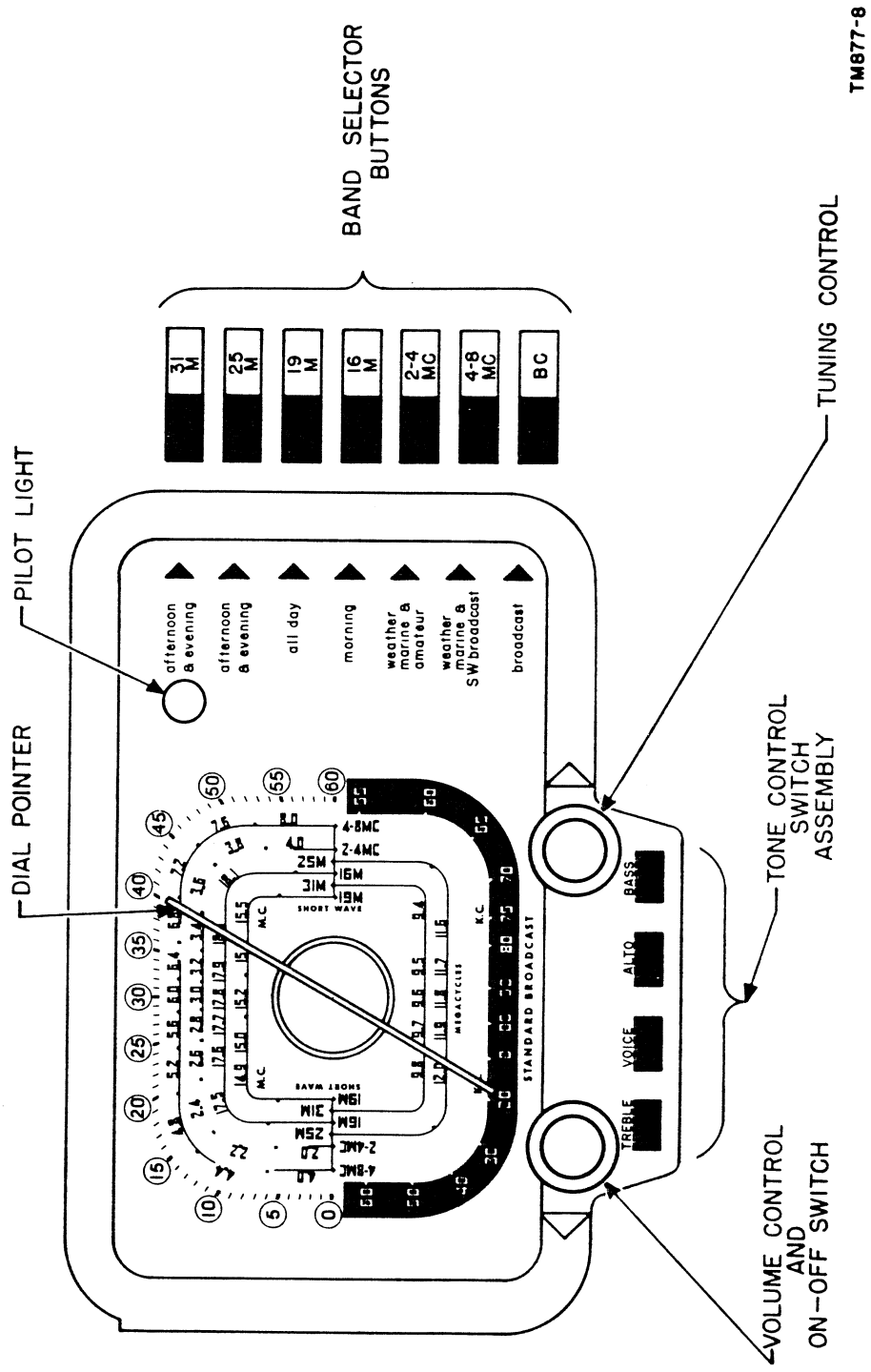

TM877-8

Figure 8. Radio Receiver R-520/URR, front panel.

## 18. Standard Broadcast Reception

The broadcast band portion of the dial scale is the buff-colored section indicated by the lower half of the pointer. This section is calibrated in kilocycles with the last zero deleted for convenience (fig. 8).

### a. NORMAL CONDITIONS.

- (1) Press the buff-colored band selector switch button marked BC.
- (2) Tune with the tuning control knob (fig. 8). Turn the knob very slowly for the center of the signal.
- (3) After a station has been tuned in, readjust the volume control to the desired volume.
- (4) Adjust the tone control buttons for the desired tone.

### b. STEEL STRUCTURES AND VEHICLES (fig. 9).

- (1) Remove the knurled brass nuts which hold loop antenna E2 in position on the inside of the front cover. Remove the antenna and replace the knurled nuts to prevent their loss.

*Caution:* Do not make connections to antenna and ground terminals while the set is connected to the power line.

- (2) Open the rear door of the cabinet and remove loop extension cable W3, and suction cups 0 15 and 0 16.
- (3) Remove plug P1 from the loop antenna socket (fig. 10). Insert the three-pronged plug, P8, on one end of loop extension cable W3 in receptacle J1 (fig. 28). Snap the other end of cable W3 on the loop antenna and snap the suction cups on the two remaining loop antenna snap fasteners.
- (4) Moisten the suction cups and apply the loop antenna to a corner of a window.

- (5) Continue with the same procedure for operating the receiver as outlined in paragraphs 17 and 18a.
- (6) Experiment for best reception and minimum noise by placing the loop antenna on various positions on the window.

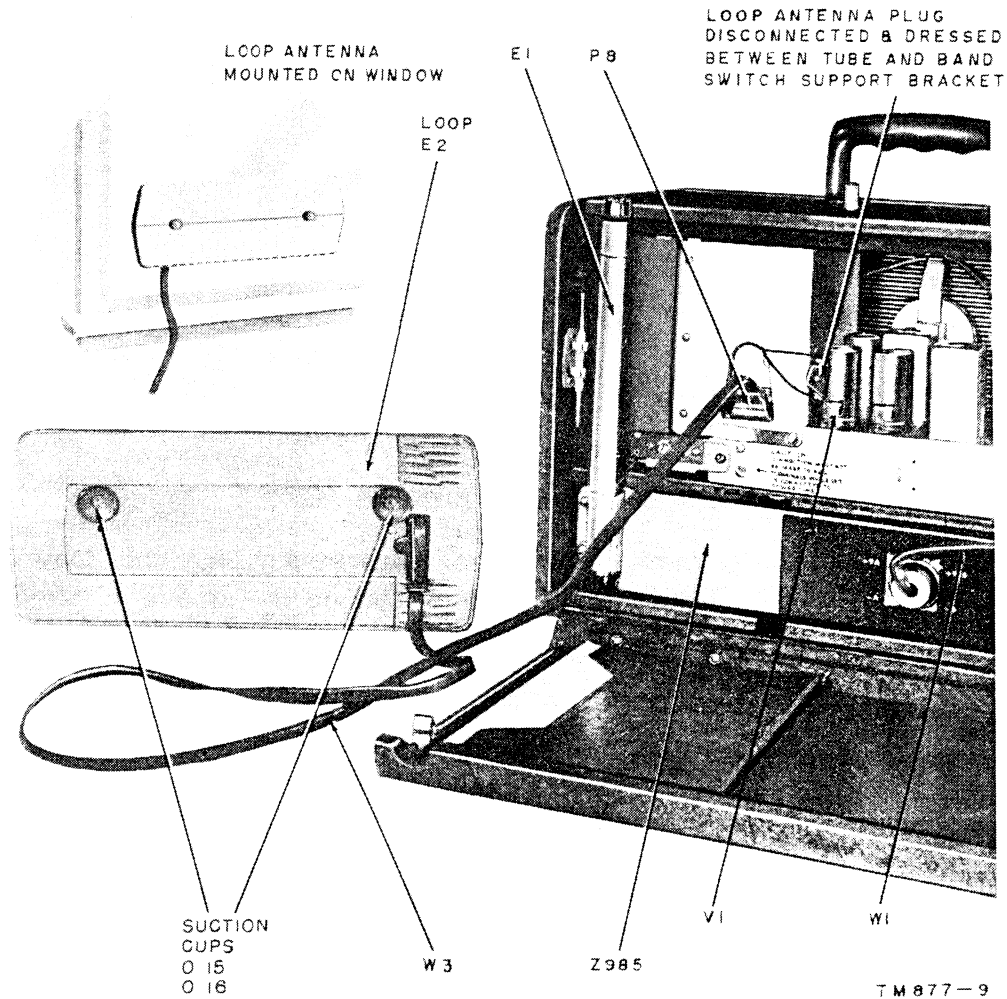

Figure 9. Extension cable connected to loop antenna.

c. ANTENNA AND GROUND (fig. 10).

Two terminals are provided at the left rear of the chassis marked A and G for external antenna and ground connection. These are for use in areas of extremely low signal strength. By connecting an external antenna and ground to these terminals, signals previously impossible to obtain are received in many cases. Ordinary field wire such as Wire WD-1/TT or W-110-B may be used. Erect



an external antenna at least 35 feet in length and as high as possible above ground and surrounding terrain. Bring down the insulated lead-in wire and connect it to the A terminal. Under some conditions, it may be necessary to connect a good ground to the G terminal. The external antenna and ground are automatically connected to the proper standard or short-wave circuit when the operator presses the band selector buttons.

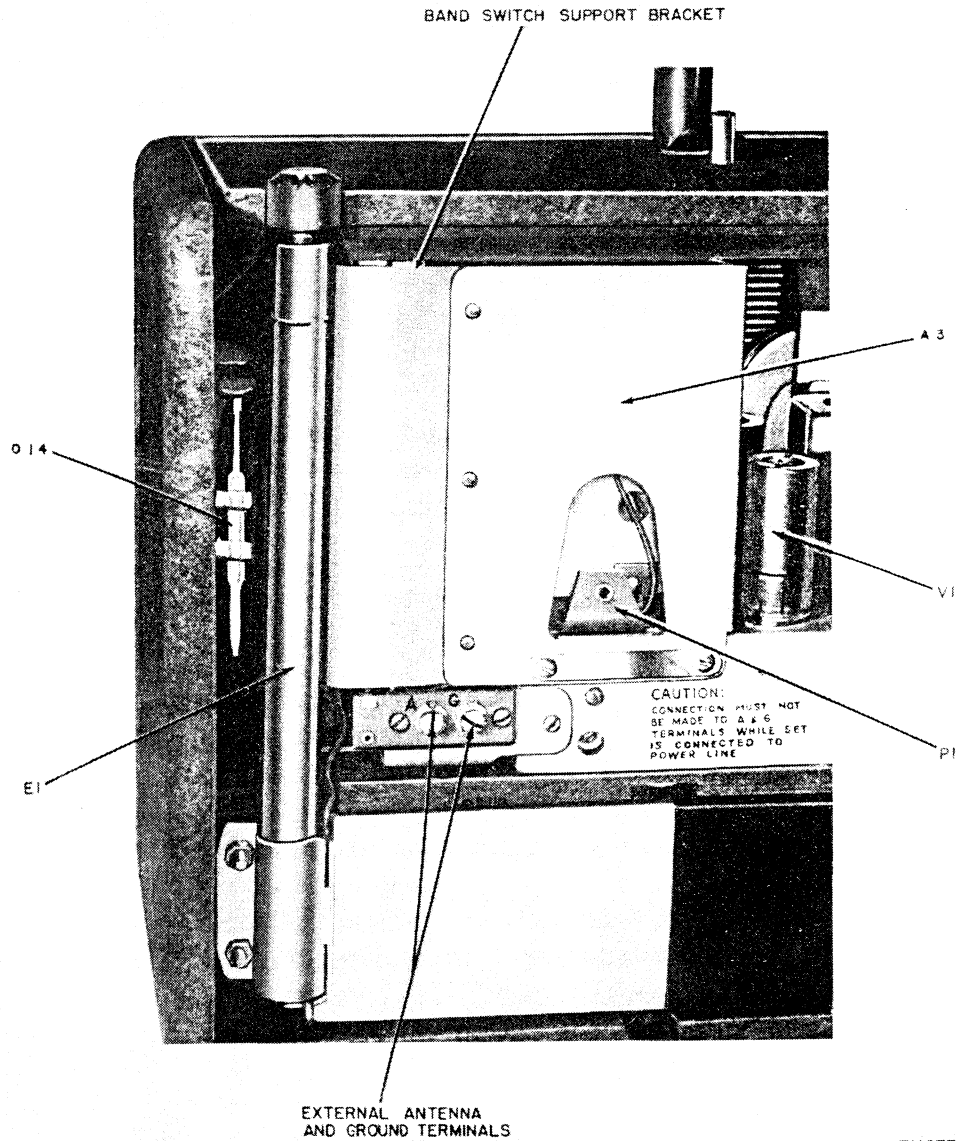

TM877-10

Figure 10. Antenna and ground terminals.

### 19. Short-wave Reception

The six short-wave bands are spread and calibrated on the dial in megacycles. Four bands are located on the upper half of the dial

and two on the lower half. Read with the upper half or lower half of the pointer, depending on the location of the scale in use. For short-wave operation, proceed as follows:

- a. Raise the front cover to an upright position.
- b. Turn the button on top of the telescopic whip antenna E2 until it snaps up. Extend the antenna to its full length.
- c. Press the desired short-wave band selector button.
- d. Continue with the same procedure for operating the receiver as outlined in paragraph 17.

#### **20. Logging Scale (fig. 8)**

A logging scale is provided in the upper edge of the dial face to assure ease and accuracy in logging and relocating short-wave stations.

*Example:* A station heard at 6.9 mc would be logged at 6.8 on the tuning band, plus the number of divisions occurring on the logging scale, which, in this case, would be 40. Therefore, the station would be logged as 6.8 + 40.

#### **21. Tone Control (fig. 8)**

a. The tone of Radio Receiver R-520/URR may be regulated to the preference of the listener by means of the four button tone switches below the dial. The combination of these four buttons in either of their two positions offers 16 possible tonal combinations. The portion of the tonal range is shown above each button.

b. For normal response, all tone control buttons are set to the right. To cut the low-frequency response, set the BASS button to the left and ALTO, VOICE and TREBLE buttons to the right. To lower the high frequency response, set the VOICE and/or TREBLE buttons to the left and the BASS and ALTO buttons to the right. Various combinations of tone control button settings will result in frequency responses suited to different conditions.

#### **22. Headset (fig. 11)**

Under certain conditions it may be advantageous to use a headset. To use the headset, connect a Plug PL-55 to the headset leads, open

the back cover of the case and insert the plug into jack J3, located on the rear of the speaker. The speaker is disconnected automatically when the plug is inserted. Best results are achieved with the use of a low impedance headset; however, an exact impedance match is not necessary.

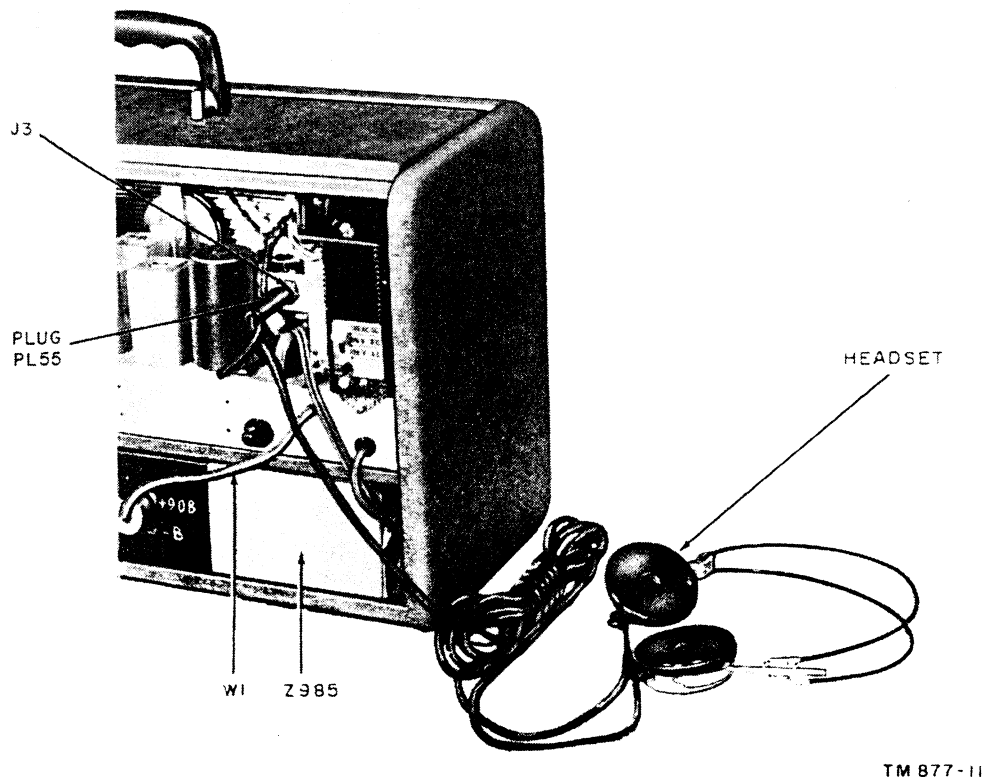

Figure 11. Radio Receiver R-520/URR with headset connected.

### 23. Stopping Procedure

When the set is not in use, make certain the power is OFF by turning the left control knob fully counterclockwise until a "click" is heard and the neon pilot light is out. Rotate the tuning control knob counterclockwise until the dial pointer is at the low-frequency end of the tuning range.

## Section IV. OPERATION UNDER UNUSUAL CONDITIONS

### 24. General

The operation of Radio Receiver R-520/URR may be difficult in regions of extreme cold, heat, humidity, sand, mud, snow, etc. In

the following paragraphs instructions are given on procedures for minimizing the effect of these unusual operating conditions.

## **25. Operation in Arctic Climates**

Subzero temperatures and climatic conditions associated with cold weather may affect the efficient operation of the equipment. Instructions and precautions for operation under such adverse conditions follow:

*a.* Handle the equipment carefully.

*b.* Keep the equipment warm and dry. If the set is not in a heated inclosure, construct an insulated box for the set.

*c.* Wear a knitted woolen cap over the headset when operating in the open air with a headset that does not have rubber earpieces. Frequently, when a headset without rubber earpieces is worn, the edges of the ears may freeze without the operator being conscious of this condition. Never flex rubber earcaps, since this action may render them useless. If water gets into the receiver portion of the headset, or if moisture condenses within them, it may freeze and impede the action of the diaphragms. When this happens, remove the bakelite cap and remove the ice and moisture.

*d.* When equipment which has been exposed to the cold is brought into a warm room, it will sweat and will continue to do so until it reaches room temperature. When the equipment has reached room temperature, dry it thoroughly. This condition also arises when equipment warms up during the day after exposure during a cold night.

*e.* Use any improvised means to protect dry batteries, since they will fail if not protected against the cold. Preheat the batteries. To prevent heat loss, place them in bags lined with kapok, spun glass fiber materials, animal skins, or woolen clothing.

## **26. Operation in Tropical Climates**

When operated in tropical climates, radio equipment may be installed in tents, huts, or, when necessary, in underground dugouts. When equipment is installed below ground and when it is set up in swampy areas, moisture conditions are more acute than normal in the tropics. Ventilation is usually very poor, and the high relative humidity causes condensation of moisture on the equipment when-

ever the temperature of the equipment becomes lower than the ambient air. To minimize this condition, place lighted electric bulbs under the equipment.

## **27. Operation in Desert Climates**

*a.* Conditions similar to those encountered in tropical climates often prevail in desert areas. Use the same measures to insure proper operation of the equipment.

*b.* The main problem which arises with equipment operation in desert areas is the large amount of sand or dirt and dust which enters the moving parts of radio equipment. The ideal preventive is to house the equipment in a dustproof shelter. Since such a building is seldom available and would require air conditioning, the next best precaution is to make the building in which the equipment is located as dustproof as possible with available materials. Hang wet sacking over the windows and doors, cover the inside walls with heavy paper, and secure the side walls of tents with sand to prevent their flapping in the wind.

*c.* Never tie power cords, signal cords, or other wire connections to the outside or inside of the tent. Desert areas are subject to sudden wind squalls which may jerk the connections loose or break the lines.

*d.* Be careful to keep the equipment as free from dust as possible. Make frequent preventive maintenance checks (ch. 3, sects. II and III). Pay particular attention to the lubricants.

# CHAPTER 3

## ORGANIZATIONAL MAINTENANCE INSTRUCTIONS

---

### Section I. ORGANIZATIONAL TOOLS AND EQUIPMENT

#### 28. Tools and Materials Used with Radio Receiver R-520/URR

Most of the repair or maintenance may be made with the tools found in Tool Equipment TE-41. The tools and equipment contained in Tool Equipment TE-41 are listed in the Department of the Army Supply Catalog SIG 6-TE-41. The only tool supplied with the receiver is nylon alinement wrench 0 14 (fig. 4).

- a.* TOOLS.
  - 1 Tool Equipment TE-41
  - 2 Alinement wrench 0 14
  
- b.* MATERIALS.
  - Orange stick
  - Carbon tetrachloride<sup>1</sup>
  - Cheesecloth, bleached, lint-free<sup>1</sup>
  - Paper, sand, flint #000<sup>1</sup>
  - Solvent, Dry Cleaning (SD) (Fed spec No. P-S-661a)

#### 29. Special Tools Supplied with Radio Receiver R-520/URR

Alinement wrench 0 14 is the only special tool supplied with the radio set. One end of the wrench has a hexagon-shaped shaft which is used for the alinement of the i-f (intermediate-frequency) cores.

---

<sup>1</sup>Part of Tool Equipment TE-41.

This design allows the wrench to slip through or engage the i-f transformer primary or secondary coil core so that alinement may be performed from the top of the chassis. The other end has a spade tip and is to be used for adjustment of the antenna, r-f and oscillator coil cores. *Do not use the alinement wrench as a screw driver to turn trimmer capacitors.*

## **Section II. PREVENTIVE MAINTENANCE SERVICES**

### **30. Definition of Preventive Maintenance**

Preventive maintenance is work performed on equipment (usually when the equipment is not in use) to keep it in good working order so that break-downs and needless interruptions in service will be kept to a minimum. Preventive maintenance differs from trouble shooting and repair, since its object is to prevent certain troubles from occurring. See AR 750-5.

### **31. General Preventive Maintenance Techniques**

*a.* Keep the interior of the set clean. Use a clean, dry, lint-free cloth or a dry brush for cleaning.

*b.* Inspect for faults which are just beginning to show, and make the necessary repairs. For example, locate and tighten loose mechanical parts, reconnect broken leads, tape frayed cables and wires, locate and replace parts which appear ready to fail (scorched resistors, leaking capacitors). Be sure that all pluck-out items (tubes, fuse, adapter) are seated firmly in their sockets.

*c.* Clean the band selector switch contacts with carbon tetrachloride only if absolutely necessary. Be careful not to get the carbon tetrachloride solution on the coils since this may deposit wax on the switch contacts and cause erratic operation.

*Caution:* Repeated contact of carbon tetrachloride with the skin or prolonged breathing of the fumes is dangerous. Make sure adequate ventilation is provided.

*Note.* Screws, bolts, and nuts should not be tightened carelessly. Fittings tightened beyond the pressure for which they are designed will be damaged or broken. Be careful of any screws which screw into a plastic or bakelite material, since the threads in this material are stripped easily. For further information on Preventive Maintenance Techniques, refer to TB SIG 178.

OPERATOR FIRST ECHELON MAINTENANCE CHECK LIST FOR SIGNAL CORPS EQUIPMENT RADIO COMMUNICATION, DIRECTION FINDING, CARRIER, RADAR										
INSTRUCTIONS: See other side										
EQUIPMENT NOMENCLATURE					EQUIPMENT SERIAL NO.					
LEGEND FOR MARKING CONDITIONS: ✓ Satisfactory; X Adjustment, repair or replacement required; ⊗ Defect corrected. NOTE: Strike out items not applicable.										
DAILY										
NO.	ITEM	CONDITION							NO.	ITEM
		S	M	T	W	T	F	S		
1	COMPLETENESS AND GENERAL CONDITION OF EQUIPMENT (receiver, transmitter, carrying cases, wire and cable, microphones, tubes, spare parts, technical manuals and accessories). <span style="float: right;">PAR 33 a</span>									
2	LOCATION AND INSTALLATION SUITABLE FOR NORMAL OPERATION. <span style="float: right;">PAR 33 b</span>									
3	CLEAN DIRT AND MOISTURE FROM ANTENNA, MICROPHONE, HEADSETS, CHESTSETS, KEYS, JACKS, PLUGS, TELEPHONES, CARRYING BAGS, COMPONENT PANELS. <span style="float: right;">PAR 33 c</span>									
4	INSPECT SEATING OF READILY ACCESSIBLE "PLUCK-OUT" ITEMS: TUBES, LAMPS, CRYSTALS, FUSES, CONNECTORS, VIBRATORS, PLUG-IN COILS AND RESISTORS. <span style="float: right;">PAR 33 d</span>									
5	INSPECT CONTROLS FOR BINDING, SCRAPING, EXCESSIVE LOOSENESS, WORN OR CHIPPED GEARS, MISALIGNMENT, POSITIVE ACTION. <span style="float: right;">PAR 33 e</span>									
6	CHECK FOR NORMAL OPERATION. <span style="float: right;">PAR 33 f</span>									
WEEKLY										
NO.	ITEM	COND.	NO.	ITEM	COND.					
7	CLEAN AND TIGHTEN EXTERIOR OF COMPONENTS AND CASES, RACK MOUNTS, SHOCK MOUNTS, ANTENNA MOUNTS, COAXIAL TRANSMISSION LINES, WAVE GUIDES, AND CABLE CONNECTIONS.		13	INSPECT STORAGE BATTERIES FOR DIRT, LOOSE TERMINALS, ELECTROLYTE LEVEL AND SPECIFIC GRAVITY, AND DAMAGED CASES.						
8	INSPECT CASES, MOUNTINGS, ANTENNAS, TOWERS, AND EXPOSED METAL SURFACES, FOR RUST, CORROSION, AND MOISTURE.		14	CLEAN AIR FILTERS, BRASS NAME PLATES, DIAL AND METER WINDOWS, JEWEL ASSEMBLIES. <span style="float: right;">PAR 33 j</span>						
9	INSPECT COND. CABLE, WIRE, AND SHOCK MOUNTS FOR CUTS, BREAKS, FRAYING, DETERIORATION, KINKS, AND STRAIN. <span style="float: right;">PAR 33 g</span>		15	INSPECT METERS FOR DAMAGED GLASS AND CASES.						
10	INSPECT ANTENNA FOR ECCENTRICITIES, CORROSION, LOOSE FIT, DAMAGED INSULATORS AND REFLECTORS. <span style="float: right;">PAR 33 h</span>		16	INSPECT SHELTERS AND COVERS FOR ADEQUACY OF WEATHER-PROOFING. <span style="float: right;">PAR 33 k</span>						
11	INSPECT CANVAS ITEMS, LEATHER, AND CABLING FOR MILDEW, TEARS, AND FRAYING.		17	CHECK ANTENNA GUY WIRES FOR LOOSENESS AND PROPER TENSION.						
12	INSPECT FOR LOOSENESS OF ACCESSIBLE ITEMS: SWITCHES, FIDERS, JACKS, CONNECTORS, ELECTRICAL TRANSFORMERS, POWER-STATS, RELAYS, SELSYNS, MOTORS, BLOWERS, CAPACITORS, GENERATORS, AND PILOT LIGHT ASSEMBLIES. <span style="float: right;">PAR 33 i</span>		18	CHECK TERMINAL BOX COVERS FOR CRACKS, LEAKS, DAMAGED GASKETS, DIRT AND GREASE.						
19	IF DEFICIENCIES NOTED ARE NOT CORRECTED DURING INSPECTION, INDICATE ACTION TAKEN FOR CORRECTION.									

DA AGO FORM 11-238  
1 MAY 51

REPLACES DA AGO FORM 439, 1 DEC 50, WHICH IS OBSOLETE.

TM 877-12

Figure 12. DA AGO Form 11-238.



SECOND AND THIRD ECHELON MAINTENANCE CHECK LIST FOR SIGNAL CORPS EQUIPMENT RADIO COMMUNICATION, DIRECTION FINDING, CARRIER, RADAR			
INSTRUCTIONS: See other side			
EQUIPMENT NOMENCLATURE		EQUIPMENT SERIAL NO.	
LEGEND FOR MARKING CONDITIONS: ✓ Satisfactory; X Adjustment, repair or replacement required; ⊕ Defect corrected. NOTE: Strike out items not applicable.			
NO.	ITEM	NO.	ITEM
1	COMPLETENESS AND GENERAL CONDITION OF EQUIPMENT (receiver, transmitter, carrying cases, wire and cable, microphone, tubes, spare parts, technical manuals and accessories). PAR 33 a	19	ELECTRON TUBES - INSPECT FOR LOOSE ENVELOPES, CAP CONNECTORS, CRACKED SOCKETS; INSUFFICIENT SOCKET SPRING TENSION; CLEAN DUST AND DIRT CAREFULLY; CHECK EMISSION OF RECEIVER TYPE TUBES. PAR 34 a
2	LOCATION AND INSTALLATION SUITABLE FOR NORMAL OPERATION. PAR 33 b	20	INSPECT FILM CUT-OUTS FOR LOOSE PARTS, DIRT, MISALIGNMENT AND CORROSION.
3	CLEAN DIRT AND MOISTURE FROM ANTENNA, MICROPHONE, HEADSETS, CHESTSETS, KEYS, JACKS, PLUGS, TELEPHONES, CARRYING BAGS, COMPONENT PANELS. PAR 33 c	21	INSPECT FIXED CAPACITORS FOR LEAKS, BULGES, AND DISCOLORATION. PAR 34 b
4	INSPECT SEATING OF READILY ACCESSIBLE "PLUCK-OUT" ITEMS: TUBES, LAMPS, CRYSTALS, FUSES, CONNECTORS, VIBRATORS, PLUG-IN COILS AND RESISTORS. PAR 33 d	22	INSPECT RELAY AND CIRCUIT BREAKER ASSEMBLIES FOR LOOSE MOUNTINGS; BURNED, PITTED, CORRODED CONTACTS; MISALIGNMENT OF CONTACTS AND SPRINGS; INSUFFICIENT SPRING TENSION; BINDING OF PLUNGERS AND HINGE PARTS.
5	INSPECT CONTROLS FOR BINDING, SCRAPING, EXCESSIVE LOOSENESS, WORN OR CHIPPED GEARS, MISALIGNMENT, POSITIVE ACTION. PAR 33 e	23	INSPECT VARIABLE CAPACITORS FOR DIRT, MOISTURE, MISALIGNMENT OF PLATES, AND LOOSE MOUNTINGS. PAR 34 c
6	CHECK FOR NORMAL OPERATION. PAR 33 f	24	INSPECT RESISTORS, BUSHINGS, AND INSULATORS, FOR CRACKS, CHIPPING, BLISTERING, DISCOLORATION AND MOISTURE. PAR 34 d
7	CLEAN AND TIGHTEN EXTERIOR OF COMPONENTS AND CASES, RACK MOUNTS, SHOCK MOUNTS, ANTENNA MOUNTS, COAXIAL TRANSMISSION LINES, WAVE GUIDES, AND CABLE CONNECTIONS.	25	INSPECT TERMINALS OF LARGE FIXED CAPACITORS AND RESISTORS FOR CORROSION, DIRT AND LOOSE CONTACTS.
8	INSPECT CASES, MOUNTINGS, ANTENNAS, TOWERS, AND EXPOSED METAL SURFACES, FOR RUST, CORROSION, AND MOISTURE.	26	CLEAN AND TIGHTEN SWITCHES, TERMINAL BLOCKS, BLOWERS, RELAY CASES, AND INTERIORS OF CHASSIS AND CABINETS NOT READILY ACCESSIBLE. PAR 34 e
9	INSPECT CORD, CABLE, WIRE, AND SHOCK MOUNTS FOR CUTS, BREAKS, FRAYING, DETERIORATION, KINKS, AND STRAIN. PAR 33 g	27	INSPECT TERMINAL BLOCKS FOR LOOSE CONNECTIONS, CRACKS AND BREAKS.
10	INSPECT ANTENNA FOR ECCENTRICITIES, CORROSION, LOOSE FIT, DAMAGED INSULATORS AND REFLECTORS. PAR 33 h	28	CHECK SETTINGS OF ADJUSTABLE RELAYS.
11	INSPECT CANVAS ITEMS, LEATHER, AND CABLING FOR MILDEW, TEARS, AND FRAYING.	29	LUBRICATE EQUIPMENT IN ACCORDANCE WITH APPLICABLE DEPARTMENT OF THE ARMY LUBRICATION ORDER. PAR 34 f
12	INSPECT FOR LOOSENESS OF ACCESSIBLE ITEMS: SWITCHES, KNOBS, JACKS, CONNECTORS, ELECTRICAL TRANSFORMERS, POWERSTATS, RELAYS, SELSYMS, MOTORS, BLOWERS, CAPACITORS, GENERATORS, AND PILOT LIGHT ASSEMBLIES. PAR 33 i	30	INSPECT GENERATORS, AMPLIDYNES, DYNAMOTORS, FOR BRUSH WEAR, SPRING TENSION, ARCING, AND FITTING OF COMMUTATOR.
13	INSPECT STORAGE BATTERIES FOR DIRT, LOOSE TERMINALS, ELECTROLYTE LEVEL AND SPECIFIC GRAVITY, AND DAMAGED CASES.	31	CLEAN AND TIGHTEN CONNECTIONS AND MOUNTINGS FOR TRANSFORMERS, CHOKES, POTENTIOMETERS, AND RHEOSTATS. PAR 34 g
14	CLEAN AIR FILTERS, BRASS NAME PLATES, DIAL AND METER WINDOWS, JEWEL ASSEMBLIES. PAR 33 j	32	INSPECT TRANSFORMERS, CHOKES, POTENTIOMETERS, AND RHEOSTATS FOR OVERHEATING AND OIL-LEAKAGE. PAR 34 h
15	INSPECT METERS FOR DAMAGED GLASS AND CASES.	33	BEFORE SHIPPING OR STORING - REMOVE BATTERIES. PAR 34 i
16	INSPECT SHELTERS AND COVERS FOR ADEQUACY OF WEATHERPROOFING. PAR 33 k	34	INSPECT CATHODE RAY TUBES FOR BURNT SCREEN SPOTS.
17	CHECK ANTENNA GUY WIRES FOR LOOSENESS AND PROPER TENSION.	35	INSPECT BATTERIES FOR SHORTS AND DEAD CELLS. PAR 34 j
18	CHECK TERMINAL BOX COVERS FOR CRACKS, LEAKS, DAMAGED GASKETS, DIRT AND GREASE.	36	INSPECT FOR LEAKING WATERPROOF GASKETS, WORN OR LOOSE PARTS.
		37	MOISTURE AND FUNGIPROOF. PAR 34 k
38	IF DEFICIENCIES NOTED ARE NOT CORRECTED DURING INSPECTION, INDICATE ACTION TAKEN FOR CORRECTION.		

DA AGO FORM 11-239  
1 MAY 51

REPLACES DA AGO FORM 439, 1 DEC 50, WHICH IS OBSOLETE.

16-44283-1

TM 877-13

Figure 13. DA AGO Form 11-239.

### **32. Use of Preventive Maintenance Forms (figs. 12 and 13)**

*a.* The decision as to which items on DA AGO Forms 11-238 and 11-239 are applicable to this equipment is a tactical decision to be made in the case of first echelon maintenance by the communications officer/chief or his designated representative, and in the case of second and third echelon maintenance, by the individual making the inspection. Instructions for the use of each form appear on the reverse side of the form.

*b.* Circled items in figures 12 and 13 are partially or totally applicable to Radio Receiver R-520/URR. References in the ITEM block refer to paragraphs in text which contain additional maintenance information.

### **33. Performing Exterior Preventive Maintenance**

*Caution:* Tighten screws, bolts, and nuts carefully. Fittings tightened beyond the pressure for which they are designed will be damaged or broken.

*a.* Check for completeness and satisfactory condition of the radio set. The components of the radio set are listed in paragraph 5 and are illustrated in figures 1, 3, and 4.

*b.* Check suitability of location and installation for normal operation (par. 9).

*c.* Remove dirt and moisture from antenna, headset, jack, plugs, and carrying case (fig. 4).

*d.* Inspect seating of readily accessible pluck-out items: tubes, pilot light, fuse F1, and the four adapter connectors (figs. 4, 5, 6, and 28).

*e.* Inspect tone control switches, tuning control, volume control, and band selector switches for binding, scraping, excessive looseness, misalignment, and positive action (fig. 8).

*f.* Check for normal operation (par. 41).

*g.* Inspect line cord, battery cables, and wire for cuts, breaks, fraying, deterioration, kinks, and strain (par. 13 and figs. 4 and 7).

*h.* Inspect loop and whip antennas for corrosion and loose fit (figs. 9, 10, and 33).

*i.* Inspect for looseness of accessible items; tone control switches, tuning and volume control knobs, band selector switches, jack J3, connectors, transformer T3, capacitor C45, and pilot light assembly (figs. 4, 8, 28, and 30).

*j.* Clean dial window and neon pilot light assembly (figs. 1 and 28).

*k.* Inspect shelters and covers for adequacy of weather-proofing (par. 9).

#### **34. Performing Interior Preventive Maintenance**

*Caution:* Disconnect all power before performing the following operations. Upon completion, reconnect power, and check for satisfactory operation.

*a.* Inspect electron tubes for loose envelopes, cracked sockets, bent pins, insufficient socket spring tension; remove dust and dirt carefully; check emission of tubes.

*b.* Inspect fixed capacitors C25 and C45 for leaks, bulges, and discoloration (figs. 29 and 30).

*c.* Inspect variable tuning capacitor C2 for dirt, moisture, misalignment of plates, and loose mountings (fig. 28).

*d.* Inspect resistors for cracks, chipping, blistering, discoloration, and moisture (fig. 29).

*e.* Clean and tighten switches and interiors of chassis and cabinets not readily accessible (par. 63).

*f.* Lubricate equipment in accordance with applicable Department of the Army lubrication order (par. 35, fig. 14).

*g.* Clean and tighten connections and mountings for loudspeaker LS1, transformer T3 and potentiometers (par. 63, figs. 28 and 29).

*h.* Inspect transformer T3 and potentiometers for overheating (figs. 28 and 29).

*i.* Before shipping or storing, remove batteries (par. 103).

*j.* Inspect batteries for shorts and dead cells. (If batteries are swelling or oozing, replace immediately. If neon pilot light

does not glow on battery operation, replace the B. battery pack as this indicates insufficient B+ voltage.)

k. Check for adequacy of moisture-fungiproofing (par. 36).

l. If deficiencies noted are not corrected during inspection, indicate what action was taken.

### Section III. LUBRICATION AND WEATHERPROOFING

#### 35. Lubrication Instructions (fig. 14)

*Caution:* Avoid contacting lubricating oil or grease with material such as rubber, paint, and certain plastics on which the lubricant may have a solvent effect. Avoid contacting lubricant with the dial drive cords.

a. Since Radio Receiver R-520/URR uses a dial drive system of simple design, very little lubrication is necessary. Should the three-section ganged tuning capacitor become stiff and cause the dial cord to slip, remove any grit between the capacitor and drive shaft bearing surfaces. Lubricate by applying Grease, Aircraft and Instruments (GL) to these parts. Do not allow lubricant to spread on capacitor plates or dial cord.

b. Grease (GL) contains a rust and corrosion inhibitor. It may be used in regions where the temperature ranges from  $-70^{\circ}$  F to  $+160^{\circ}$  F.

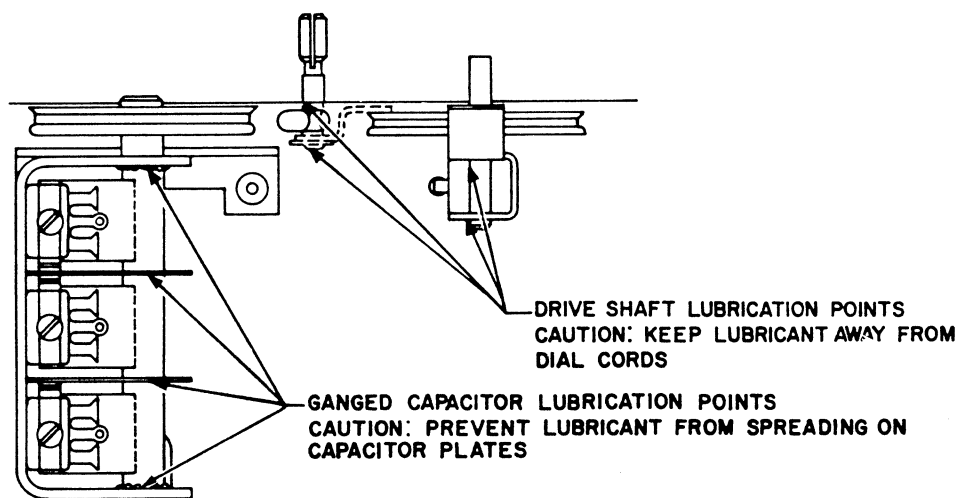

TM877-14

Figure 14. Lubrication points for Radio Receiver R-520/URR.

### **36. Weatherproofing Instructions**

*a.* GENERAL. Signal Corps equipment, when operated under severe climatic conditions such as prevail in tropical, arctic, and desert regions, requires special treatment and maintenance. Fungus growth, insects, dust, corrosion, salt spray, excessive moisture, and extreme temperatures are harmful to most materials.

*b.* TROPICAL MAINTENANCE. A special moistureproofing and fungiproofing treatment has been devised which, if properly applied, provides a reasonable degree of protection. This treatment is explained in TB SIG 13 and TB SIG 72. The equipment is given the moistureproofing and fungiproofing treatment at the factory and it is only necessary to use this treatment when parts are replaced or repaired.

*c.* DESERT MAINTENANCE. Special precautions necessary to prevent equipment failure in areas subject to extremely high temperatures, low humidity, and excessive sand and dust are explained in TB SIG 75.

*d.* WINTER MAINTENANCE. Special precautions necessary to prevent poor performance or total operational failure of equipment in extremely low temperatures are explained in TB SIG 66 and TB SIG 219.

*e.* LUBRICATION. The effects of extreme cold and heat on materials and lubricants are explained in TB SIG 69. Observe all precautions outlined in TB SIG 69 and pay strict attention to all lubrication orders when operating equipment under conditions of extreme cold or heat. Refer to paragraph 35 for detailed instructions.

### **37. Cabinet Finish**

Clean the outside of the cabinet with a mild solution of soap and water. Touch up scuffs and scratches with a good paste-type wax shoe polish of the proper color.

## **Section IV. TROUBLE SHOOTING AT ORGANIZATIONAL MAINTENANCE LEVEL**

### **38. Scope**

*a.* The trouble shooting and repair work that can be per-

formed at the organizational maintenance level (operators and repairmen) is necessarily limited in scope by the tools, test equipment, and replaceable parts issued, and by the existing tactical situation. Accordingly, trouble shooting is based on the performance of the equipment and the use of the senses in determining such troubles as burned-out tubes, cracked insulators, etc.

b. The paragraphs which follow in this section help in determining which of the components are at fault and in localizing the fault in that component to the defective stage or item, such as a tube or fuse.

### **39. Visual Inspection**

a. Failure of this equipment to operate properly will usually be caused by one or more of the following faults:

- (1) Improperly connected battery cable or power line cord plug.
- (2) Worn, broken, or disconnected cords or plugs.
- (3) Burned-out fuse.
- (4) Broken wires caused by excessive vibration.
- (5) Defective tubes.

b. When failure is encountered and the cause is not immediately apparent, check as many of the above items as is practicable before starting a detailed examination of the component parts of the system. If possible, obtain information from the operator of the equipment regarding performance at the time trouble occurred.

### **40. Trouble Shooting by Using Equipment Performance Checklist**

a. **GENERAL.** The equipment performance checklist (par. 41) will help the operator to locate trouble in the equipment. The list gives the items to be checked, the conditions under which the item is checked, the normal indications and tolerances of the correct operation, and the corrective measures the operator can take. *To use this list, follow the items in numerical sequence.*

b. **ACTION OR CONDITION.** For some items, the information given in the action or condition column consists of various switch

and control settings under which the item is to be checked. For other items it represents an action that must be taken to check the normal indication given in the normal indications column.

*c.* **NORMAL INDICATIONS.** The normal indications listed include the visible and audible signs that the operator should perceive when he checks the items. If the indications are not normal, the operator should apply the recommended corrective measures.

*d.* **CORRECTIVE MEASURES.** The corrective measures listed are those the operator can make without turning in the equipment for repairs. A reference in the table to chapter 5 indicates that the trouble cannot be corrected during operation and that trouble shooting by an experienced repairman is necessary. If the set is completely inoperative or if the recommended corrective measures do not yield results, trouble shooting is necessary.

## 41. Equipment Performance Checklist

## a. POWER LINE OPERATION.

	Item No.	Item	Action or condition	Normal indications	Corrective measures
P	1	Volume control and on-off switch.	Set to off position (maximum counterclockwise position). Swing front cover of case up into operating position. Extend antenna to maximum height. Set switch S5 on adapter for line voltage to be used. Plug cord into proper line voltage source.		
R	2	Loop antenna.			
E	3	Whip antenna.			
P	4	Power supply adapter.			
A	5	Power line cord.			
R	6	Volume control and on-off switch.	Set volume control to maximum clockwise position.	Neon pilot light is illuminated.	Check fuse. Replace dial light. Reverse line cord plug.



a. POWER LINE OPERATION (contd).

E	7	Tone control.	Set all tone control switches to the right (normal operation).	Normal frequency response.	
Q	8	Band selector switches.	Press each of seven band selector switches, turn tuning control.	Signals heard in loudspeaker.	If signals are weak or not obtained, replace tubes in receiver; check power line voltage and battery pack condition.
U	9	Tone control switches.	Operate each switch.	Tonal variations.	If no tonal variations are noticed, check switches, chapters 4 and 5.
I	10	Volume control.	Turn counterclockwise.	Volume decreases.	Check volume control (chap. 4 and 5).
P	11	Headsets.	Headsets plugged into jack J3.	Speaker becomes inoperative; signals heard in headsets.	If headsets do not operate, check jack, J3, contacts.
E	12	External antenna.	Connect to antenna terminal. (For power line operation, disconnect power cord plug from line while making connection.)	Increased signal pickup on bc and sw bands.	Check antenna.
R	13	External ground.	Connect to ground terminal. (For power line operation, disconnect power cord plug from line while making connection.)	Minimum line noise and hum pickup.	Check ground connection.
F					
O					
R					
M					
A					
N					
C					
E					

a. POWER LINE OPERATION (contd).

	Item No.	Item	Action or condition	Normal indications	Corrective measures
S	14	Volume control and on-off switch.	Turn to off position (full counterclockwise position of volume control).	No signals are heard. Pilot light goes out.	
T	15	Power line cord.	Roll up and stow cord near headset jack J3 so that back cover of case will close firmly.		
O	16	Tuning control.	Rotate tuning control knob counterclockwise until dial pointer is at low-frequency end of tuning range.		
P					

b. BATTERY OPERATION.

Item No.	Item	Action or condition	Normal indications	Corrective measures
1	Volume control and on-off switch.	Set to off position (maximum counterclockwise position).		
2	Loop antenna.	Swing front-cover of case up into operating position.		
3	Whip antenna.	Extend antenna to maximum height.		
4	Power line cord.	Plug power line cord into switch S4 (fig. 4).		
5	Batteries.	Connect batteries (par. 13).		
6	Volume control and on-off switch.	Set volume control to maximum clockwise position.	Neon pilot light glows.	Replace batteries. Replace dial light.

For EQUIPMENT PERFORMANCE and STOP checklist, see Items No. 7 through 16 in subparagraph a above.

## CHAPTER 4

### THEORY

---

#### 42. Block Diagram (fig. 15)

*a.* GENERAL. Radio Receiver R-520/URR is a portable superheterodyne receiver designed to receive a-m signals. The frequency range is given in paragraph 4. A complete schematic diagram is shown in figure 40. The tuning system consists of an antenna section, an r-f stage which uses a 1U4 tube, and a 1L6 pentagrid converter which operates as a combination mixer and h-f (high-frequency) oscillator. A different mode of tuning and tracking is used on each of the three groups of bands (broadcast band, continuous coverage short-wave bands, and the spread bands). The block diagram shows the signal path through the receiver.

*b.* FIRST R-F AMPLIFIER. The signal is fed from the antenna to the tuned r-f amplifier tube, V1. The r-f amplifier serves to increase the signal voltage, provides isolation between the oscillator section of tube V2 and the antenna, and also stops unwanted signals (image frequencies) from entering the converter.

*c.* CONVERTER. The signal from the r-f amplifier is fed to the mixer section of the combination mixer and oscillator tube, V2. The oscillator section of tube V2 produces an h-f oscillator voltage which is 455 kc higher than the signal frequency on the broadcast and the two continuous coverage bands, and 455 kc lower on the four spread bands (subpar. *a* above). This voltage is combined with the received signal in the mixer section of tube V2 to produce a difference beat frequency of 455 kc which then is amplified by i-f amplifier tube V3.

d. I-F AMPLIFIER. The i-f amplifier is a high-gain circuit which is fixed tuned to the frequency difference between the h-f oscillator and the incoming r-f signal, and is thus a constant, single-frequency amplifier, operating on 455 kc. Most of the signal amplification occurs in the i-f amplifier.

e. DETECTOR AND FIRST A-F AMPLIFIER. The amplified signal from the i-f amplifier is fed to the detector tube, V4, for demodulation. V4 is a dual tube, which serves as a detector and a first a-f (audio-frequency) amplifier. The detector stage also produces the avc (automatic volume control) voltage which automatically controls the gain of the receiver by regulating the bias voltage to the grids of tubes V1, V2, and V3.

f. FINAL AUDIO POWER AMPLIFIER. The audio signal from V4 is fed to audio-output stage V5 for power amplification. The output of the power amplifier, V5, is applied across an impedance-matching output transformer which permits the use of headsets or loudspeaker.

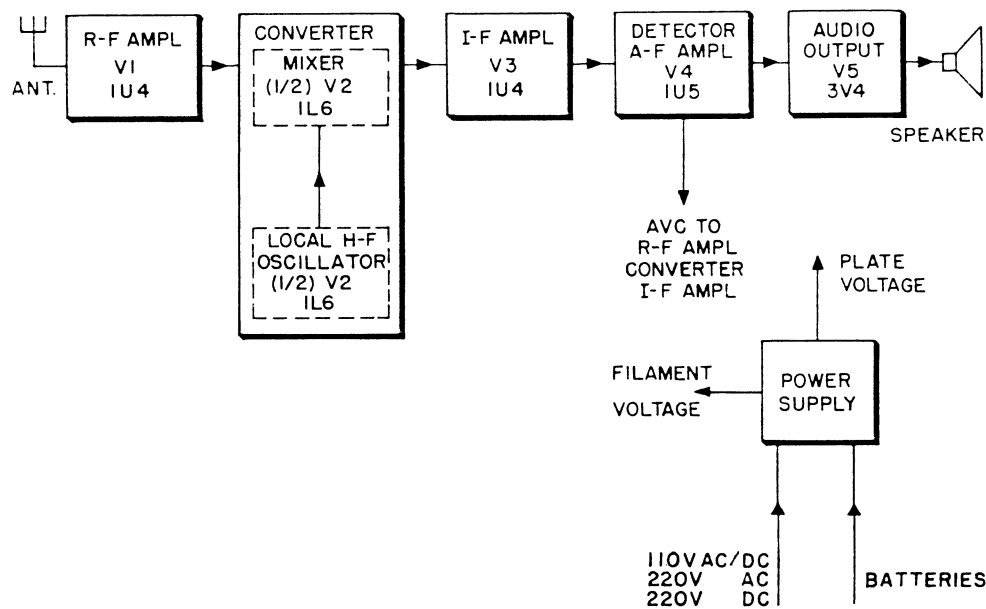

TM877-15

Figure 15. Radio Receiver R-520/URR, block diagram.

### 43. Tuning Circuits

a. The tuning range of the broadcast band is from 540 to 1,600 kc and tuning is provided by means of ganged tuning capacitor C2, sections A, C, and E. Figure 16 shows the r-f and converter stages for broadcast operation when BC push button S1A is pressed. The switch sections actually are arranged in line (fig. 34), but are shown rearranged in figure 16 to facilitate circuit discussion (pars. 44, 45, and 46).

b. The tuning ranges of the two continuous coverage bands are from 2 to 4 mc and 4 to 8 mc and tuning is provided by means of the same gang tuning capacitor as used on the broadcast band. Both continuous coverage bands have similar antenna, r-f, and converter circuits. Figure 17, which is used to facilitate discussion (par. 47), shows the r-f and converter stages for 4 to 8-mc operation (push button S1B pressed). Figure 35 shows the circuit with the sections of S1B drawn in line.

c. The tuning ranges of the four spread bands are from 9.4 to 9.8 mc (31 M), 11.6 to 12 mc (25 M), 14.9 to 15.5 mc (19 M), and 17.5 to 18.1 mc (16 M). Tuning is provided by means of the same ganged tuning capacitor as used on the broadcast band. All four spread bands have similar antenna, r-f, and converter circuits. Figure 18, which is used to facilitate discussion (par. 48), shows the r-f and converter stages for 16 M operation (push button S1D pressed). Figure 36 shows the circuit with the sections of S1D drawn in line.

#### 44. Broadcast Antenna Stage (fig. 16)

The tuned antenna circuit consists of antenna loop E2, and resistor R1 in series with antenna loading coil L4 and ganged tuning capacitor C2A. The junction of E2 and L4 is connected to the control grid of the 1U4 r-f tube through capacitor C30 which isolates the control grid of the 1U4 r-f tube for avc action. Antenna loading coil L4 increases the tuning range of the circuit. Capacitor C3 and resistor R1 form an impedance-matching network for any external long-wire antenna and serve to minimize any change of loop antenna tracking caused by different lengths of external antennas. Trimmer capacitor C2B is mounted on top of ganged tuning capacitor C2A and is set to track at the h-f end of the broadcast band. Capacitor C1 isolates the power line from a direct ground connection when operating from a power line source.

#### 45. Broadcast R-f Stage (fig. 16)

Plate voltage for the r-f stage is supplied from the high B+ bus (par. 59) through primary winding CD of coil L1 and damping resistor R3. Secondary winding AB of coil L1 is tuned by ganged capacitor C2C. Primary winding CD of coil L1, in series with R3, forms the plate load for V1. The filament of V1 is returned to B— for r-f through capacitor C9. Avc voltage to control the gain of the r-f stage is supplied through isolating resistor R2 (par. 53). Screen voltage for the r-f stage is supplied directly from the low B+ bus (par. 59). Trimmer capacitor C2D, mounted on top of

ganged tuning capacitor C2C, is set to track at the h-f end of the broadcast band.

#### **46. Broadcast Converter Stage (fig. 16)**

The combined functions of mixer and h-f oscillator are performed by pentagrid converter V2, which uses a type 1L6 tube. The filament and first two grids, acting as a triode, comprise the oscillator section. Grid 1 (pin 4) functions as the oscillator grid, while grid 2 (pin 3) functions as the oscillator plate. Plate voltage for the oscillator section is supplied from the low B+ bus through primary winding EF of coil L2. Grid leak bias is provided by the combination of C12 and R6. Avc voltage to control the gain of the converter stage is supplied through isolating resistor R26 (par. 53). The filament is returned to B— for r-f through capacitor C9. The oscillator is the tuned-grid plate-tickler feedback type and its operating frequency on the broadcast band is 455 kc higher than the incoming signal frequency. Section EF of coil L2 is the oscillator plate feedback winding and section DB is the tuned-grid winding. Windings GH and AC of coil L2, and coil L3, are not used on the broadcast band. Tuning capacitor C2E is in series with capacitor C13 and both shunt grid winding DB. Capacitor trimmer C2F is mounted on top of ganged tuning capacitor C2E and is set to calibrate the oscillator at the h-f end of the broadcast band. C13 is the 600-kc padder. Mixing action between the oscillator and the r-f signal from V1 occurs within the electron stream of converter tube V2. The difference frequency (i.f.) is taken from the plate (pin 2) and applied to i-f transformer T1.

#### **47. Continuous Coverage Bands (fig. 17)**

The two continuous coverage tuning ranges are from 2 to 4 mc and 4 to 8 mc. The antenna, r-f, and converter stages are tuned by ganged tuning capacitor C2A, C2C, and C2E. Both tuning ranges have similar antenna, r-f and converter circuits and therefore only the 4 to 8 mc circuit will be discussed.

*a.* ANTENNA STAGE (4- to 8-mc). The antenna circuit consists of coil L5 shunted by tuning capacitor C2A and trimmer C2B. Coupling to the control grid of the 1U4 r-f tube V1 is provided by capacitor C30. The telescopic whip antenna is coupled to antenna coil L5 through capacitor C27 and an external antenna (when used) is coupled to antenna coil L5 through capacitor C28. Coil L5 is set to track at the low-frequency end of the tuning





range. Trimmer capacitor C31A in series with parasitic suppressor R24 is set to track at the h-f end of the tuning range.

*b.* R-F STAGE (4- to 8-mc). The plate, screen, avc, and filament circuits of the r-f stage are as described in paragraphs 53, 58, and 59. The r-f stage is inductively coupled to the converter stage by r-f coil L1 and capacitively coupled by capacitor C6. R-f coil L12 is shunted across the secondary of broadcast coil L1 through a section of band selector switch S1B. Tuning is provided by gang tuning capacitor C2C. Coil L12 is set to track at the low-frequency end of the tuning range and trimmer capacitor C35A is set to track at the h-f end of the tuning range.

*c.* CONVERTER STAGE (4- to 8-mc). The plate, screen, avc, and filament circuits of the converter stage are as described in paragraphs 53, 58, and 59. When the 4- to 8-mc continuous coverage band is selected by the band selector switch, oscillator coil winding L18A is effectively shunted across the primary of broadcast oscillator coil EF through series capacitors C37 and C39. At the same time oscillator coil winding L18B is shunted across the secondary of broadcast oscillator coil DB through fixed oscillator padder capacitor C39. Secondary winding AC of coil L2 is shunted by capacitors C14 and C38 to eliminate undesirable resonant effects. L3 is a high-impedance loading coil that improves the operation of the h-f oscillator on short wave. Tuning is provided by ganged tuning capacitor C2E. The core of coil L18A, L18B is set to calibrate at the low-frequency end of the 4- to 8-mc band. Trimmer capacitor C40A is set to calibrate at the h-f end of the 4- to 8-mc band. The oscillator frequency is 455 kc higher than the incoming signal frequency. The oscillator signal and the r-f signal are mixed within the electron stream of converter tube V2. The difference frequency (i.f.) is taken from the plate (pin 2) and applied to i-f transformer T1.

#### **48. Spread Bands (fig. 18)**

The four spread bands tune as follows: 31 M (9.4 to 9.8 mc), 25 M (11.6 to 12 mc), 19 M (14.9 to 15.5 mc), 16 M (17.5 to 18.1 mc). The antenna, r-f, and converter stages are similar in operation on each of the four spread bands and therefore only the 16 M circuit will be discussed.

*a.* ANTENNA STAGE (16 M). The antenna circuit is made up of antenna coil L7 shunted by the two series capacitors C32 and C33. Tuning capacitor C2A with its trimmer C2B is shunted

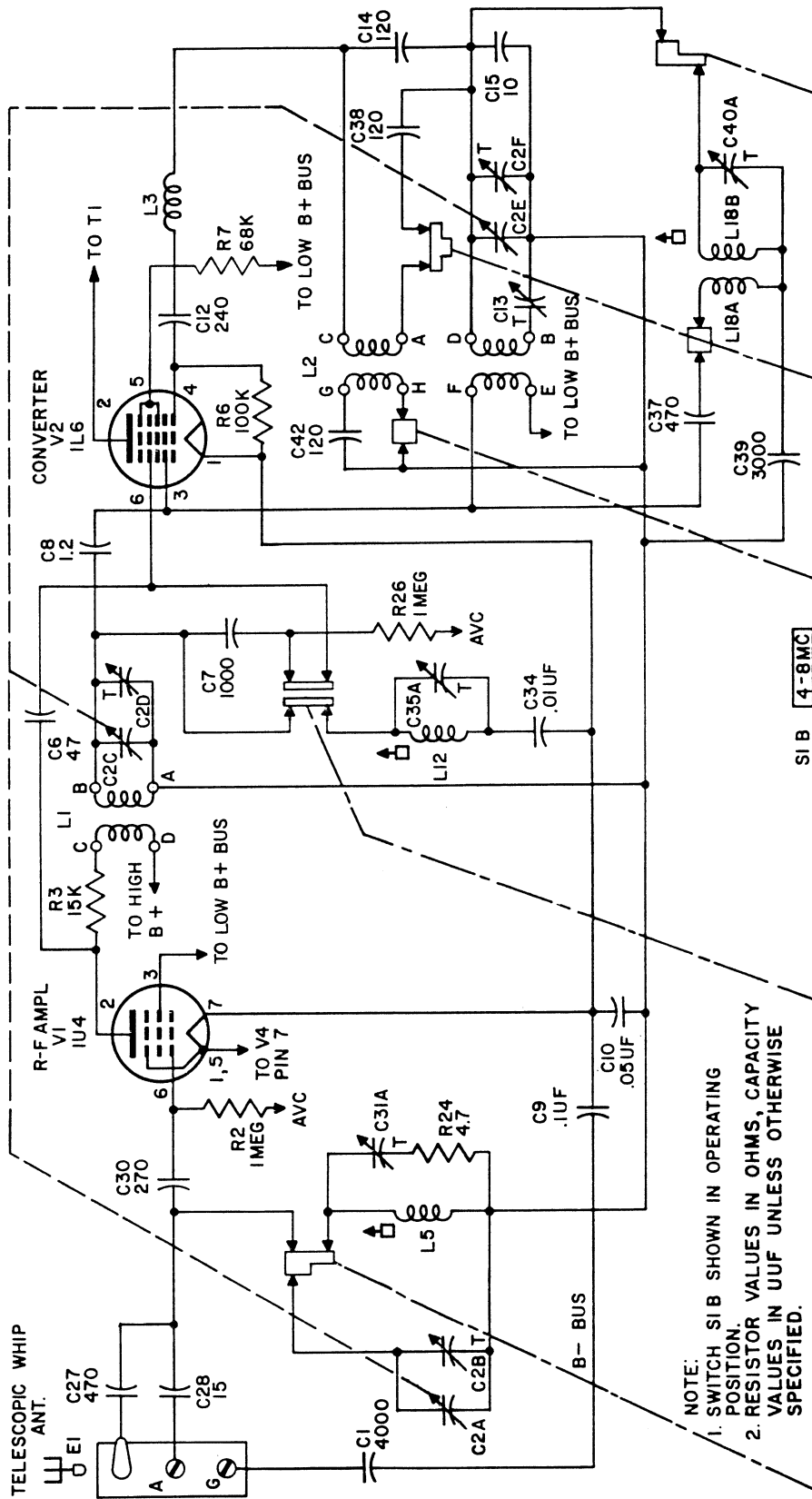

TM877-17

Figure 17. 4- to 8-mc band antenna, r-f amplifier, and converter circuits.

across capacitor C32 to provide band spreading over a narrow frequency range. This circuit is coupled to the control grid of 1U4 r-f amplifier tube V1 through capacitor C30. Antenna coil L7 is set to track at the center of the tuning range. The telescopic whip antenna is connected through coupling capacitor C27 to the high side of antenna coil L7. When an external antenna is used, coupling to the high side of the antenna coil is provided by capacitor C28.

*b.* R-F STAGE (16 M). The plate, screen, avc, and filament circuits of the r-f stage are as described in paragraphs 53, 58, and 59. The r-f circuit consists of r-f coil L14 in series with isolating capacitors C34 and C36. The coil is set to track at the center of the band. The circuit is not tuned by ganged capacitor C2C. The plate of the 1U4 r-f tube is coupled to the control grid of converter tube V2 through capacitor C6 and the high side of r-f coil L14 is tied to this same point through capacitor C36. L11 is an r-f choke coil which acts as a fixed grid load on spread-band operation. It is shunted across the r-f coil L14 through capacitors C34 and C36. Since it has a low d-c resistance and a high impedance to short-wave frequencies, it creates a high-loading effect to the short-wave frequencies and its low d-c resistance prevents the control grid of the 1L6 converter tube from accumulating any grid charge.

*c.* CONVERTER STAGE (16 M). The plate, screen, and filament circuits of the converter stage are as described in paragraphs 53, 58, and 59. No avc voltage is applied to the converter stage on the spread bands since the mixer grid (pin 6) is returned directly to the filament through coil L11. This allows the converter to operate at the point of maximum sensitivity and avoids the possibility of h-f oscillator shift which might result when avc voltage is applied to a converter stage. The basic oscillator circuit is a modified tuned-grid plate-tickler feedback type. Oscillator coil L20 is in series with the short-wave secondary winding AC of coil L2. Both coils are shunted across the broadcast coil secondary BD through fixed padder capacitors C42 and C14. The series shunt combination of capacitors C14, C15, C42, and gang tuning capacitor C2E with trimmer C2F results in band spreading over a narrow frequency range. The broadcast oscillator coil secondary BD is left in the circuit to simplify band switching and does not affect circuit operation. On short-wave frequencies, broadcast primary winding EF acts as a plate choke for the oscillator section. Oscillator coil L20 is set to track at 17.8mc.

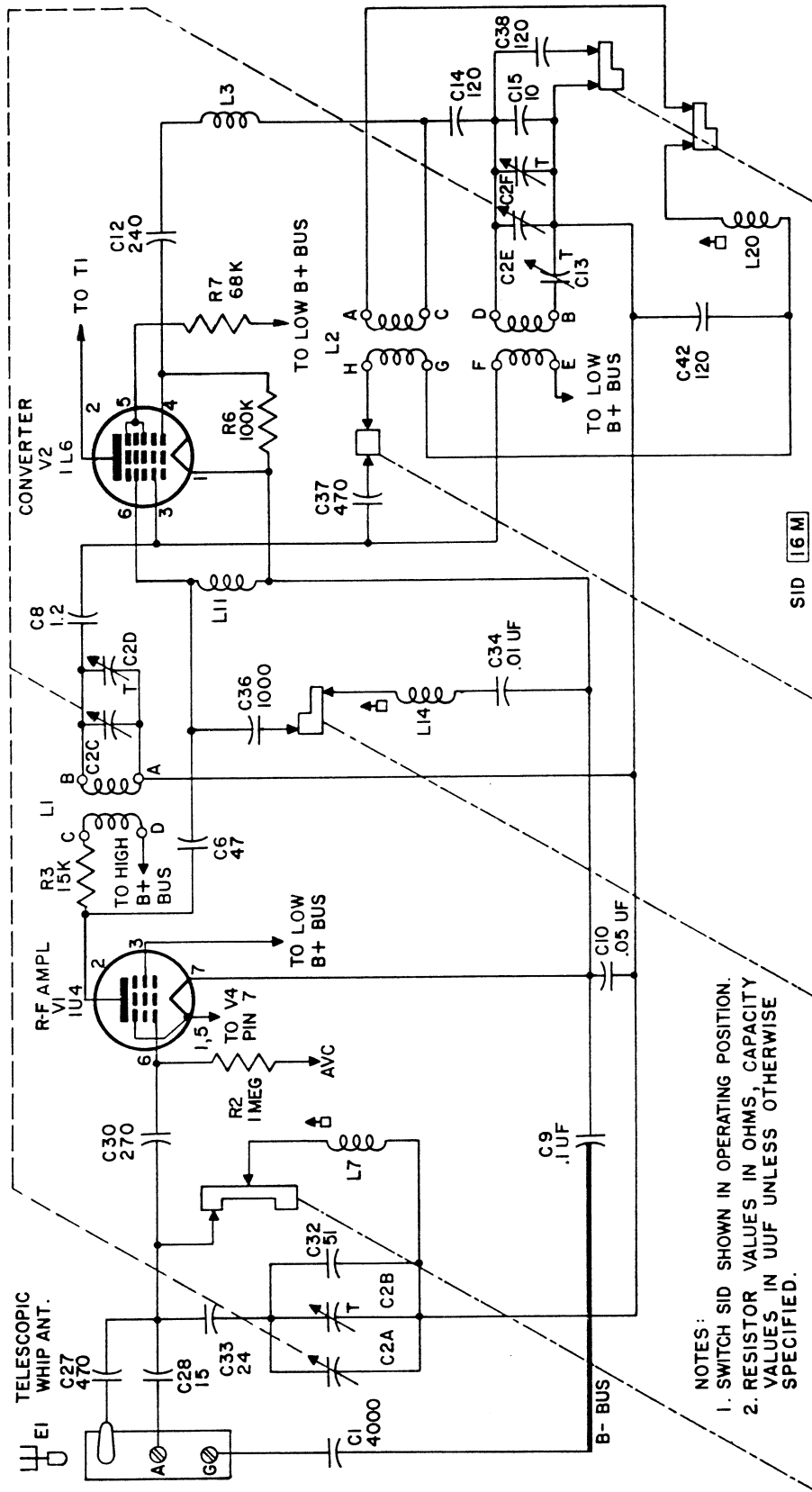

NOTES:  
 1. SWITCH SID SHOWN IN OPERATING POSITION.  
 2. RESISTOR VALUES IN OHMS, CAPACITY VALUES IN UUF UNLESS OTHERWISE SPECIFIED.

SID 16 M

TM877-18

Figure 18. 16 M band antenna, r-f amplifier, and converter circuits.



output stage. Capacitor C23 bypasses the plate of the amplifier for radio frequencies. Plate voltage for the pentode amplifier section is supplied through voltage-dropping resistor R4. Additional filtering is provided by capacitor C25. The action of the avc circuit is discussed in paragraph 53.

### 51. Audio Output (fig. 20)

The audio signal from the detector-amplifier is applied to the grid of the 3V4 (V5) audio-output stage across grid load resistor R20. Screen voltage is supplied directly from the high B+ bus. Plate voltage also is provided from the high B+ bus through the primary winding of output transformer T3. Capacitor C45C bypasses the plate and screen voltage source for audio frequencies. The correct grid bias is obtained by returning R20 to a point on the series filament circuit (par. 54). The secondary of transformer T3 is coupled to loudspeaker LS1 through the normally closed contacts of jack J3. For headset operation, the loudspeaker is disconnected automatically when the phone plug is inserted in jack J3.

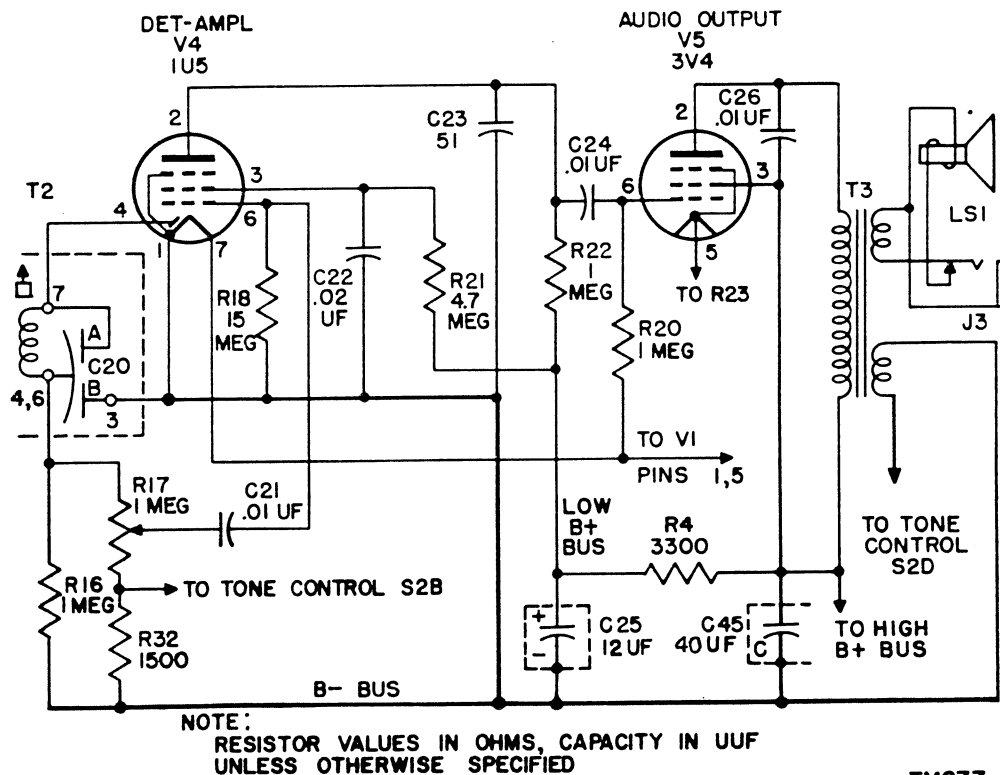

TM877-20

Figure 20. Detector-amplifier and audio output stages.

## 52. Tone Control Circuit (fig. 21)

a. The tone control circuit depends for its operation on an inverse feedback voltage that is fed back to the volume control through a resistor-capacitor network from the tertiary winding on output transformer T3. The tone control resistor-capacitor network consists of R16, R17, R32, R33, R34, R35, and capacitors C47, C48, and C49. The function of the four-tone control switches is to vary the resistor-capacitor network frequency characteristic which results in a change of a-f response. For example, when BASS tone control switch S2B is open, more high audio than low audio frequencies are fed back. The high audio frequencies are suppressed because they are fed back out of phase and a bass boost effect results. Since capacitor C48 has a higher reactance to the low audio frequencies, the low frequencies are effectively boosted when the BASS switch, S2B, is open. When switch S2B is closed, capacitor C48 is shorted out eliminating the bass boost and resulting in increased treble response.

b. Resistor R33 is a limiting resistor and is used to prevent regeneration at the very low audio frequencies. Resistor R35 limits the amplitude of the audio frequencies fed back to the volume control circuit. When the ALTO switch, S2D, is open, R35 is placed in series with the feedback voltage and the output level of the low boost is reduced effectively. Capacitor C47 bypasses the higher audio frequencies around R16 when TREBLE switch S2A is closed. Capacitor C49 passes the higher frequencies more readily and gives a bass boost when switch S2C is closed because of the inverse feedback voltage. When switch S2C is closed, capacitor C49 is shunted across resistor R34 causing a greater inverse feedback voltage of the high and middle frequencies. The audio gain at these high and middle frequencies is reduced by this inverse feedback. Since the audio gain at the lower audio frequencies is not affected, the bass has been boosted in relation to the middle and higher audio frequencies.

## 53. Avc System (fig. 22)

a. The avc system controls the gain of the r-f, converter, and i-f stages. Figure 22 shows the avc network on broadcast and continuous coverage, 2 to 4 and 4 to 8-mc bands. On spread-band operation, avc action for the r-f and i-f stages is the same but is eliminated for the converter stage. The converter control grid is switched through the band selector switch from grid resistor R26 over to r-f choke coil L11 (fig. 18). Under these

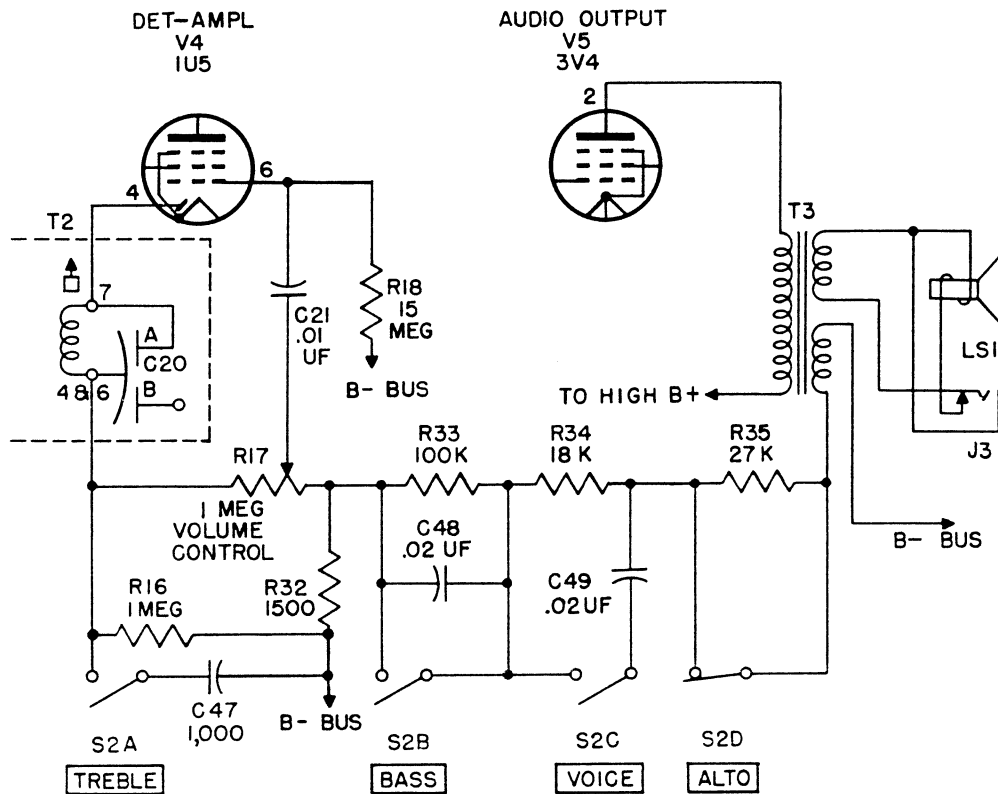

NOTES:

1. TONE CONTROL SWITCH POSITIONS SHOWN FOR NORMAL RESPONSE. (ALL FOUR BUTTONS OF SWITCH S2 SET TO THE RIGHT ON FRONT PANEL).
2. RESISTOR VALUES IN OHMS, CAPACITY VALUES IN UUF UNLESS OTHERWISE SPECIFIED.

TM877-21

Figure 21. Tone control circuit.

conditions, 1L6 converter tube V2 operates at the point of maximum sensitivity.

b. Resistors R16, R17, and R32 form the diode load circuit across which the avc voltage is developed. Three different levels of avc voltages are obtained from a voltage-divider network which is connected between the diode load circuit and different points of the filament circuit to develop the correct level of avc voltage and correct operating bias for each stage.

c. To prevent r-f overload and distortion, the greatest portion of avc voltage is fed back to the control grid of the r-f amplifier tube V1. The next greatest portion of avc voltage is fed back to the control grid of the mixer tube, V2, and the smallest portion of avc voltage is fed back to the i-f amplifier control grid of V3.

d. The maximum amount of avc voltage developed across the diode load is fed back to the control grid of V1 from the junc-



tion of R19 and R15 through isolation resistor R2. Resistors R14 and R10 are shunted by resistor R9 through part of the filament circuit. This branch is in series with resistor R13 to the diode load. This shunt divider network feeds avc voltage to the control grid of V2 through isolation resistor R26. From the junction of R14 and R10 the smallest portion of avc voltage is fed back to the control grid of V3.

#### 54. Bias System (fig. 22)

*a.* The avc and bias voltages for the receiver are tied together in a combination bridge network to supply the proper bias voltage to each tube. The common B— bus of the receiver is used as the point of zero voltage. Bias voltage for the various tubes is provided by returning the control grid to the appropriate point in the complex voltage divider formed by the series tube filaments and the avc resistor network. Filament and bias voltage are derived from the 8.4-volt d-c filament supply (par. 58).

*b.* Avc voltage is developed across the diode load resistors R16, R17, and R32, when an i-f signal is fed into the T2 secondary winding. The resistance network proportions the avc voltage to each control grid. Avc action reduces the gain of the r-f converter and i-f stage and prevents overload and distortion on strong input signals. Normally, a potential of —.25 volt is developed across diode load resistor R16. The control grid to B— voltage of each tube is determined by the resistance networks between the diode plate and the various control grids.

*c.* Since the filament voltage on direct heater-type tubes varies along the physical length of the filament, the center of the filament is used as a reference point when measuring the grid bias EG. The filament center-to-B— voltage is determined by the electrical position the tube occupies in the series filament circuit.

*d.* The difference between the control grid and filament center voltage is the operating grid bias, EG, of each tube.

*e.* On spread-band operation there is no avc applied to the control grid of V2 (par. 48). The grid return which normally goes to R26 is switched to r-f choke coil L11 and returns to the negative end of its own filament (fig. 18).

*f.* The grid bias on the 3V4 power-amplifier tube is obtained by connecting the grid d-c return through resistor R20 to

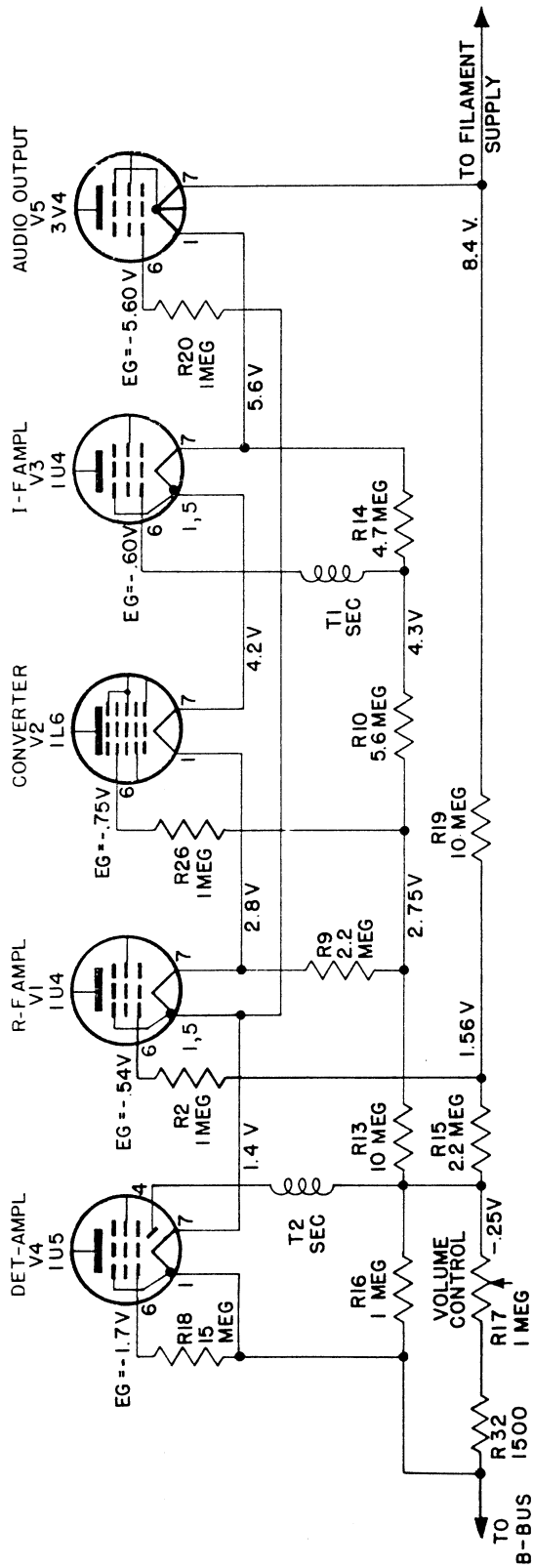

NOTES:

1. RESISTOR VALUES IN OHMS UNLESS OTHERWISE SPECIFIED.
2. ALL VOLTAGES ARE CALCULATED VALUES UNDER NO SIGNAL CONDITION.
3. FILAMENT CENTER VOLTAGES AND GRID RETURN VOLTAGES ARE REFERRED TO B- BUS.
4. OPERATING GRID BIAS 'EG' IS THE DIFFERENCE BETWEEN THE FILAMENT CENTER VOLTAGE AND THE GRID RETURN VOLTAGE FOR EACH TUBE.
5. IN BAND-SPREAD OPERATION [16M] [19M] [25M] [31M] NO AVC VOLTAGE IS APPLIED TO V2.

TM877-25

	VOLTAGES		
	FILAMENT CENTER	GRID RETURN	EG
DET-AMPL	V4 IU5	-1.0 V	-1.7 V
R-F AMPL	V1 IU4	1.56V	-.54V
CONVERTER	V2 IL6	2.75V	-.75V
I-F AMPL	V3 IU4	4.30V	-.60V
AUDIO OUTPUT	V5 3V4	1.40V	-5.60V

Figure 22. Radio Receiver R-520/URR, avc and bias system.

the junction of the 1U4 r-f and 1U5 detector-amplifier filaments which is 1.4 volts dc positive with respect to B—. The 3V4 power-amplifier filament center is approximately 7.0 volts dc positive with respect to B—. This results in an operating bias EG of —5.6 volts on the grid of the 3V4 power-amplifier tube which is normal for class A audio operation for this type pentode. The operating bias EG of 1.7 volts on the control grid of the 1U5 detector-amplifier tube is the sum of the internal contact bias created by normal filament emission plus the voltage existing between the center of the 1U5 filament and B—. The contact bias across resistor R18 is approximately —1 volt and the filament center-to-B— voltage is .7 volt. The resultant operating grid bias, EG, is therefore —1.7 volts. Figure 22 shows the manner in which the remainder of the tubes receive their operating bias EG.

### 55. Power Control Circuit

Power for Radio Set R-520/URR is applied through switches S3A-S3B, S4, fuse F1, thermal resistor RT1, and power supply adapter Z1 which is plugged permanently into J2 (fig. 23). Adapter Z1 is shown schematically in figure 24. Switch S4, located on the chassis and to the rear of the speaker, changes both the B+ and filament circuits from external power to battery power when the power plug is inserted in socket S4. Switch S3A-S3B, which is mounted on the volume control, controls the application of power to the radio set. It completes both the filament and B+ circuits to the receiver. The receiver requires an 8.4-volt to 9-volt d-c source for the series filament string and a 90- to 105-volt d-c source for the B+ line. The power circuit supplies these potentials whether the set is operating from battery or from an external power line source. With switch S4 set for power line operation, section A of switch S3 connects one side of the power line to the B— bus, while section B completes the B+ circuit through fuse F1 and R36. With switch S4 set for battery operation, section A of S3 connects the grounded negative terminal of the battery system to the B— bus, while section B completes the B+ circuit to the positive terminal of the B battery.

### 56. External Power Source

a. Selenium rectifiers CR1 and CR2 (contained in power supply adapter Z1) change the a-c alternating line voltage to dc. The d-c output voltage from the rectifier is applied through surge limiting resistor R27 to the filter circuit consisting of C45A, RT1, and C45B. The output of the filter supplies 8.4 volts dc. to the

filament string through R30 and a section of S4 (fig. 25). Thermal resistor RT1 is in series with resistor R30 to the filament circuit of the receiver and tends to maintain a constant current flowing through the tube filaments despite variations in line voltage. Fuse F1 has a 3/16-ampere rating and protects the power supply from overload in the B+ and filament circuits. R28 is a bleeder resistor which discharges capacitor C45A when the power is turned off.

b. Power supply adapter Z1, plugged into receptacle connector J2 at the rear of the chassis, is in series with the power line. It consists of a three-position switch, S5; a selenium rectifier, CR2, and resistor R38A-B (fig. 24). The complete assembly is housed in a perforated metal can. Receptacle J2 is a closed circuit-type connector. Therefore if power supply adapter Z1 is removed, the receiver may be operated from a 110-volt ac- or d-c power source. When switch S5 is in the 110 V AC-DC position, plug connector P2 is shorted out and the power line is connected directly to the receiver. When switch S5 is in the 220 V DC position, resistor R38A-B and selenium rectifier CR2 are placed in series with the power line to lower the voltage to 110 volts, dc. When switch S5 is in the 220 V AC position, it shorts out resistor R38A leaving R38B and selenium rectifier CR2 in series with the line. Since filter capacitor C45A draws an appreciable amount of ripple current, the total current drawn through the line is greater on 220-volt a-c operation than on 220-volt d-c operation. Shorting out resistor R38A compensates for the additional voltage drop that would occur through the power supply adapter and maintains the correct line voltage to the set.

*Note.* The receiver will not operate on dc if the polarity of the power line cord plug is reversed, however, electrolytic capacitor C45A, B, and C will not be harmed by reversed currents because selenium rectifiers CR1 and CR2 have a high back resistance.

## 57. Battery Power Source

a. For battery operation, a B supply voltage of 90 to 99 volts and an A supply voltage of 9 volts are required for operation of the receiver. The battery supply voltages are fed to the receiver through both sections of switch S3, and switch S4 (fig. 23). The negative side of the B battery is connected to the positive side of the A battery. This connection boosts the effective B+ voltage by the amount of the A supply voltage (9 volts). When the power line plug is inserted into socket switch S4 for battery operation, all the switch contacts of S4 may not make or break simultaneously. If the B+ and A+ contacts (the two upper contacts of

switch S4) make contact before the A— contact (the lower contact of switch S4), the B battery will charge electrolytic capacitor C45C through the tube filaments and the closed contacts of S3A-S3B (fig. 23). When this occurs resistor R37 will limit the initial surge of charging current and thus prevent filament burnouts.

b. Resistor R29 which is connected from the B— bus of the receiver to chassis, forms a high-impedance path to the external power line. When the receiver is operating on batteries, the B— bus is shorted to the chassis through switches S3A and S4. Capacitor C46 minimizes signal and noise pick-up from the power line when the receiver is operating from an external power line (fig. 23).

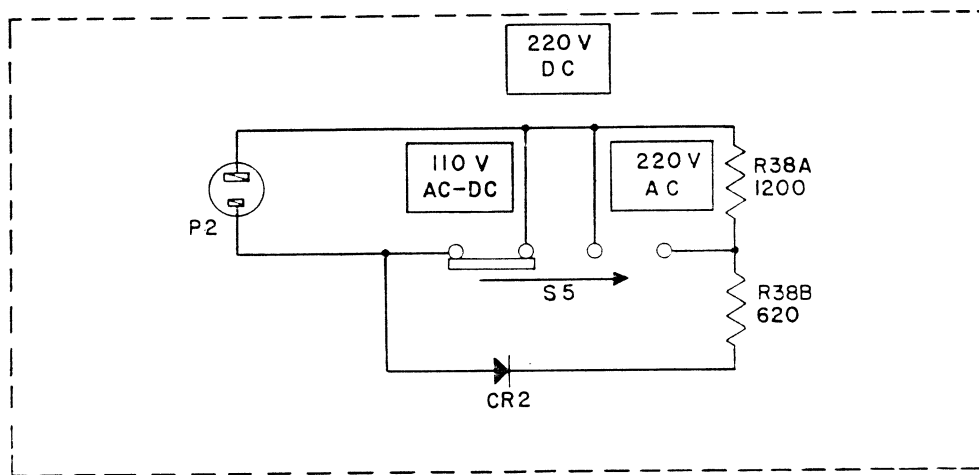

TM877-23

Figure 24. Power supply adapter unit.

### 58. Filament Circuit (fig. 25)

a. Radio Receiver R-520/URR uses four 1.4-volt and 2.8-volt 50-ma filament-type tubes. The tube filaments are connected across the voltage source in a series arrangement. On power line circuit operation, the 105-volt d-c rectifier output is dropped down to 8.4 volts dc through thermal resistor RT1 and resistors R30 and R27. On battery operation, 9 volts from the A battery are applied across the filament circuit. During normal operation, the plate and screen grid currents of a direct filament-type tube pass through the filament and add to the current flowing through the filament. This current accumulates toward the negative end of the filament. To prevent this extra current from burning out the filaments, shunting resistors R8, R5, R11, and R23 are incorporated in the circuit. R23 is placed across half of the filament of the 3V4

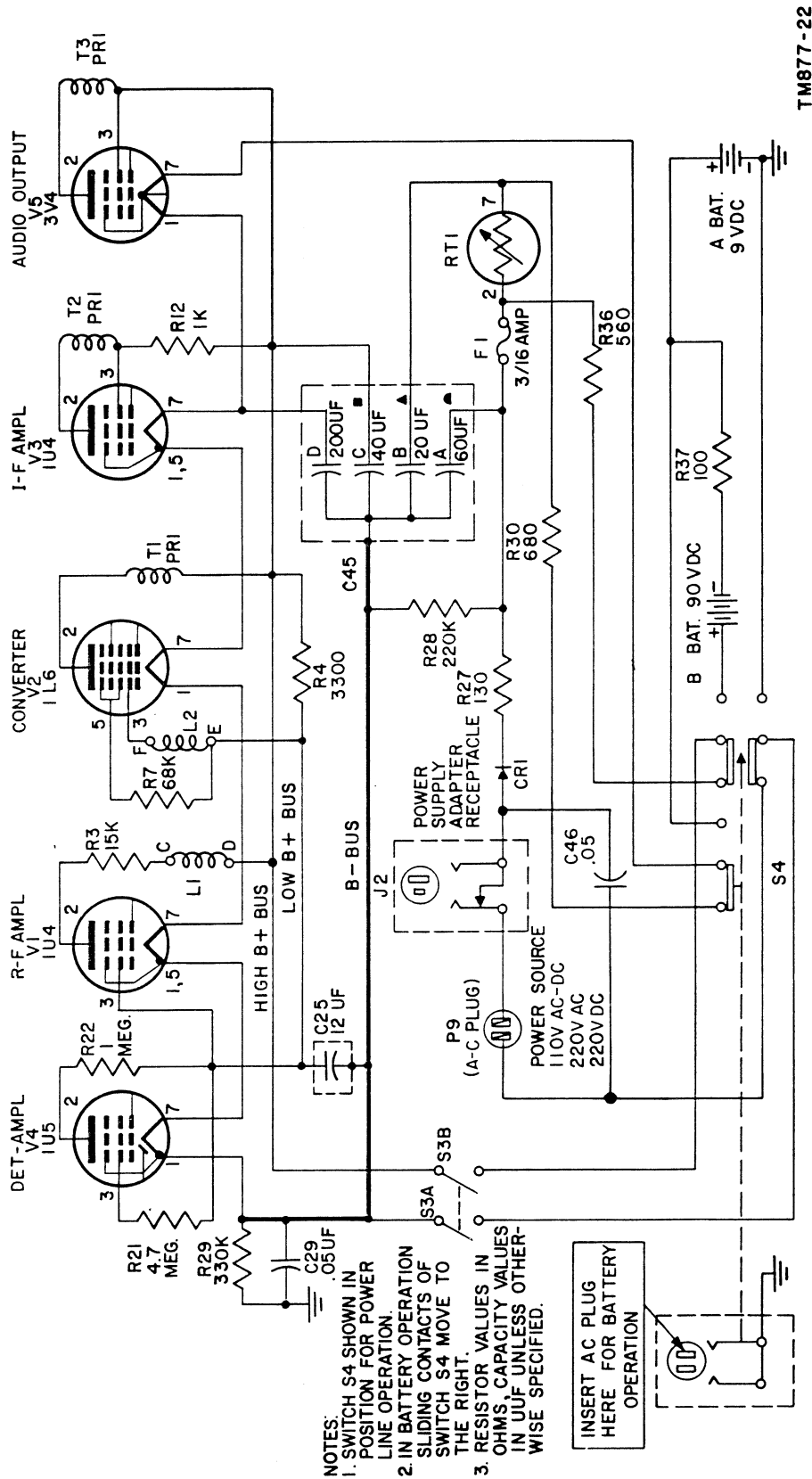

TM877-22

Figure 23. Power supply circuit.

audio-output tube because most of the plate and screen grid current accumulates near the negative end (pin 1). Resistors R5 and R11 are shunted across the filaments of V2 and V3 respectively, to shunt the relatively heavy plate current for the 3V4 output tube around the filaments of V2 and V3. One resistor, R8, is used across the filaments of V4 and V1 because their plate and screen grid currents are small.

b. Thermal resistor RT1 is a self-regulating resistor that helps to drop the 105-volt d-c power supply voltage down to the required 8.4-volts dc. Its internal resistance varies from 600 ohms to 1300 ohms with power line voltage variations of 90 volts to 127 volts and maintains a constant 50-ma current flowing in the filament circuit. Capacitor C45D is connected from pin 1 of V5 to the B— bus. Any audio voltage present in the output tube filament is prevented from entering and modulating the other tube filament circuits.

### 59. Plate and Screen Voltage Distribution (fig. 23)

Plate and screen voltage for the receiver is supplied either from the batteries or from the power line through the rectifier-filter circuits and is present at switch S3B (par. 55). When operating from batteries, 99 volts is applied to the high B+ bus through S3B. When operating from the power line, 105 volts is applied to the high B+ bus through S3B. The low B+ bus is supplied through dropping resistor R4 and is filtered by capacitor C25.

a. The high B+ bus feeds voltage to the plate and screen grid of V3, the 1U4 i-f amplifier through dropping resistor R12. It also feeds voltage to the plate of V2 through the primary winding of i-f transformer T1; to the plate of V1 through resistor R3 and the primary of r-f coil L1; to the plate of V5 through the primary of transformer T3 and to the screen of V5.

b. The low B+ bus feeds voltage to the anode grid of 1L6 converter tube V2 through winding EF of oscillator coil L2. It also feeds voltage to the screen grid of V2 through dropping resistor R7. The screen grid of r-f tube V1 receives voltage from the low B+ bus directly, and the screen grid of detector-amplifier tube V4 receives voltage through dropping resistor R21. Voltage from the low B+ bus also is supplied to the plate of V4 through plate load resistor R22. Capacitor C25 is a filter for the secondary bus and eliminates any hum voltage that may be present at that point.

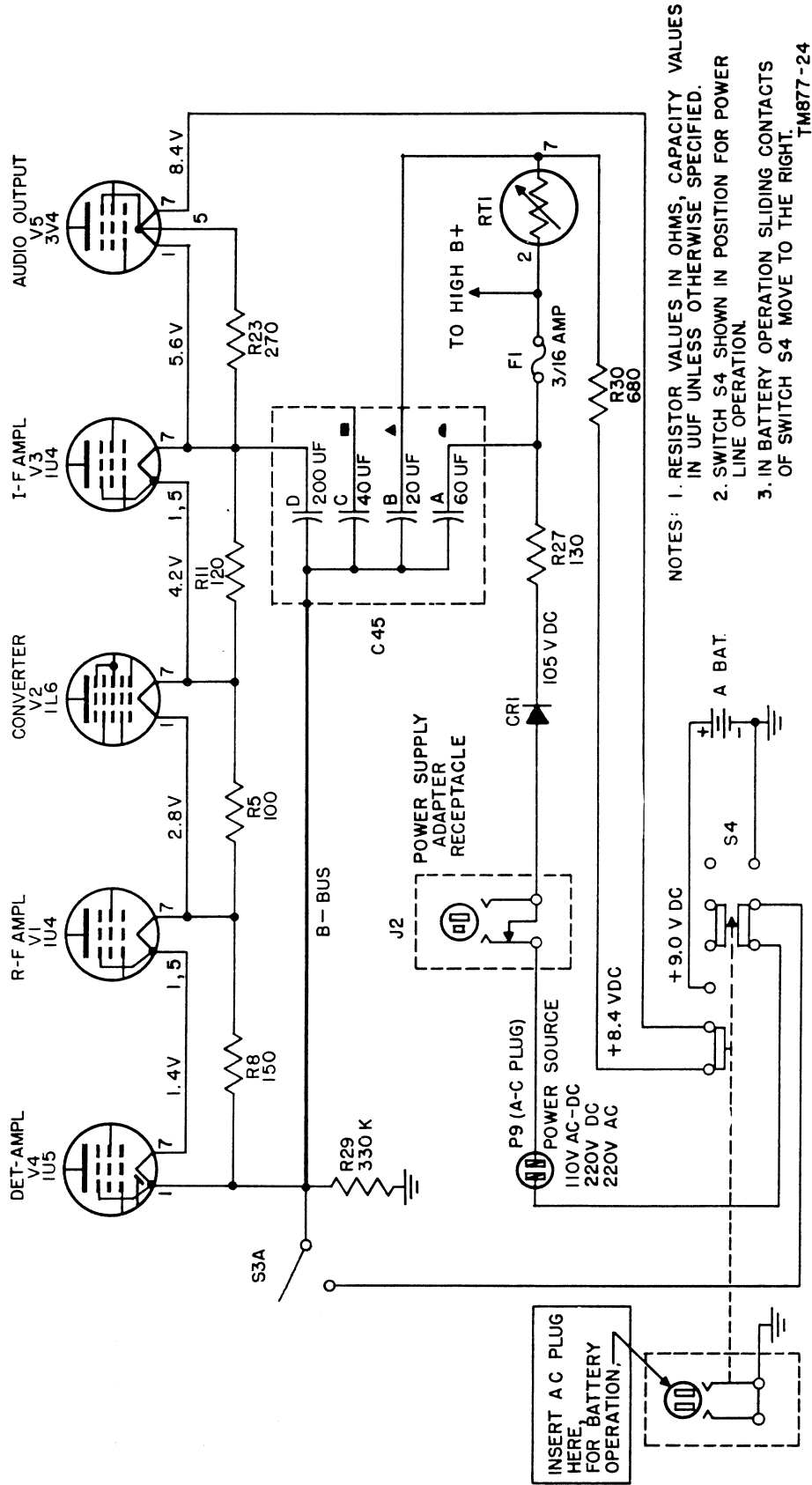

Figure 25. Filament circuit.



## CHAPTER 5

# FIELD MAINTENANCE INSTRUCTIONS

*Note.* This chapter contains information for field maintenance. The amount of repair that can be performed by units having field maintenance responsibility is limited only by the tools and test equipment available and by the skill of the repairman.

---

### Section I. TROUBLE SHOOTING AT FIELD MAINTENANCE LEVEL

*Warning:* The voltages present in the power supply are high enough to produce shock, and under certain conditions may be dangerous to life. When working on the equipment with voltages present, it is good practice to place the equipment on an insulated surface first, particularly if the skin is wet or damp from perspiration or water. Do not let the receiver touch other sets or equipment.

#### 60. Trouble-shooting Procedures

*a. GENERAL.* The first step in servicing a defective radio set is to sectionalize the fault. Sectionalization means tracing the fault to the *major component or circuit* responsible for the abnormal operation of the set. The second step is to localize the fault. Localization means tracing the fault to the defective *part* responsible for abnormal condition. Some faults such as burned-out resistors, r-f arcing, and shorted transformers often can be located by sight, smell, and hearing. The majority of faults, however, must be localized by *checking voltages and resistances*.

*b. COMPONENT SECTIONALIZATION AND LOCALIZATION.* The tests listed below aid in isolating the source of trouble. To be ef-

fective, the procedure should be followed in the order given. Remember that servicing procedures should cause no further damage to the receiver. First, trouble should be localized to a single stage or circuit. Then the trouble may be isolated within that stage or circuit by appropriate voltage, resistance, and continuity measurements. The service procedure is summarized as follows:

- (1) *Visual inspection.* The purpose of visual inspection is to locate any visible trouble. Through this inspection alone, the repairman frequently may discover the trouble, or determine the stage in which the trouble exists. This inspection is valuable in avoiding additional damage to the receiver which might occur through improper servicing methods and in forestalling future failures.
- (2) *Input resistance measurements.* These measurements (par. 66) prevent further damage to the receiver from possible short circuits. Since this test gives an indication of the condition of the filter circuits, its function is more than preventive.
- (3) *Operational test.* The operational test (par. 67) is important because it frequently indicates the general location of trouble. In many instances, the information gained will determine the exact nature of the fault. In order to utilize this information fully, all symptoms must be interpreted in relation to one another.
- (4) *Trouble-shooting chart.* The trouble symptoms listed in these charts (par. 68) will aid greatly in localizing trouble.
- (5) *Signal substitution.* The principal advantage of signal substitution (pars. 70 through 73) is that it usually enables the repairman to localize a trouble accurately and quickly to a given stage when the general location of the trouble is not immediately evident from the above tests.

(6) *Stage gain and sensitivity chart.* This chart (par. 76) can be used to localize obscure, hard-to-find troubles.

(7) *Intermittents.* In all these tests, the possibility of intermittents should not be overlooked. If present, this type of trouble may be made to appear by tapping or jarring the set. It is possible that the trouble is not in the radio itself but in the installation, or the trouble may be caused by external conditions. In this event, test the installation, if possible.

### 61. Trouble-shooting Data

Take advantage of the material supplied in this manual. It will help in the rapid location of faults. Consult the following trouble-shooting data:

Fig. No.	Description
22	Radio Receiver R-520/URR, avc and bias system.
25	Filament circuit.
26	Radio Receiver R-520/URR, chassis removal.
27	Voltage and resistance diagram.
28	Top view of chassis.
29	Bottom view of chassis.
32	Dial cord drive system.

### 62. Test Equipment Required for Trouble Shooting

The test equipment required for trouble shooting is listed below. The technical manuals associated with the test equipment also are listed.

Test equipment	Publication
Signal Generator Set AN/URM-25	NAV SHIPS 91283
Output Meter TS-585/U	TM 11-5017
Frequency Meter Set SCR-211-(* )	TM 11-300
Electronic Multimeter TS-505/U, or equal	TM 11-5511
Tube Tester I-177, I-177-A, or equal	TM 11-2627
Audio Oscillator TS-382A/U	TM 11-2684A
Multimeter TS-297/U	TM 11-5500
.05-uf (microfarad) capacitor, 400 vdcw	
.01-uf capacitor, 400 vdcw	
Low-impedance headset	

### 63. General Precautions

Observe the following precautions very carefully whenever servicing the radio receiver.

*a.* If available, use an isolation transformer between the power line and the receiver.

*b.* Be careful when the bottom of the chassis is exposed; dangerous voltages are present.

*c.* Disconnect the external power line cord from the outlet before making repairs.

*d.* When working on the top of the chassis, be careful not to bend the ganged tuning capacitor plates as this could cause a short or misalignment.

*e.* Do not overtighten screws which are inserted through or threaded into plastic materials. This might strip the threads or produce cracks.

*f.* When changing a component that is held by screws or nuts, always replace the lockwashers.

*g.* Careless replacement of parts often makes new faults inevitable. Note the following points:

- (1) Before a part is unsoldered, note the position of the leads. If the part, such as a transformer, has a number of connections, tag each of the leads.
- (2) Be careful not to damage other leads by pulling or pushing them out of the way.
- (3) Do not allow drops of solder to fall into the receiver, since they may cause short circuits.
- (4) A carelessly soldered connection may create a new fault. It is very important to make well-soldered joints, since a poorly soldered joint is one of the most difficult faults to find.
- (5) When a part is replaced in the r-f or i-f circuits, it must be placed exactly as the original. A

part which has the same electrical value but different physical size may cause trouble in h-f circuits. Give particular attention to proper grounding when replacing a part. Use the same ground as in the original wiring. Failure to observe these precautions may result in decreased gain or possible oscillation in the circuit.

#### **64. Chassis Removal (fig. 26)**

To remove the chassis from the case, perform the following steps:

*a.* Rotate the tuning control knob counterclockwise until the dial pointer is at the low-frequency end of the tuning range.

*b.* Remove the volume control and tuning control knobs.

*c.* Disconnect the battery cables and remove the batteries from the receiver.

*d.* Remove the four power cord adapters and bracket assembly (fig. 4).

*e.* Loosen the two captive screws that hold protective cover A 3 (fig. 4) to the chassis, and remove the cover.

*f.* Remove the wood screw that secures the band selector bracket to the wooden cabinet.

*g.* Remove the three chassis mounting screws and washers.

*h.* Disconnect the loop antenna cable from the socket at the rear of the chassis.

*i.* Remove the whip antenna by taking off the two nuts and washers that secure it to the cabinet.

*j.* Remove the chassis.

#### **65. Preliminary Inspection**

When a radio set is brought in from the field for check or repair, remove the receiver from the case and inspect as follows:

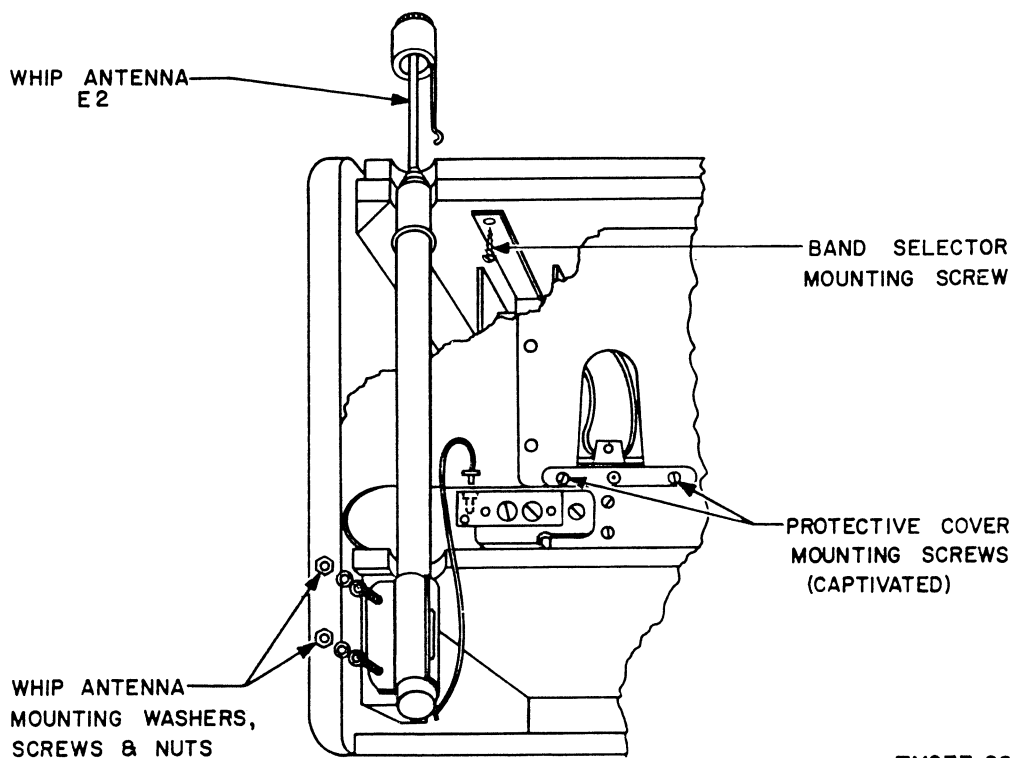

TM877-26

Figure 26. Radio Receiver R-520/URR, chassis removal.

- a. Examine for burned insulation and resistors. Examine for wax leakage and any discoloration of apparatus and wire.
- b. Inspect for broken connections to tube sockets, plugs, and other apparatus, as well as for defective solder connections. Examine for bare wires that touch the chassis or other wires.
- c. Be sure that the markings on the tubes in the various sockets correspond to the correct tube types for these positions as given in the instruction book. Replace or interchange any tubes which have the wrong numbers. Replace broken tubes. Inspect for loose tube socket contacts.
- d. Inspect the fuse. Check carefully for short circuits whenever a blown fuse is found.
- e. Inspect the dial mechanism. Be sure that the dial turns smoothly.
- f. Check all switches and controls for ease of operation.
- g. Inspect all power plugs and cables. Replace or repair any plugs or cables that are broken.
- h. Inspect for loose or missing screws.

## 66. Voltage and Resistance Measurements (fig. 27)

*a.* Trouble within the receiver often may be detected by checking the resistance of the filament and high-voltage circuits before applying power to the equipment, thereby preventing damage to the power supply portion of the receiver. These measurements are to be made with no power applied to the receiver and with the battery cables disconnected. The readings may vary slightly in some instances from those listed. However, a reading noticeably different indicates trouble at that point.

*b.* A partial short on a B+ line will cause overheating of some associated part and eventually the part will become defective. To check for trouble of this kind, check the resistance from pin 3 of V5 to B—; it should be 1500 ohms. Figure 23 shows the B+ voltage distribution in the receiver. Use this diagram with the voltage and resistance chart.

*c.* Coupling capacitors between stages can become leaky and produce a high resistance short which places a positive voltage on the grid of the following tube. Disconnect one lead of each capacitor and check for leakage, using the highest resistance scale of the ohmmeter.

*d.* Improper avc action can be caused by a short in one of the bypass capacitors C4, C10, or C44 (fig. 40). A defective 1U4 r-f tube V1, 1L6 converter tube V2, or 1U4 i-f tube V3 also can be the cause. Figure 22 shows the circuit of the avc distribution.

*e.* Voltage checks should be made on both power line and battery operation.

## 67. Operational Test

*a.* Operate the equipment as described in the equipment performance checklist (par. 41). This checklist is important because it frequently indicates the general location of trouble. Listen for background noise in the receiver or for received signals.

*b.* Check the on-off switch and volume control for positive action and smooth control of volume.

*c.* Try the tuning control for smoothness without slippage.

*d.* Check the band selector buttons for positive action.

*e.* Extend the whip antenna and operate the receiver on all bands to check for signal pick-up.

*f.* Correct avc action can be checked on strong signals. No overloading or distortion should occur.

*g.* No microphonism should occur on a strong signal with the volume control set at average output level.

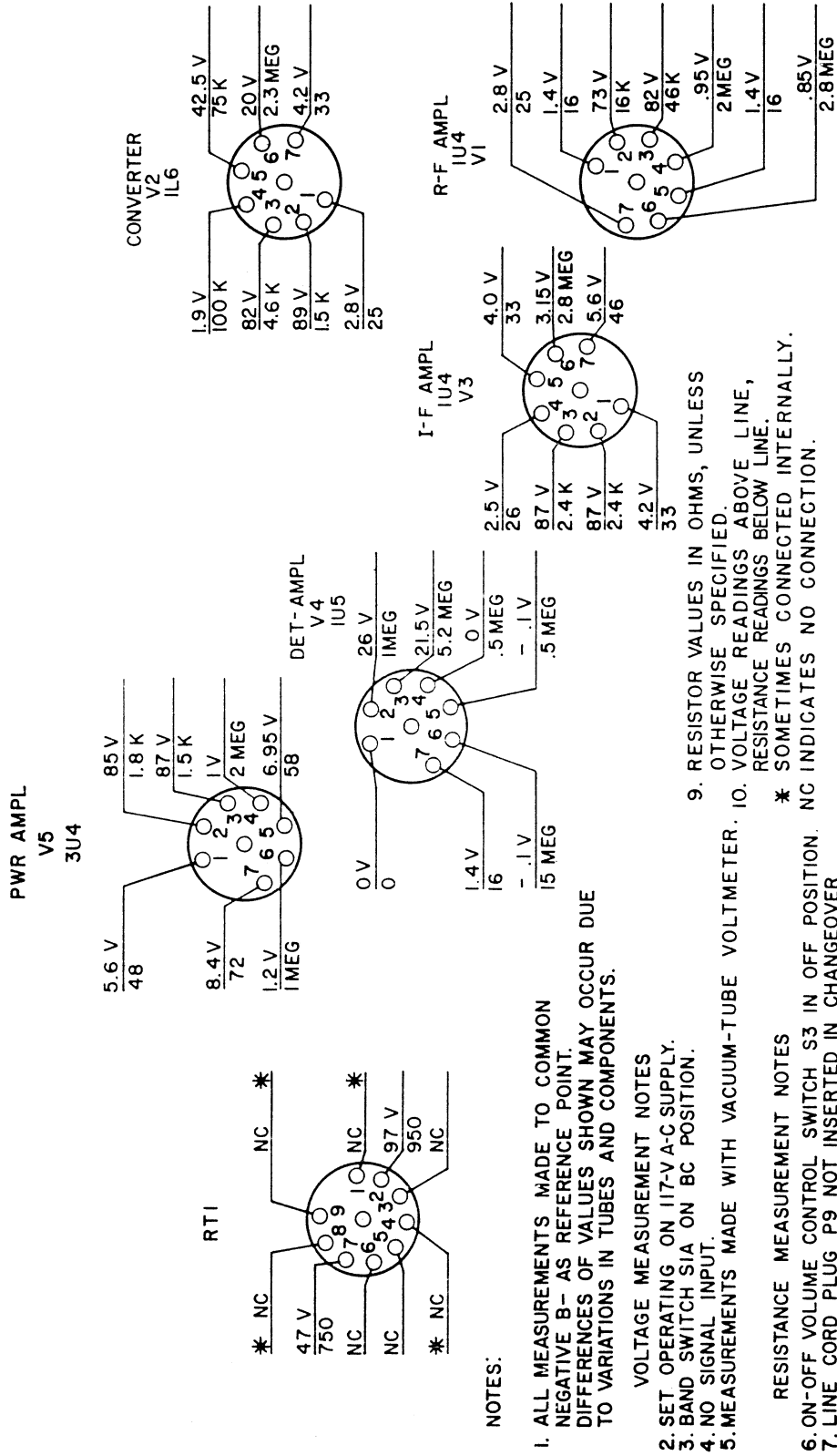

**NOTES:**

1. ALL MEASUREMENTS MADE TO COMMON NEGATIVE B- AS REFERENCE POINT. DIFFERENCES OF VALUES SHOWN MAY OCCUR DUE TO VARIATIONS IN TUBES AND COMPONENTS.
  2. SET OPERATING ON I17-V-A-C SUPPLY.
  3. BAND SWITCH S1A ON BC POSITION.
  4. NO SIGNAL INPUT.
  5. MEASUREMENTS MADE WITH VACUUM-TUBE VOLTMETER.
- VOLTAGE MEASUREMENT NOTES**
9. RESISTOR VALUES IN OHMS, UNLESS OTHERWISE SPECIFIED.
  10. VOLTAGE READINGS ABOVE LINE, RESISTANCE READINGS BELOW LINE. \* SOMETIMES CONNECTED INTERNALLY. NC INDICATES NO CONNECTION.
- RESISTANCE MEASUREMENT NOTES**
6. ON-OFF VOLUME CONTROL SWITCH S3 IN OFF POSITION.
  7. LINE CORD PLUG P9 NOT INSERTED IN CHANGE-OVER SWITCH S4.
  8. LINE CORD PLUG P9 NOT CONNECTED TO POWER SOURCE.

Figure 27. Voltage and resistance diagram.



h. Using a frequency meter, the calibration should be checked on all bands.

i. Finally, tap or jar the set to make certain no loose connections exist.

### 68. Trouble-shooting Charts

The following charts are supplied as an aid in locating trouble in the receiver. These charts list the symptoms which the operator or repairman may observe, either visually or audibly, while making a few simple tests. *The charts also indicate how to sectionalize trouble quickly to the particular stage or circuit.* The signal substitution tests outlined in paragraphs 70 through 73 then can be used to supplement this procedure and to determine the defective circuit. A tube check and voltage and resistance measurement of the defective circuit ordinarily should be sufficient to isolate the defective part.

*Note.* In the following tests, the power is turned on, and the receiver is operative. Set the receiver controls as in the preparatory section of the equipment performance checklist (par. 41).

#### a. SECTIONALIZING TROUBLE.

Symptom	Probable trouble	Correction
1. Receiver inoperative on battery operation only. Neon light on dial scale glows.	Weak A batteries.	Replace A batteries.
2. Receiver inoperative on battery only. Neon light on dial scale does not glow.	B batteries dead.	Replace B batteries.
3. Receiver operative on battery and line voltage. Neon dial light indicator does not glow on <i>Battery</i> , but lights up on <i>Line Voltage</i> operation.	Weak B batteries.	Replace B batteries.
4. Receiver inoperative on power line.	Fuse, F1, open.	Replace fuse.
5. Motor boats on broadcast band.	V <sub>3</sub> 1U4 i-f tube defective.	Replace tube.
	V <sub>1</sub> 1U4 r-f tube defective.	Replace tube.
6. Microphonic distortion on broadcast band.	V <sub>4</sub> , 1U5 detector-amplifier tube defective.	Replace tube.
7. Distorted output on broadcast band.	V <sub>4</sub> , 1U5 detector-amplifier tube defective.	Replace tube.

b. LOCALIZING TROUBLE.

Symptom	Probable trouble	Correction
1. Low frequency end of broadcast band cuts out, no signals.	Oscillator coil L2 defective.	Replace coil.
2. No signal on power line operation.	CR1 or CR2 selenium rectifier defective. Poor contact on ballast adapter socket J2.	Replace rectifier. Reset contact on J2 socket.
3. Weak audio.	Coupling capacitor C24 partially shorted. Grid bias resistor R18 has low value resistance.	Replace capacitor. Replace resistor.
4. No audio from speaker.	Headset jack J3 open.	Reset contacts.
5. Hum with volume control turned down.	Filter capacitors C45A, C45B, C45C open or defective.	Replace filter.
6. Slight hum with volume control turned up.	C21 audio grid blocking capacitor defective.	Replace capacitor.
7. Noise in speaker when operating band selector buttons.	Dirty contacts on band selector switch.	Clean contacts with carbon tetrachloride. See <i>Caution</i> , paragraph 31.
8. Weak audio.	Tone control resistor R32 has low resistance.	Replace resistor.
9. Weak signals on all bands, using power line operation.	Filter capacitors C45A, C45B, C45C defective; B+ voltage low.	Replace filter capacitor.
10. Signals weak on broadcast band.	Converter grid coupling capacitor C7 open.	Replace capacitor.
11. Image signals on broadcast band.	Avc bypass capacitor C4 open.	Replace capacitor.
12. No signals on 4-8 mc. band.	Band selector contacts defective.	Set contacts for positive action.
13. No signals at 7.9 mc.	Capacitor C39 open. Trimmer capacitor C40A shorted. Coupling capacitor C37 open .	Replace capacitor. Replace capacitor. Replace capacitor.

b. LOCALIZING TROUBLE (contd).

Symptom	Probable trouble	Correction
14. Receiver breaks into oscillation at 7.9 mc.	Converter tube 1L6 defective. Filament bypass capacitor C9 open. Defective band selector switch contacts. H-f oscillator capacitor C12 shorted.	Replace tube. Replace capacitor. Set band selector contacts . Replace capacitor.
15. Signal shifts frequency when the receiver is jarred.	Lead wire to oscillator section C 2 E of ganged capacitor close to ganged capacitor frame.	Dress wire away from capacitor frame and coils. Re-align set.
16. Tone control buttons break off.	Receiver chassis not tightened to cabinet.	Tighten the chassis mounting screws.
17. Receiver noise present on broadcast band when loop antenna is swung up into position over cabinet or when jarred.	Rivet pin or pins of front cover hinge bracket assembly unsoldered, or solder connection broken.	Resolder rivet pins to mounting bracket (fig. 33).
18. Signals weak at 3.9 mc or 7.8 mc.	Plate coupling capacitor C6 open or high resistance leakage.	Replace capacitor.
19. No signals on 16 M band.	Oscillator coil L2 open.	Replace coil.
20. No signals on 16, 19, 25, and 31 M spread bands.	Defective contacts on band selector. Oscillator coil L2 has shorted turns. Coupling capacitor C37 open. Coupling capacitor C38 open or high leakage resistance. Coupling capacitor C42 open or high leakage resistance.	Reset for positive action. Replace coil. Replace defective capacitor.
21. Set dead or off calibration at 3.9 mc.	Capacitor C41 open. Oscillator coil L2 has shorted turns.	Replace capacitor. Replace coil.
22. All short-wave bands weak using whip antenna.	Telescopic whip antenna capacitor C27 open.	Replace capacitor.

b. LOCALIZING TROUBLE (contd).

Symptom	Probable trouble	Correction
23. Signals weak at 3.9 mc.	R-f trimmer capacitor C35B shorted.	Replace defective capacitor.
24. Signals weak on 16, 19, 25, and 31 M spread bands.	Whip antenna capacitor C27 open. Coupling capacitor C34 open. Coupling capacitor C33 open.	Replace defective capacitor.
<p><i>Note.</i> For steps 25 through 38, refer to General Signal Substitution notes, paragraph 70.</p>		
25. No resonance at 3.9 mc for r-f trimmer capacitor C35B.	Trimmer capacitor C35B shorted. Band selector switch has defective contacts.	Replace trimmer capacitor. Set band selector contacts for positive action.
26. No resonance at 7.9 mc for r-f trimmer capacitor C35A.	Trimmer capacitor C35A shorted. Band selector switch has defective contacts.	Replace trimmer capacitor. Set contacts for positive action.
27. R-f trimmers C35A, C35B, broad peak.	Coupling capacitor C34 open.	Replace capacitor.
28. Broad peak at 17.8 mc, 15.2 mc, 11.8 mc, and 9.6 mc.	Coupling capacitor C36 open. Coupling capacitor C38 open.	Replace defective capacitor.
29. Broadcast band does not calibrate and signals are weak.	Three section ganged capacitors C2A, C2C, C2E mounting screw shorting to capacitor stator.	Set capacitor mounting screw for clearance.
30. No 455-kc resonance for i-f transformer T1 secondary.	Resistor R14 has too low a value. Capacitor C44 open or has high resistance short. Open secondary winding on T1.	Replace resistor. Replace capacitor. Replace transformer.
31. No resonance for converter trimmer C2D at 1420 kc.	Converter coil L1 open.	Replace coil.
32. No resonance at 3.9-mc for antenna trimmer C31A.	Antenna coil L5 open.	Replace coil.
33. No resonance for loop antenna trimmer C2B at 1500 kc.	Antenna loading coil L4 open.	Replace coil.
34. No resonance for broadcast loop antenna trimmer C2B.	Capacitor C30 too close to metal chassis. Lead wires from the loop antenna to loop receptacle are too close to the chassis.	Dress capacitor and lead wires away from the chassis.

**b. LOCALIZING TROUBLE (contd).**

Symptom	Probable trouble	Correction
35. No resonance for broadcast r-f trimmer C2D.	Signal grid lead wire to pin No. 6 of 1L6 converter tube is too close to metal chassis.	Dress the wire away from the chassis.
36. Broadcast band does not calibrate.	Oscillator coil L2 has shorted turns.	Replace coil.
37. No resonance on antenna or r-f coils on 16, 19, 25, or 31 M spread bands.	Band selector switch has defective contacts.	Reset contacts.
38. Oscillator coil L20 does not resonate at 17.8 mc.	Lead wire from oscillator coil L20 to pin No. 3 of 1L6 converter tube is too close to the chassis.	Dress the lead wire away from the metal chassis.

**69. D-c Resistance of Transformers and Coils**

The d-c resistance of the transformers and coils are listed below:

Transformer or coil	Terminals or winding	Resistance (ohms)
L1 converter grid coil.	AB	8
	CD	6.1
L2 oscillator coil.	AC	.013
	BD	8.2
	EF	3.2
	HG	.7
L3 r-f choke coil.		23
T1 i-f transformer.	1-8	25
	4-5	25
T2 i-f transformer.	1-8	25
	6-7	25
T3	Primary winding.	280
	Voice coil winding.	3
	Inverse feedback winding.	13
E2	Broadcast loop.	.7

**70. General Signal Substitution Notes**

*a.* Signal substitution requires a source of audio, i-f, and r-f signals. If available, use an isolation transformer between the power line and the receiver.

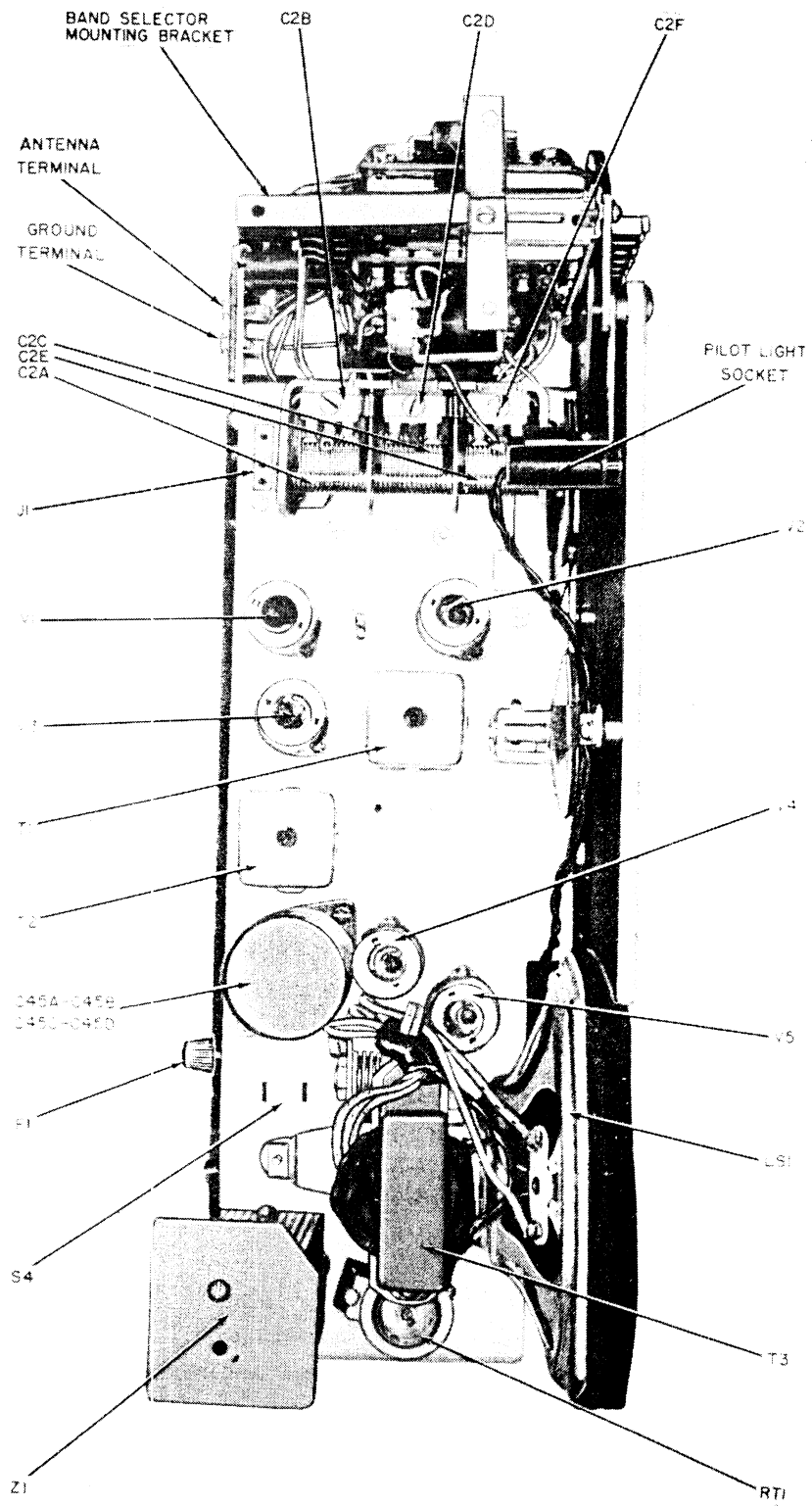

TM877-28

Figure 28. Top view of chassis.

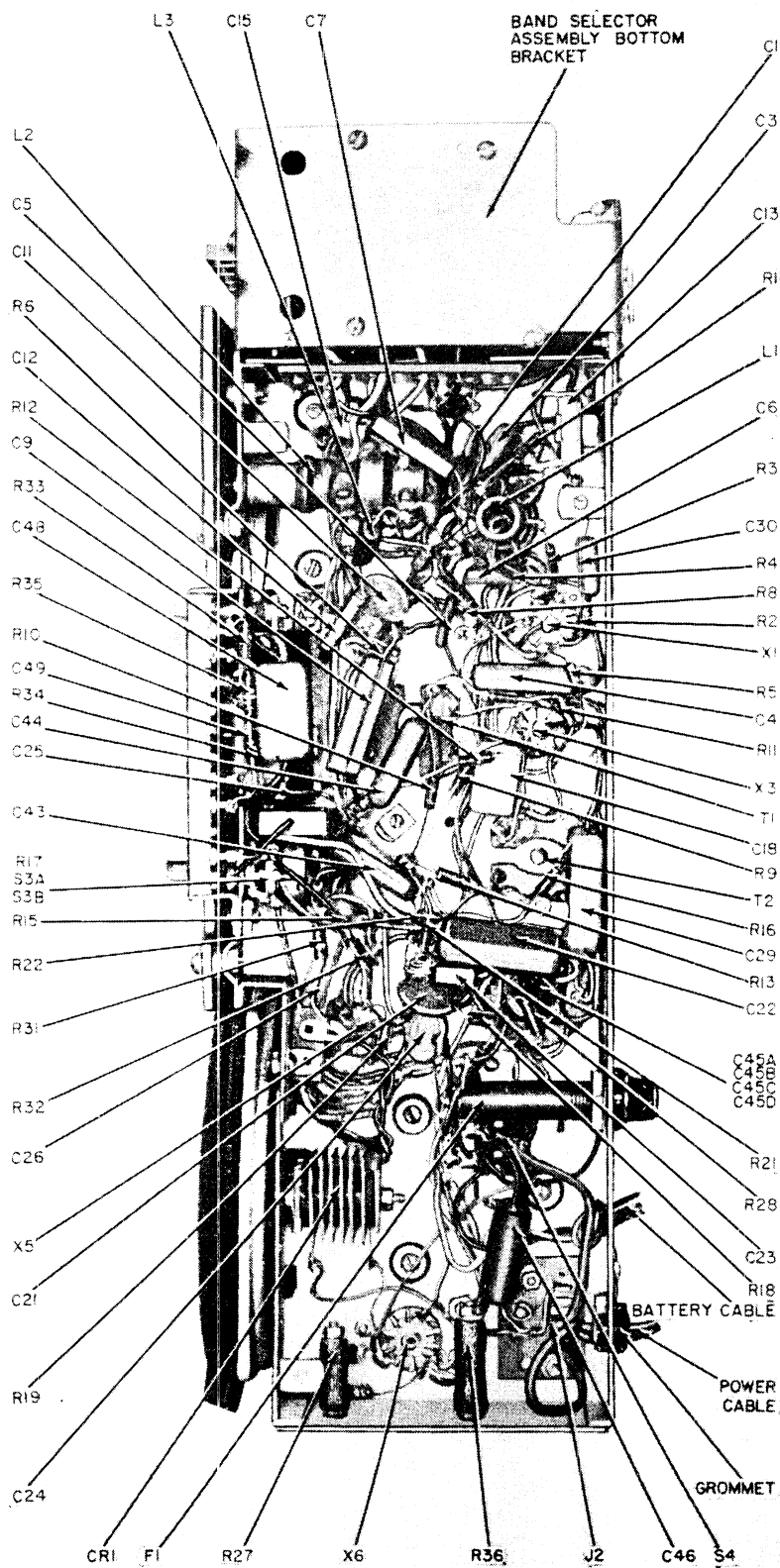

TMB77-29

Figure 29. Bottom view of chassis.

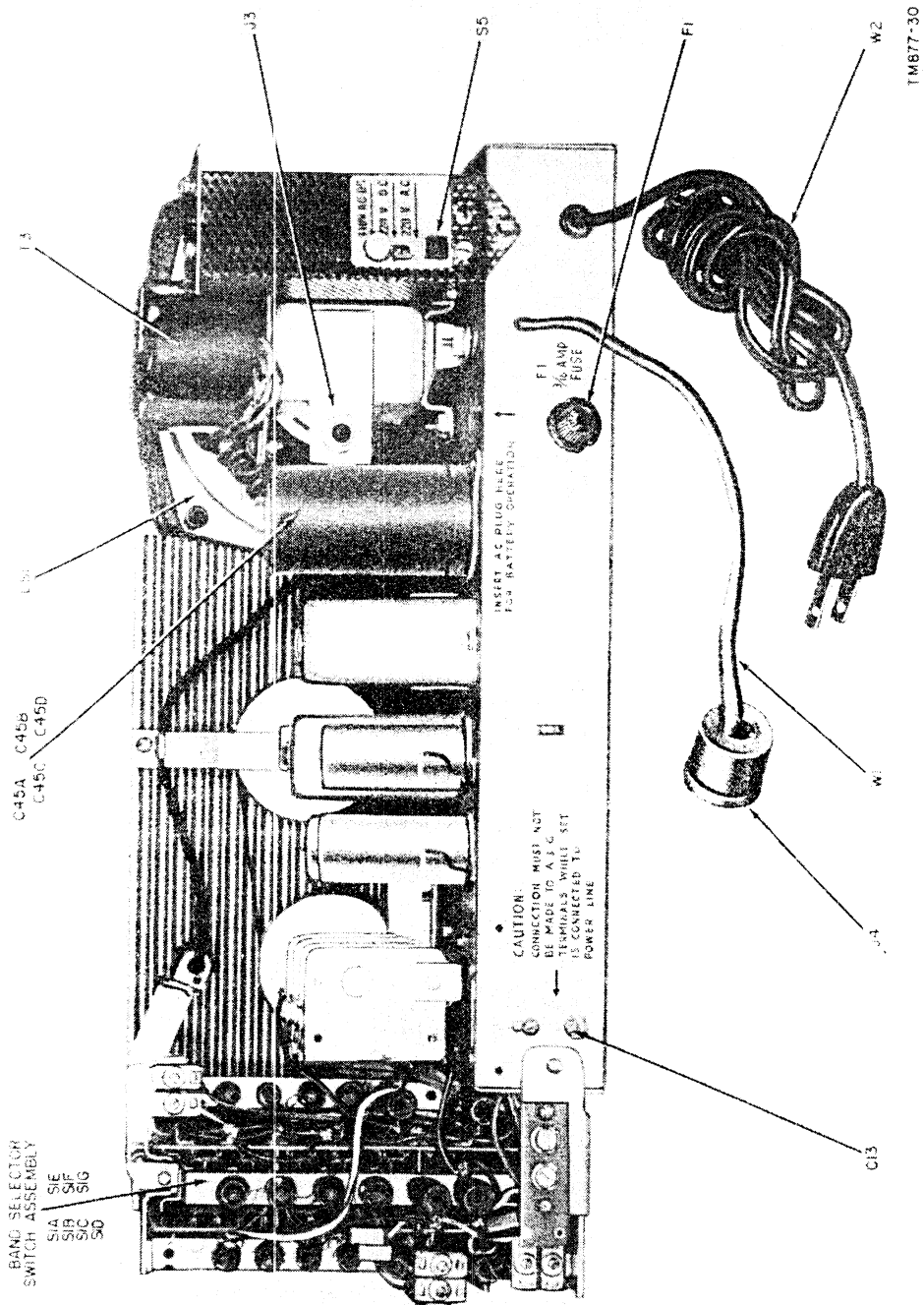

Figure 30. Rear view of chassis.



b. Note the volume, and listen for serious distortion from the loudspeaker or headset at the various points in the signal substitution procedure. Where possible, compare operation with a receiver known to be in good condition.

c. Check the wiring and soldering in each stage during the procedure.

*Note.* Do not remove r-f and i-f shields from the chassis, or shield cans from the tuned units, until the trouble has been traced definitely to the particular unit. Do not damage wiring by pushing it back and forth during inspection. Be careful not to damage the receiver in any other way.

d. Misalignment of one or more stages of the receiver will cause reduced output. Misalignment of the h-f oscillator may prevent any output.

e. When trouble is localized in a given stage, test the tube, measure the voltage, and measure the resistance at the tube socket of that stage (fig. 27).

f. Trouble in a circuit or stage may not cause changes in voltages and resistance measurements at the tube socket. The notes included in this paragraph are merely a guide and should suggest other procedures, such as voltage and resistance measurements on individual parts.

g. Remove only one tube at a time when testing. Check the type number of the tube and test the tube. If the tube is not defective, return it to its proper socket before another tube is removed.

h. Each step assumes the satisfactory completion of all previous steps. Isolate and clear any trouble located before proceeding with any succeeding steps.

#### **71. A-f Signal Substitution Tests**

Under normal conditions, with the volume control set to its maximum clockwise position, 25 mv (millivolt) of audio signal fed to the center lug of the volume control will deliver approximately 50 mw (milliwatt) of power to a 3-ohm resistive load connected across the audio-output transformer secondary. Output Meter TS-585/U or equal, set for a 3-ohm load, may be connected to headset jack J3 by means of Plug PL-55. (The speaker voice coil is disconnected automatically.) The shielded or ground lead of the audio signal

generator output cable should be connected to the B— bus of the receiver; for example: the negative lug of filter capacitor C45A, C45B, C45C, C45D, or the negative filament (pin 1) of the 1U5 detector-amplifier tube.

*a.* Apply a 25-mv, 1000-cycle sine wave audio signal from the audio generator through a .05-uf capacitor to the center lug of volume control potentiometer R17 and turn the control to its maximum clockwise position. A high volume audio signal should come from the speaker or, if an output meter is used connected for a 3-ohm load, it should read 50 mw (.4 volts ac). If there is no audio or the audio output is low, check the speaker, output transformer, headset jack, tubes V4 and V5, and the capacitors and resistors in the associated audio circuit.

*b.* Weak audio or audio with distortion or hum can be localized further by feeding the audio signal first to the signal grid (pin 6) of V5 and then to the center lug on the volume control (volume control on full) and comparing the two outputs. Approximately 50 times as much audio power should be developed with the volume control connection as compared with the signal grid connection of V5 with the same signal level from the audio generator.

## **72. I-f and Converter Signal Substitution Tests**

*a.* Adjust the signal generator to 455 kc with 400-cycle 30-percent modulation applied. Apply this signal in series with a .1 uf (microfarad) capacitor to the signal grid (pin 6) of the 1U4 i-f tube V3. Connect the shield or ground lead of the signal generator cable to the B— bus and set the volume control to its maximum clockwise position. Set the band selector to BC.

*b.* Connect an output meter with Plug PL-55 into headset jack J3. With a 3000 uv (microvolt) signal fed to the signal grid (pin 6) of V3 approximately 50 mw should be developed at the output.

*c.* Gain through a stage can be recognized by connecting the generator output to the signal grid, then to the plate of the same tube. The output level should be higher at the grid connection.

*d.* If there is no signal or a weak signal when the signal generator is connected to the signal grid (pin 6) of V3, i-f transformer T2 may have a shorted or open winding. Capacitor C20A, or C19 may be shorted, the transformer may be misaligned, or tube V3 may be defective.

e. If the output is normal for a signal applied to the signal grid (pin 6) of V3, connect the signal generator output lead to pin 6 of the 1L6 converter tube, V2. With the signal generator output set for 100 uv, with 400-cycle 30-percent modulation, approximately 50 mw of power should be developed across a 3-ohm resistive load.

f. If there is no signal or it is weak, T1 may have a shorted or open winding. Capacitor C16 or C17 may be shorted, the transformer may be misaligned, or tube V2 may be defective.

### 73. R-f Signal Substitution Tests

Check the r-f stage for proper operation by connecting the signal generator output lead with 400-cycle 30-percent modulation, to pin 6 of the 1U4 r-f tube V1. The following sensitivities should be measured for 50 mw into a 3-ohm load. Any deviation from the values listed below indicates misalignment or a defective component.

Band	Input voltage (uv)
Broadcast	15 to 30
2-4 mc	40 to 70
4-8 mc	40 to 70
Spread bands	30 to 75

### 74. Antenna Stage Test

Since a loop type antenna, whip antenna, and provisions for a long wire antenna are incorporated in Radio Receiver R-520/URR, antenna sensitivity will vary considerably, depending on conditions used in the measurements. Check loop antenna E2 and whip antenna E1 for shorts and open connections.

### 75. H-f Oscillator Test

Check the h-f oscillator for proper action by connecting a vacuum-tube voltmeter from the oscillator grid (pin 4) of the 1L6 converter tube to the negative filament (pin 1). The following voltages should be read :

Band	H-f oscillator grid voltage
Broadcast band	-4 to -9 v
2-4 mc	-3 to -5 v
4-8 mc	-3 to -7 v
Spread bands	-2 to -4 v

## 76. Stage Gain and Sensitivity Chart

*a.* When checking stage gain or sensitivity, observe the following points:

- (1) If available, use an isolation transformer between the power line and the receiver.
- (2) The dummy antenna for external antenna operation consists of a 400-ohm resistor in series with a 200-uuf (micro-microfarad) capacitor.
- (3) The dummy antenna for short wave operation consists of a 20-uuf capacitor. Disconnect the whip antenna and connect the 20-uuf capacitor to the whip antenna tip jack (fig. 26).
- (4) When using the external antenna or whip antenna dummy connections, connect the ground lead of the signal generator to the ground terminal of the receiver.
- (5) When checking the r-f amplifier, connect the signal generator output to the grid of the r-f amplifier through a .1-uf blocking capacitor. Connect the ground lead of the signal generator to the B— bus of the receiver.
- (6) The dummy antenna for broadcast operation is a standard RMA (Radio Manufacturers Association) test loop (par. 95). Do not ground the signal generator output cable to the receiver when using the RMA test loop.

*b.* The chart below lists the average input voltages required at each of the r-f and i-f stages of the receiver to produce a signal output of 50 mw which is equivalent to .4 volts ac across a 3-ohm resistive load. Use this chart as a standard when troubleshooting to check the over-all gain of the receiver and the gain of each stage, or group of stages. When checking the sensitivity of the receiver on the broadcast band, locate the test loop and the receiver loop  $19\frac{3}{4}$  inches apart on centers, and parallel to each other. Under these conditions the field intensity at the receiver loop in uv/M will be one-tenth the signal generator output voltage. When the receiver output is low, localize the defective stage by

checking the signal voltage level of each stage against the chart while using either the signal tracing method of trouble shooting or by measuring the individual stage gain.

Band	Test frequency (mc) (modulated 30 percent at 400 cycles)	Av. sensitivity (input required for 50 mw output)			
		R-F amplifier grid (pin 6 of V1) (uv)	Loop antenna (uv/M)	Whip antenna (uv)	External antenna (uv)
Broadcast	.6	20	65		65
	1.5	20	50		50
2-4 mc	2.1	35		11	20
	3.9	40		5	20
4-8 mc	4.2	35		9	20
	7.8	50		3	20
31 M	9.6	20		3	15
25 M	11.8	20		4	25
19 M	15.2	30		4	30
16 M	17.8	25		6	40

c. The following chart lists the approximate gain for each circuit in the receiver. For example, the gain of the r-f stage is measured as follows: Measure the signal generator voltage required at pin 6 of V2 to produce 50-mw output across the 3-ohm load. Measure the signal generator voltage required at pin 6 of V1 to produce the same output. Divide the first reading (the larger one) by the second reading to determine the stage gain. When making stage gain measurements, be sure to connect the ground lead of the signal generator to the B- bus.

Stage	Test point	Test frequency (modulated 30 percent at 400 cycles)	Input	Average stage gain
R-f amplifier	Pin 6 of V1	600 kc	20 uv	5
Converter	Pin 6 of V2	455 kc	100 uv	30
I-f amplifier	Pin 6 of V3	455 kc	3000 uv	28
Det-amplifier	Pin 6 of V4	400 cps	25 mv	65
Audio output	Pin 6 of V5	400 cps	1.6 volts	14

## Section II. REPAIRS

### 77. Replacement of Parts

Most of the parts in Radio Receiver R-520/URR are readily accessible and easily replaceable. Figure 29 shows the location of parts beneath the chassis.

*a.* When the band selector switch assembly requires replacement, mark the wires connected to the switch carefully with tags or other devices to avoid errors in connections when the new switch is installed. Refer to figure 31.

*b.* Figure 32 shows the dial cord system on Radio Receiver R-520/URR. Two dial cords are used; one for the dial tuning shaft and the other for the pointer pulley. To replace the dial cord for the pointer pulley, it is necessary to remove the dial scale. The tuning shaft dial cord can be strung without removing the dial scale. When it is replaced, the cord should be strung around the tuning shaft first.

### **78. Front Cover Hinge Repair**

The two hinge bracket assemblies on the front cover are part of the electrical circuit that connects the loop antenna on the door to the receiver (fig. 33). A loose or broken solder connection on the rivet pin or broken wire will create electrical interference or intermittent operation on the broadcast band. To repair, proceed as follows:

- a.* Disconnect the loop antenna cable plug from the set.
- b.* Remove the volume control knob and the tuning control knob.
- c.* Remove the receiver chassis and batteries from the cabinet (par. 64).
- d.* Remove all front panel screws which secure the panel to the cabinet and remove the front panel.
- e.* Remove both screws that hold the handle to the top of the cabinet and remove the handle.
- f.* Take out the five wood screws that hold the top panel to the cabinet and remove the panel.
- g.* Remove the four wood screws that hold both mounting brackets to the top of the cabinet and remove the top cover with the hinge assembly from the rest of the cabinet.
- h.* Resolder the broken solder connection of rivet pin to mounting bracket and reassemble in the reverse order.

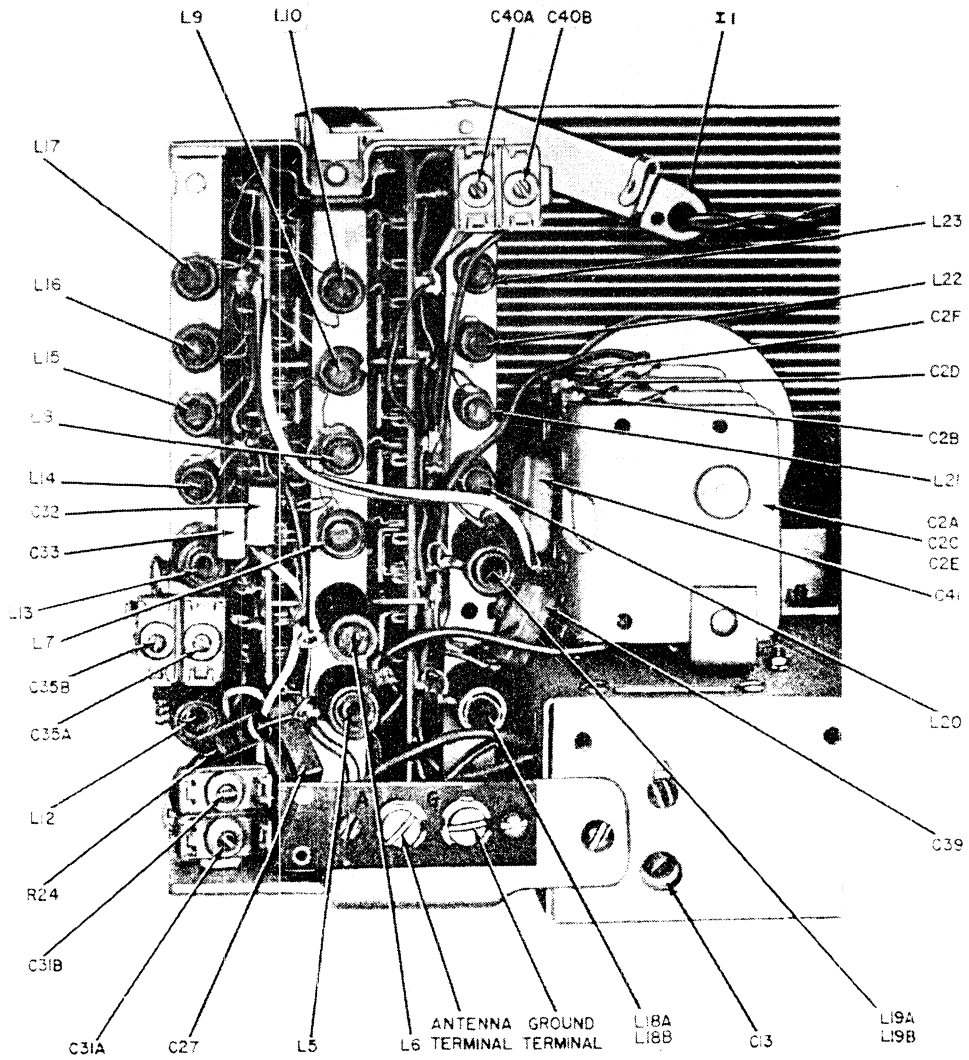

TM877-33

Figure 31. Band selector switch, rear view.

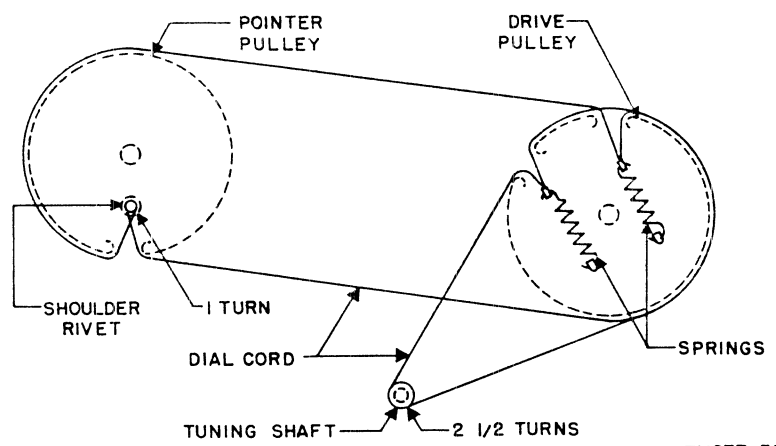

TM877-32

Figure 32. Dial cord drive system.

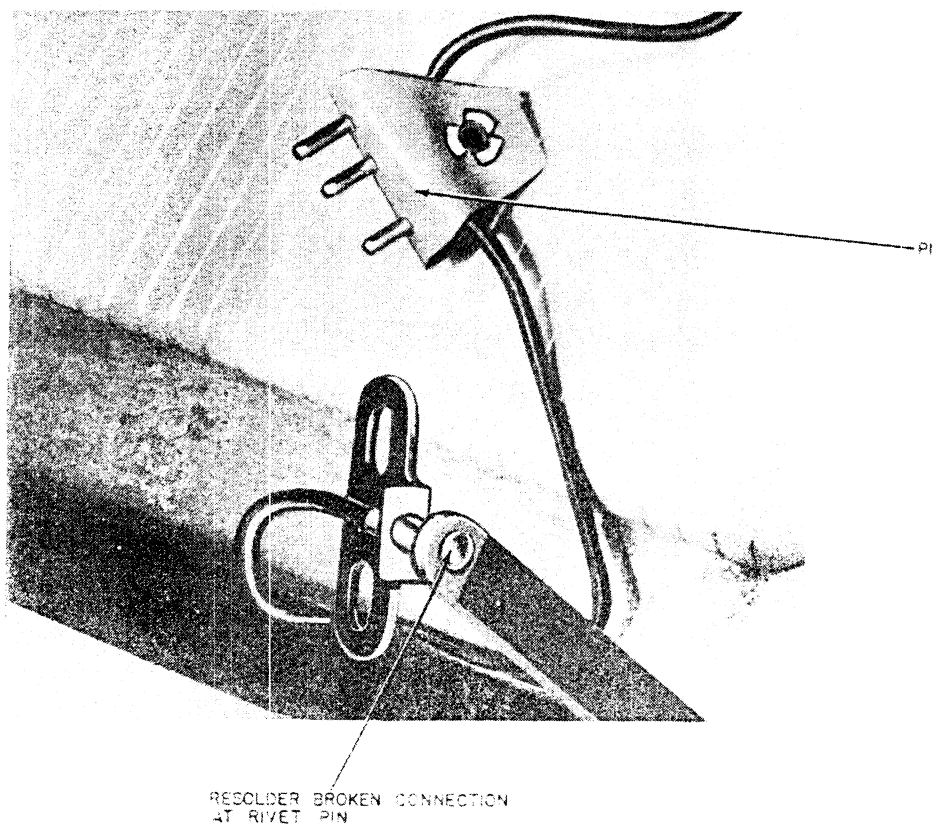

Figure 33. Front cover hinge assembly repair.

TM877-31

### 79. Refinishing

Instruction for refinishing badly marred cabinets are given in paragraph 37.

## Section III. ALINEMENT PROCEDURES

### 80. Test Equipment Required for Alinement

a. SIGNAL GENERATOR. The signal generator must be an accurately calibrated instrument capable of producing modulated and unmodulated r-f signals, such as RF Signal Generator Set AN/URM-25. The frequency range must extend from 400 kc to 25 mc. The alinement frequencies are shown in the alinement chart. If necessary, the second harmonic generally can be used when the fundamental is not available. Thus, a signal generator with a top frequency of 12.5 mc also is suitable. The generator should have an output of at least 5,000 uv for best results in alining the r-f, h-f oscillator, and i-f circuits. Frequency calibration of



the signal generator is extremely important to insure that the receiver dial calibration will be correct.

b. **OUTPUT METER.** The output meter should respond to audio frequencies and should provide readings at 50 mw and have a maximum range of 500 mw. For correct readings, the impedance of the meter must match the 3-ohm voice coil winding. Use Output Meter TS-585/U (or equivalent), set for a 3-ohm load.

c. **FREQUENCY METER.** When a highly accurate signal generator is not available, a frequency meter can be used to check the accuracy of the generator. Frequency Meter Set BC-221-(\*) is suitable for this purpose.

d. **HEADSET OR PERMANENT MAGNET LOUDSPEAKER.** The receiver loudspeaker or a headset can be used for rough alinement.

e. **ALINEMENT TOOLS.** The alinement tool, O 14, supplied with the receiver and an insulated screw driver are required.

*Caution:* Alinement tool O 14 is intended for alinement of the i-f and r-f transformers. *Do not attempt to use it for turning trimmer capacitors or as a screw driver.*

### **81. Calibration of Signal Generator**

The procedure below is used only when the signal generator calibration is not acceptable.

a. Accurate alinement of the h-f oscillator in the receiver requires the use of the frequency meter to check the signal generator setting, as follows:

- (1) Place the generator and frequency meter near each other. Turn them on and allow them to warm up for at least 15 minutes.
- (2) Calibrate the frequency meter according to the instructions furnished with the unit.
- (3) Attach a piece of wire to the signal generator output connection and place the wire near the frequency meter antenna.
- (4) Set the meter to the exact frequency to which the generator is to be used.

- (5) While listening to the headset connected to the frequency meter, tune the generator to zero beat with the meter. The signal generator now is set for the frequency desired.

- b. Turn off the frequency meter and remove the wire attached to the signal generator output connection.

## 82. Preparation for Alinement

- a. Remove the chassis from the cabinet in accordance with instructions in paragraph 64.

- b. If available, use an isolation transformer between the power line and the receiver.

- c. Make certain the power supply adapter switch is in the correct position to conform to the power source that is available.

- d. Connect the power cord to the external power line source. Turn the receiver on and let it warm up for 5 minutes.

- (1) Turn the volume control to its maximum clockwise position.
- (2) Set the receiver for broadcast operation.
- (3) Connect a 3-ohm output meter to Plug PL-55 and insert it into jack J3.
- (4) Aline the various sections of the receiver in the following order :

I-f stage.

Broadcast Band.

4-8 mc continuous coverage band.

2-4 mc continuous coverage band.

31 M band.

25 M band.

19 M band.

16 M band.

*Note.* With the signal generator modulated 30 percent at 400 cycles, the final sensitivity measurements are taken at standard output of 50 mw across a 3-ohm load.

### 83. I-f Alinement Procedure (fig. 28)

a. Adjust the i-f transformer cores with the alinement wrench, O 14, supplied with the receiver. This wrench should be inserted through the hole in the top of the can to adjust the top core of the transformer, then lowered through the top core to adjust the bottom core. Be careful when alining these transformers that the cores are entering the coil windings from the top and bottom of the coil forms. If this is not done, it is possible to advance the top core beyond, and the bottom core above, its associated coil. This would result in an incorrect coefficient of coupling, unstable, and improper alinement.

*Note.* Alinement wrench O 14 is a special purpose tool designed primarily for adjusting the i-f and r-f transformers. *Do not use the alinement wrench as a screw driver or to turn trimmer capacitors.*

b. Press the BC band selector switch.

c. Set the signal generator to 455 kc, modulated 30 percent at 400 cycles, and connect its output through a .1-uf blocking capacitor to the 1L6 converter signal grid (pin 6). The stator terminal of capacitor C2C is a convenient point for this connection. Do not set the signal generator output any higher than is necessary to provide a usable reading on the output meter (about 50 mw). Connect the ground lead of the signal generator output cable to the B— bus of the receiver.

d. With the alinement wrench, adjust the top and bottom cores of i-f transformer, T2, for maximum output indication on the output meter.

e. Adjust the top and bottom cores of transformer T1 for maximum output indication on the output meter.

f. Readjust all i-f cores.

### 84. Broadcast Band Alinement

a. Couple the signal generator output lead through a .1-uf blocking capacitor to the grid (pin 6) of r-f amplifier tube V1. Leave the ground lead of the signal generator connected to the B— bus of the receiver.

b. Set the signal generator to 1,500 kc modulated 30 percent at 400 cycles.

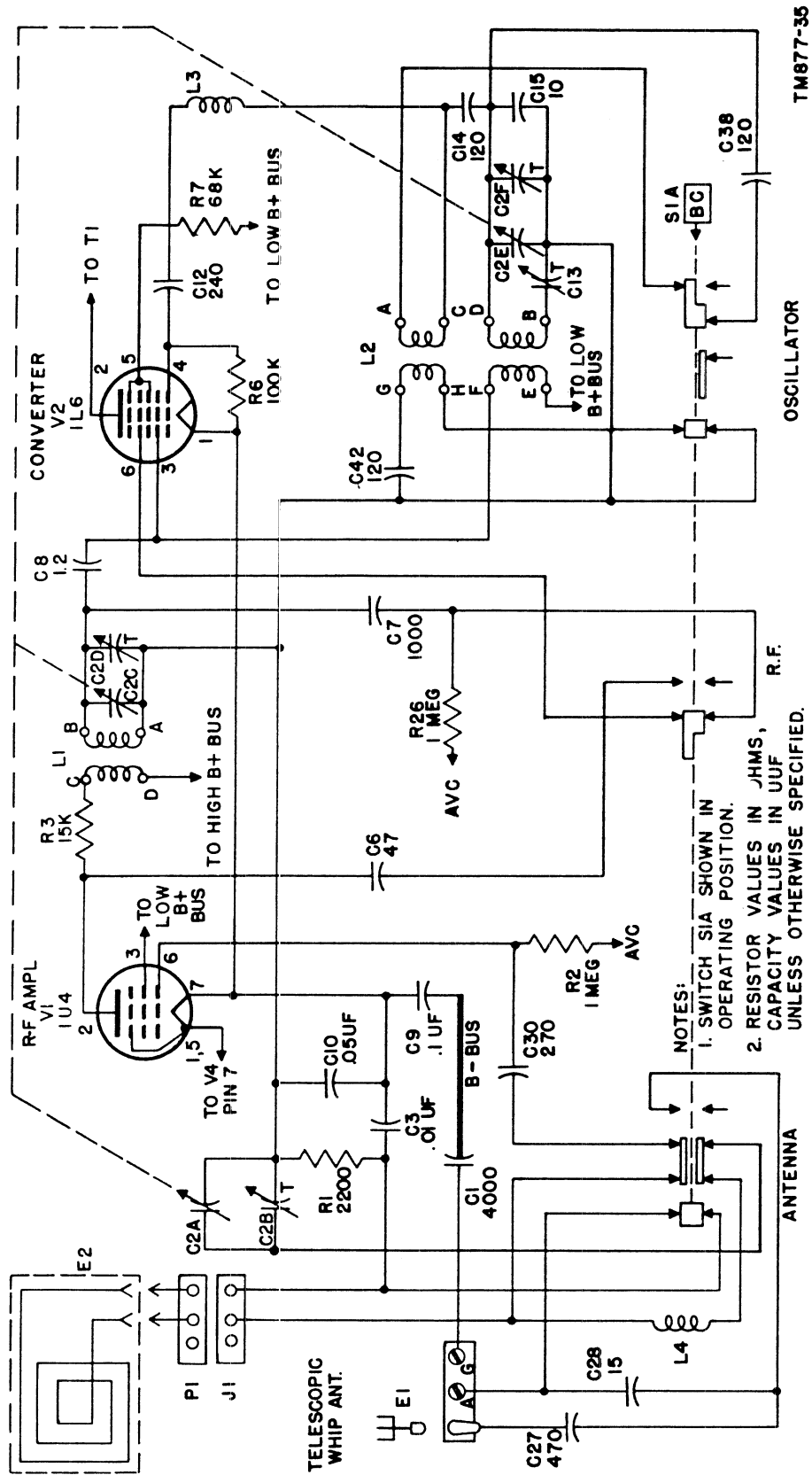

Figure 3.1. Band selector switch shown in BC position.

*c.* Press the BC band selector switch.

*d.* With the ganged tuning capacitor completely meshed (low frequency end), mechanically set the dial pointer horizontally across the dial scale.

*e.* Turn the tuning control so that the dial pointer is set to 150 on the broadcast scale.

*f.* Adjust oscillator trimmer capacitor C2F (fig. 28) for resonance at 1,500 kc. Do not set the signal generator output any higher than is necessary.

*g.* Adjust r-f trimmer capacitor C2D (fig. 28) for maximum output indication on the output meter.

*h.* Set the signal generator to 600 kc modulated 30 percent at 400 cycles.

*i.* Turn the tuning control so that the dial pointer is set to 60 on the broadcast scale.

*j.* Rock the ganged tuning capacitor while adjusting broadcast padder capacitor C13 (fig. 30) for maximum output indication on the output meter.

*k.* Repeat the operations outlined in subparagraphs *f*, *g*, and *j* above.

*l.* Repeat operations in subparagraphs *f* and *g* above.

*m.* Figure 34, which shows the switch connections for broadcast operation, is shown for reference purposes.

#### **85. 4- 8-mc Band Alinement Procedure (fig. 31)**

*a.* Set the signal generator to 7.8 mc modulated 30 percent at 400 cycles.

*b.* Disconnect the whip antenna and connect the signal generator output lead in series with a 20-uuf capacitor to the whip antenna tip jack. Connect the ground lead of the signal generator to ground terminal G.

*c.* Press the band selector switch marked: 4-8 MC.



d. Turn the tuning control so that the dial pointer is set to 7.8 mc on the 4- 8-mc scale.

e. Adjust oscillator trimmer capacitor C40A for resonance at 7.8 mc.

*Note.* C40A has two resonant points. The correct one is near the maximum capacity of the trimmer. The second point is the image frequency and care must be taken to avoid selecting the image.

f. Adjust r-f trimmer C35A and antenna trimmer C31A for maximum output indication on the output meter.

g. Set the signal generator to 4.2 mc modulated 30 percent at 400 cycles.

h. Turn the tuning control so that the dial pointer is set to 4.2 mc on the 4- 8-mc scale.

*Note.* There may be two resonant points on the short-wave coils in Radio Receiver R-520/URR. The correct setting for the oscillator coil cores is the one which is farthest from the open end of the coil. Images are created when the core of the oscillator coil on a short-wave band is set to the wrong peak. It is very important that the core be set correctly. The correct resonant point for all other coil cores is the peak nearest the open end of the coil.

i. Adjust the core of oscillator coil L18A, L18B for resonance at 4.2 mc while rocking the ganged tuning capacitor.

j. Adjust the core of r-f coil L12 and antenna coil L5 for maximum indication on the output meter.

k. Repeat the operations outlined in subparagraphs e, f, i, and j above.

l. Repeat operations in subparagraphs e and f above.

m. Figure 35, which shows the switch connections for 4-8-mc operation, is shown above for reference purposes.

#### **86. 2- 4-mc Band Alinement Procedure (fig. 31)**

a. Using the same connections outlined in paragraph 85, set the signal generator to 3.9 mc, modulated 30 percent at 400 cycles.

b. Press the band selector switch marked : 2-4 MC.

*c.* Turn the tuning control dial so that the pointer is set to 3.9 mc on the 2- 4-mc scale.

*d.* Adjust oscillator trimmer capacitor C40B for resonance at 3.9 mc. This is the resonant point nearest maximum trimmer capacity.

*e.* Adjust r-f trimmer capacitor C35B and antenna trimmer C31B for maximum indication on the output meter.

*f.* Turn the tuning control so that the dial pointer is set to 2.1 mc on the 2- 4-mc scale.

*g.* Set the signal generator to 2.1 mc, modulated 30 percent at 400 cycles.

*h.* Adjust the core of oscillator coil L19 for resonance at 2.1 mc while rocking the ganged tuning capacitor.

*i.* Adjust the core of r-f coil L13 and antenna coil L6 for maximum indication on the output meter.

*j.* Repeat the operations outlined in subparagraphs *d*, *e*, *h*, and *i* above.

*k.* Repeat the operations outlined in subparagraphs *d* and *e* above.

#### **87. 31 M Band Alinement Procedure (fig. 31)**

*a.* Using the same connections outlined in paragraph 85, set the signal generator to 9.6 mc, modulated 30 percent at 400 cycles.

*b.* Press the 31 M band selector switch (9.4-9.8 mc).

*c.* Turn the tuning control dial so that the pointer is set to 9.6 mc on the 31 M scale.

*d.* Adjust the core of oscillator coil L23 for resonance at 9.6 mc.

*e.* Adjust the core of r-f coil L17 and antenna coil L10 for maximum indication on the output meter.



#### **88. 25 M Band Alinement Procedure (fig. 31)**

*a.* Using the same connections outlined in paragraph 85, set the signal generator to 11.8 mc, modulated 30 percent at 400 cycles.

*b.* Press the 25 M band selector switch (11.6-12.0 Mc).

*c.* Turn the tuning control so that the dial pointer is set to 11.8 mc on the 25 M scale.

*d.* Adjust the core of oscillator coil L22 for resonance at 11.8 mc.

*e.* Adjust the core of r-f coil L16 and antenna coil L10 for maximum indication on the output meter.

#### **89. 19 M Band Alinement Procedure**

*a.* Using the same connections outlined in paragraph 85, set the signal generator to 15.2 mc, modulated 30 percent at 400 cycles.

*b.* Press the 19 M band selector switch (14.9-15.5 mc).

*c.* Turn the tuning control so that the receiver dial pointer is set to 15.2 mc on the 19 M scale.

*d.* Adjust the core of oscillator coil L21 for resonance at 15.2 mc.

*e.* Adjust the core of r-f coil L15 and antenna coil L8 for maximum indication on the output meter.

#### **90. 16 M Band Alinement Procedure (fig. 31)**

*a.* Using the same connections outlined in paragraph 85, set the signal generator at 17.8 mc, modulated 30 percent at 400 cycles.

*b.* Press the 16 M band selector switch (17.8-18.1 Mc).

*c.* Turn the tuning control so that the dial pointer is set to 17.8 mc on the 16 M scale.

*d.* Adjust the core of oscillator coil L20 for resonance at 17.8 mc.

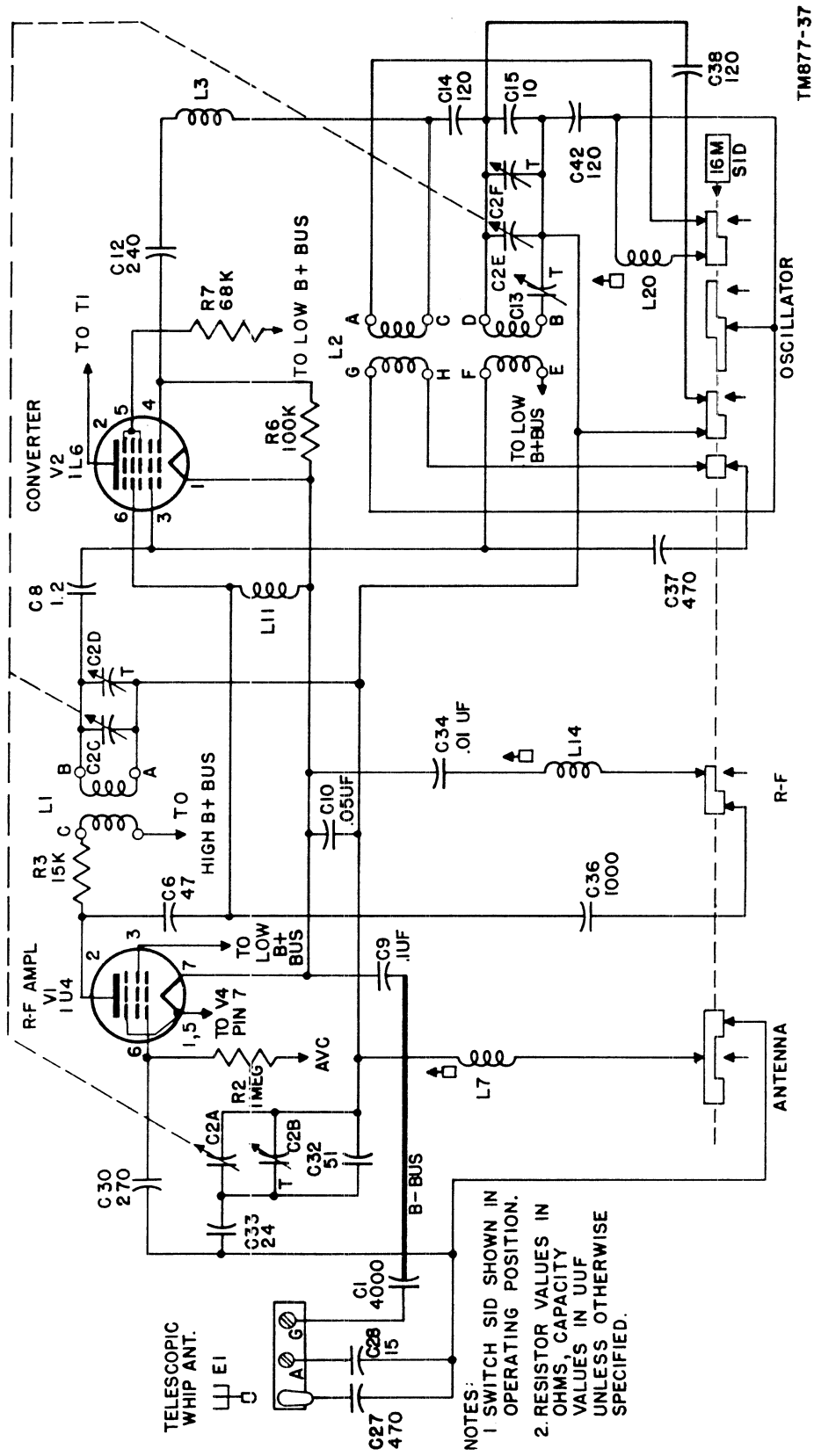

TM877-37

Figure 36. Band selector switch shown in 16 M position.

*e.* Adjust the core of r-f coil L14 and antenna coil L7 for maximum indication on the output meter.

*f.* Figure 36, which shows the switch connections for 16 M operation, is shown for reference purposes.

### **91. Chassis Installation**

Install the chassis in the cabinet. Reverse the procedure outlined in paragraph 64, but do not install protective cover A 3 (fig. 4) until after final adjustments are made (par. 92).

### **92. Final adjustments**

The following adjustments are made with the signal generator modulated 30 percent at 400 cycles.

#### *a.* BROADCAST BAND.

- (1) Loop a turn of wire from the signal generator output lead around broadcast loop antenna E2.
- (2) With the signal generator and receiver set to 1,500 kc, adjust antenna trimmer capacitor C2B for maximum output indication on the output meter (fig. 28).
- (3) With the signal generator and receiver set to 600 kc, rock the ganged tuning capacitor while adjusting C13 for maximum output indication on the output meter (fig. 30).
- (4) Repeat operation described in subparagraph (2) above.

#### *b.* 4- 8-MC BAND.

- (1) Connect the signal generator output lead to an antenna 3 feet long and place it at a distance of approximately 1 foot from extended whip antenna E1.
- (2) With the signal generator and receiver set to 7.8 mc, adjust antenna trimmer capacitor C31A

for maximum output as indicated on the output meter (fig. 31).

- (3) With the signal generator and receiver set to 4.2 mc, adjust antenna tuning coil L5 for maximum output as indicated on the output meter (fig. 31).
- (4) Repeat the operation described in subparagraph (2) above.

*c.* 2- 4 MC BAND. Following the same general procedure as in subparagraph *b* above, adjust antenna trimmer capacitor C31B at 3.9 mc and antenna tuning coil L6 at 2.1 mc (fig. 31).

*d.* 31 METER BAND. Following the same general procedure as in subparagraph *b* above, adjust antenna tuning coil L10 at 9.6 mc (fig. 31).

*e.* 25 METER BAND. Following the same general procedure as in subparagraph *b* above, adjust antenna tuning coil L9 at 11.8 mc (fig. 31).

*f.* 19 METER BAND. Following the same general procedure as in subparagraph *b* above, adjust antenna tuning coil L8 at 15.2 mc (fig. 31).

*g.* 16 METER BAND. Following the same general procedure as in subparagraph *b* above, adjust antenna tuning coil L7 at 17.8 mc (fig. 31).

*h.* PROTECTIVE COVER. Install protective cover A3 (par. 64).

### 93. Alinement Chart

The alinement chart below is included as a reference guide. Specific alinement instructions are given in section III of this chapter.

### 93. Alignment Chart

Oper	Connection	Input Signal Freq (30% modulated at 400 cycles)	Band	Set dial at	Adjust	Purpose
1	Output lead of signal generator to converter grid through a .1 uf capacitor and ground lead to B-bus.	455 kc	BC	600 kc	T2 top and bottom T1 top and bottom	I-f alinement
2	Couple generator output lead to r-f grid (pin 6) of V1.	1500 kc	BC	1500 kc	C2F	Oscillator alinement
3		1500 kc	BC	1500 kc	C2D	R-f alinement
4		600 kc	BC	Rock at 600 kc	C13	Oscillator pad-der alinement
5		Repeat operations 2, 3, and 4				
6		Repeat operations 2 and 3				
7	Couple generator output lead through a 20 uuf capacitor to whip antenna tip jack. Connect ground lead to terminal post G.	7.8 mc	4-8 MC	7.8 mc	C40A C35A C31A	Oscillator, r-f and antenna alinement
8		4.2 mc	4-8 MC	Rock at 4.2 mc	L18 L12 L5	

98 93. Alignment Chart (contd)

Oper	Connection	Input Signal Freq (30% modulated at 400 cycles)	Band	Set dial at	Adjust	Purpose
9		Repeat operations 7 and 8				
10		Repeat operation 7				
11		3.9 mc	2-4 MC	3.9 mc	C40B C35B C31B	
12		2.1 mc	2-4 MC	Rock at 2.1 mc	L19 L13 L6	
13		Repeat operations 11 and 12				
14		Repeat operation 11				
15		9.6 mc	31 M	9.6 mc	L23 L17 L10	
16		11.8 mc	25 M	11.8 mc	L22 L16 L9	
17		15.2 mc	19 M	15.2 mc	L21 L15 L8	
18		17.8 mc	16 M	17.8 mc	L20 L14 L7	

Replace chassis in cabinet. Reconnect whip antenna tip lead and insert loop antenna plug into loop antenna socket.						
	One turn loop coupled loosely to broadcast loop antenna.	1,500 kc	BC	1,500 kc	C2B	Alinement of BC antenna loop
19						
20						
21	Connect generator output lead to 3 feet of wire approximately 1 foot from whip antenna.	7.8 mc 4.2 mc	4-8 mc	7.8 mc 4.2 mc	C31A L5	
22		3.9 mc 2.1 mc	2-4 mc	3.9 mc 2.1 mc	C31B L6	Alinement of antenna
23		9.6 mc	31 M	9.6 mc	L10	
24		11.8 mc	25 M	11.8 mc	L9	
25		15.2 mc	19 M	15.2 mc	L8	
26		17.8 mc	16 M	17.8 mc	L7	

Note: Rock tuning capacitor when making alinement under operations 4, 8, 12, 15, 16, 17, and 18.

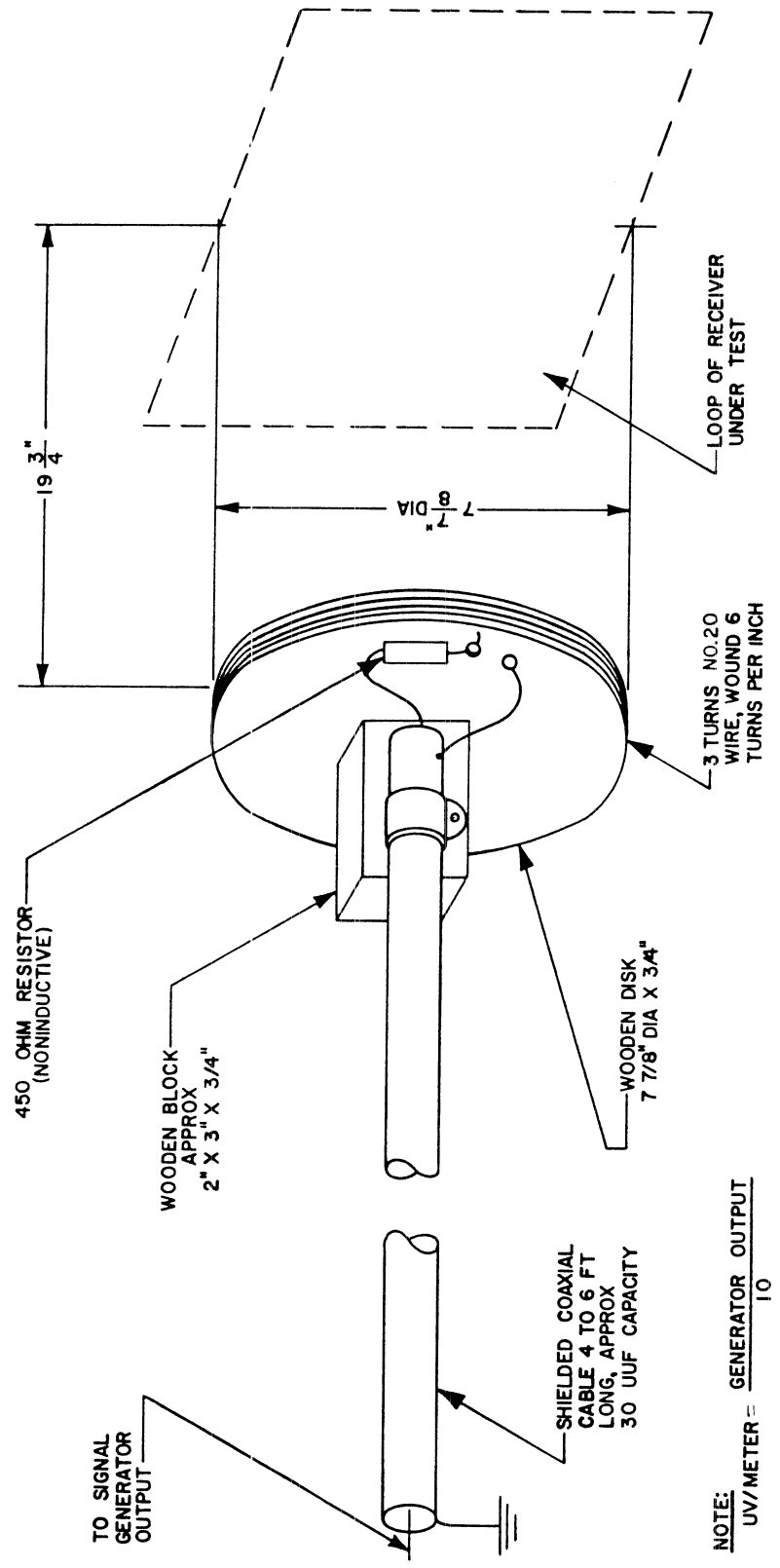

TM877-34

Figure 37. RMA test loop setup.



## Section IV. FINAL TESTING

### 94. General

*a.* This section is intended as a guide to be used in determining the quality of a repaired Radio Receiver R-520/URR. The minimum test requirements outlined in paragraph 96 through 101 may be performed by maintenance personnel with adequate test equipment and the necessary skills. Repaired equipment meeting these requirements will furnish uniformly satisfactory operation.

*b.* The receiver should be operated from both an external power line source and batteries. Allow the receiver to warm up for a few minutes and make all measurements with a line voltage of 117 volts a-c.

### 95. Test Equipment Required for Final Testing

*a.* The equipment needed for testing the repaired receiver is listed in paragraph 62. In addition, a standard RMA test loop and a standard audio signal generator equivalent to the Hewlett-Packard model 200B are required.

*b.* If an RMA test loop is not available, a suitable substitute may be fabricated as follows (fig. 37).

- (1) Wrap 3 turns of No. 20 wire on a  $7\frac{7}{8}$ -inch diameter form, spaced 3 turns per half inch.
- (2) Solder a 450-ohm non-inductive resistor in series with the high side of the loop.
- (3) Solder the center conductor of a 4-foot length of shielded cable to the free end of the 450-ohm resistor, and the outer conductor to the low side of the loop. (The capacitance of the shielded cable should be 30 uuf for the 4-foot length.)

### 96. Operation of Controls

A complete check of the operation of the receiver controls should be made in accordance with the equipment performance checklist (par. 41).

### 97. Sensitivity

The over-all sensitivity of the receiver should correspond to the readings in paragraph 76.

### 98. Selectivity

Connect the shielded cable of the RMA test loop to the r-f signal generator (center conductor to the high side of the generator, outer conductor to the low side). Locate the test loop and the receiver loop  $19\frac{3}{4}$  inches apart on centers, and parallel to each other. Under these conditions the field intensity at the receiver loop in uv/M will be one-tenth the signal generator output voltage. Set the signal generator to 930 kc, modulated 30 percent at 400 cycles and connect a 3-ohm output meter to headset jack J3. Adjust the signal level for 50 mw at the output of the receiver. Increase the signal generator output to twice (6 db) (decibels) its original setting. Detune the signal generator first above and then below 930 kc until the receiver output again is 50 mw. The difference between the high and low generator dial setting should be approximately 6.38 kc. Repeat for signal generator outputs of 10 times and 100 times the original settings. The bandwidths should approximate those shown in the following chart:

Ratio of input voltage off resonance to voltage at resonance	Average bandwidth (kc)
1 (0-db) (reference)	—
2 (6-db attenuation)	6.38
10 (20-db attenuation)	15.32
100 (40-db attenuation)	27.94

### 99. Image Ratio Check

a. To check the image ratio on the broadcast band, couple the standard RMA test loop as close as possible to loop antenna E2.

b. To check the image ratio on the short-wave bands, disconnect the whip antenna lead from the tip jack and couple the signal generator output lead to the jack through a 20-uuf capacitor. Connect the ground lead of the generator output cable to the receiver ground terminal.

c. The image ratios for Radio Receiver R-520/URR are listed in the following chart:

99c. (contd)

Band	Signal frequency (mc)	Image frequency (mc)	Image rejection ratio	db
BC	.6	1.51	5000	74
BC	.930	1.84	1000	60
BC	1.5	2.41	300	49
2-4 MC	2.1	3.01	400	52
2-4 MC	3.9	4.81	55	35
4-8 MC	4.2	5.11	350	50
4-8 MC	7.8	8.71	30	30
31 M	9.6	8.69	25	28
25 M	11.8	10.89	15	24
19 M	15.2	14.29	10	20
16 M	17.8	16.89	5	14

100. Audio Response

a. Connect a standard audio signal generator equivalent to the Hewlett-Packard model 200B to the r-f signal generator. Set the r-f signal generator to external modulation and connect the output lead through a .1 uf capacitor to the r-f grid, (pin 6) of V1. Connect the ground leads of the audio and r-f signal generators to the B— line of the receiver.

b. Viewing the front of the receiver, set the TREBLE, VOICE, and BASS tone control buttons to the right and the ALTO button to the left.

c. Set the r-f signal generator to 930 kc and the audio generator to 400 cycles and tune the receiver to 930 kc. Vary the modulating frequency from the audio signal generator and check the audio response as follows (0 db as the reference point at 400 cycles) :

*Note.* Keep the modulation level at 30% for all readings.

Audio response	Frequency (cps)
0 db (reference)	400
+1.0 db to —4 db	100
—6.0 db to —23.0 db	3500

### 101. Avc and Power Output

a. Set the r-f signal generator and receiver to 930 kc and connect the output cable of the generator through a .1 uf capacitor to the r-f grid, pin 6 of V1. Modulate the r-f signal generator 30 percent at 400 cycles and connect the ground lead of the generator output cable to the B— line of the receiver. The output should read as follows:

Input	Output (mw)
50 uv	220 to 350
.1 volt	290 to 370

b. If the output is below the values in the chart, the audio may be weak, or r-f overloading may be occurring. Check the i-f and r-f tubes and capacitors associated with the avc circuit.

## CHAPTER 6

# SHIPMENT AND LIMITED STORAGE AND DEMOLITION TO PREVENT ENEMY USE

---

### Section I. SHIPMENT AND LIMITED STORAGE

#### 102. General

Since the circumstances involved in shipment and storage vary, no definite procedure for repacking can be given. The exact procedure depends on the material available and the conditions under which the equipment is to be stored or shipped. If available, use the carton in which the unit was packed originally.

#### 103. Repacking for Shipment or Limited Storage (fig. 2)

- a.* Make certain the whip antenna is collapsed and locked in position.
- b.* If a headset is used, box or package it in a separate carton.
- c.* Roll up the power line cord and tuck it in the receiver near the speaker so it will clear the rear cover of the cabinet when closed. Insert the plug in the power change-over switch socket S4 on the top of the chassis to prevent the plug from causing damage to the interior of the receiver during shipment.
- d.* Remove all batteries but do not remove battery case E23. Place the red harness, W4, and the black harness, W6, in the cloth bag and stow the bag in the battery compartment of the receiver.

e. Make certain the four adapter plugs are in place on the bracket underneath the receiver case top panel.

f. Whenever practicable, place a dehydrating agent, such as silica gel inside the receiver. Wrap the unit in corrugated paper and protect each package with a waterproof barrier. Seal the seams of the paper barrier with a waterproof sealing compound or tape. Pack the protected components in a wooden case, providing at least 3 inches of excelsior padding or other similar material between the paper barrier and the packing case.

## **Section II. DEMOLITION OF MATERIEL TO PREVENT ENEMY USE**

### **104. General**

The demolition procedures outlined in paragraph 105 will be used to prevent the enemy from using or salvaging this equipment. Demolition of the equipment will be accomplished only upon order of the commander.

### **105. Methods of Destruction**

a. *Smash.* Smash the controls, tubes, switches, capacitors, and transformers, using sledges, axes, handaxes, pickaxes, hammers, crowbars, or heavy tools.

b. *Cut.* Cut internal and external wires and cables using axes, handaxes, or machetes.

c. *Burn.* Burn cords, resistors, capacitors, wiring and instruction books using gasoline, kerosene, oil, flame throwers, or incendiary grenades.

d. *Bend.* Bend panels and chassis.

e. *Explosives.* If explosives are necessary, use firearms, grenades, or TNT.

f. *Disposal.* Bury or scatter the destroyed parts in slit trenches, fox holes, or other holes, or throw them into streams.

g. *Destroy.* DESTROY EVERYTHING.

# APPENDIX I

## REFERENCES

*Note.* For availability of items listed, check SR 310-20-3, SR 310-20-4, and SR 310-20-5. Check Department of the Army Supply Catalog SIG 1 for Signal Corps Supply Catalog pamphlets.

---

### 1. Army Regulations

- |          |                                                                                          |
|----------|------------------------------------------------------------------------------------------|
| AR 380-5 | Military Security (Safeguarding Military Information).                                   |
| AR 750-5 | Maintenance of Supplies and Equipment (Maintenance Responsibilities and Shop Operation). |

### 2. Supply Bulletins

- |          |                                                                             |
|----------|-----------------------------------------------------------------------------|
| SB 11-6  | Dry Battery Supply Data.                                                    |
| SB 11-47 | Preparation and Submission of Requisitions for Signal Corps Supplies.       |
| SB 11-76 | Signal Corps Kit and Materials for Moisture- and Fungi-Resistant Treatment. |

### 3. Auxiliary Equipment and Test Equipment

- |            |                                                                                                                  |
|------------|------------------------------------------------------------------------------------------------------------------|
| TM 11-300  | Frequency Meter Sets SCR-211-A, B, C, D, E, F, J, K, L, M, N, O, P, Q, R, T, AA, AC, AE, AF, AG, AH, AJ, AK, AL. |
| TM 11-307  | Signal Generators I-72-G, H, J, K, and L.                                                                        |
| TM 11-472  | Repair and Calibration of Electrical Measuring Instruments.                                                      |
| TM 11-2627 | Tube Tester I-177 and I-177-A.                                                                                   |

TM 11-2684A	Audio Oscillator TS-382A/U.
TM 11-5017	Output Meter TS-585A/U and TS-585B/U.
TM 11-5500	Multimeter TS-297/U.
TM 11-5018	Signal Generator TS-588/U (when published).
TM 11-5511	Electronic Multimeter TS-505/U.
TM 11-5527	Multimeter TS-352/U.
Navships 91283	RF Signal Generator Set AN/URM-25.

**4. Painting, Preserving, and Lubrication**

TB SIG 13	Moistureproofing and Fungiproofing Signal Corps Equipment.
TB SIG 69	Lubrication of Ground Signal Equipment.
TM 9-2851	Painting Instructions for Field Use.

**5. Camouflage, Decontamination, and Demolition**

FM 5-20	Camouflage, Basic Principles.
FM 5-25	Explosives and Demolitions.
TM 3-220	Decontamination.

**6. Other Publications**

FM 24-18	Field Radio Techniques.
FM 72-20	Jungle Warfare.
SR 310-20-3	Index of Training Publications.
SR 310-20-4	Index of Technical Manuals, Technical Regulations, Technical Bulletins, Supply Bulletins, Lubrication Orders, Modification Work Orders, Tables of Organization and Equipment, Reduction Tables, Tables of Allowances, Table of Organization, and Tables of Equipment.
SR 310-20-5	Index of Administrative Publications.
SR 700-45-5	Unsatisfactory Equipment Report (Reports Control Symbol CSGLD-247).
SR 745-45-5	Report of Damaged or Improper Shipment (Reports Control Symbols CSGLD-66 (Army), SandA-70-6 (Navy), and AF-MC-U2 (Air Force)).
NAV DEPT SERIAL 85P00	
AFR 71-4	



TB SIG 4	Methods for Improving the Effectiveness of Jungle Radio Communication.
TB SIG 25	Preventive Maintenance of Power Cords.
TB SIG 66	Winter Maintenance of Signal Equipment.
TB SIG 72	Tropical Maintenance of Ground Signal Equipment.
TB SIG 75	Desert Maintenance of Ground Signal Equipment.
TB SIG 123	Preventive Maintenance Practices for Ground Signal Equipment.
TB SIG 219	Operation of Signal Equipment at Low Temperatures.
TB SIG 223	Field Expedients for Wire and Radio.
TB 11-499- ( ) <sup>1</sup>	Basic Radio Propagation Predictions.
TM 9-2857	Storage Batteries Lead-Acid Type.
TM 11-314	Antennas and Antenna Systems.
TM 11-415	Dry Batteries.
TM 11-430	Batteries for Signal Communication. Except those pertaining to Aircraft.
TM 11-453	Shop Work.
TM 11-455	Radio Fundamentals.
TM 11-466	Radar Electronic Fundamentals.
TM 11-476	Radio Direction Finding.
TM 11-483	Suppression of Radio Noises.
TM 11-486	Electrical Communication Systems Engineering.
TM 11-496	Training Text and Applicatory Exercises for Amplitude-Modulated Radio Sets.
TM 11-499	(Preliminary), Radio Propagation Handbook.
TM 11-660	Introduction to Electronics.
TM 11-661	Electrical Fundamentals (Direct Current).
TM 11-681	Electrical Fundamentals (Alternating Current).
TM 11-4000	Trouble Shooting and Repair of Radio Equipment.

---

<sup>1</sup>A new TB in this series is issued monthly which gives propagation predictions 3 months in advance.

## APPENDIX II

### IDENTIFICATION TABLE OF PARTS

---

#### 1. Requisitioning Parts

The fact that a part is listed in this table is not sufficient basis for requisitioning the item. Requisitions must cite an authorized basis, such as a specific T/O&E, T/E, T/A, T/BA, SIG 6, SIG 7&8, SIG 7-8-10, SIG 10, list of allowances of expendable material, or another authorized supply basis. The Department of the Army Supply Catalog applicable to the equipment covered in this manual is SIG 7&8 R-520/URR. For an index of available supply catalogs in the Signal portion of the Department of the Army Supply Catalog, see the latest issue of SIG 1, Introduction and Index.

2. Identification Table of Parts for Radio Receiver R-520/URR

Ref. symbol	Name of part and description	Function of Part	Signal Corps stock No.
	<p>RECEIVER, radio: A3 reception; 540- to 18,200-kc range, 7 bands; 117 v and 230 v, 60 cyc ac, single ph, 10 w and 20 w; 117 v and 230 v dc, 65 ma; 6 ea "A" batteries, 3 ea "B" batteries, "A" battery 1.5 v, "B" battery 90 v; "A" Battery BA-30/U, "B" Battery BA-270/U; 17-5/16" lg x 11-1/16" h x 7-31/32" d; 5 tubes superheterodyne circuit; voltage adapter, cur regulator, removable loop ant, loop extension cable, telescopic whip ant, ext batt cable, spare tubes, fuses, glow lamp, tuning wrench, line cord adapter kit; Zenithrad.</p>		2CH180-520
Z1	<p>ADAPTER, power supply: 1 input, male plug type, on bottom; 1 output male plug type, on bottom; steel case; black finish; 1-3/8" sq 4-1/4" lg; female socket mtd; plug pol; adapts rec to 220 v ac and dc oper by means of built-in slide switch; switch cover marked from top to bottom 110 v ac-dc, 220 v dc and 220 v ac; Zenithrad part/dwg No. SG6615.</p>	<p>Adapts receiver to 220 v ac or dc.</p>	3H5Z
E1	<p>ANTENNA: whip type; 2 to 18 mc freq range, 725 ohms at 10 mc, stranded cond feed; telescopic construction, element, 8 sect., extended lg 60-1/2", collapsed lg 9-15/16"; brass, gray chrome, except stationary sec. cad pl w/clear iridite finish; mtd by ins clamp; equipped w/brown tenite knob and spring release assem attached to top sect.; Ward Prod; part No. G-SPP-208; Zenithrad part/dwg No. SG6621.</p>	<p>Receiving antenna, 2-18 mc.</p>	2A288B-21

## 2. Identification Table of Parts for Radio Receiver R-520/URR (contd)

Ref. symbol	Name of part and description	Function of Part	Signal Corps stock No.
E2	ANTENNA: loop; pancake type; 540 to 1600 kc freq range, high impedance input, open line feed; array construction; one element; 12" x 5" fixed type, cased in polystyrene; 2 longitudinal spaced holes secure ant inclosure to cabinet front door, provide electrical connections for receiving a signal. Leads run to two cabinet hinges conductive to 2-wire cables and plug assem inside cabinet; can be re-motely mtd by utilizing suction cup assem and ant extension cable; Zenithrad part/dwg No. SG6624.	Receiving antenna for broad-cast band.	2A288B-22
H3	SCREW, thumb; brass finished; round knurled head; 7/16" h x 5/16" w; 4-40 thd, class 2 fit; 7/8" nom lg; Zenithrad part/dwg No. 112G3021.	Position lock for voltage adapter switch.	6L17104-14.8K
A 7	BRACKET, fastener: steel; cad pl w/clear iridite; 1" lg x 9/32" h; used as fastener for back door cabinet latch; 1 hole, screw mtd; Amer Cabt Hdwe part No. 3675A.	Fastener for back door latch.	2Z1244-321
O 52 thru O 57	BUSHING, mounting: steel; cad pl w/clear iridite; flange dim; 3/8" dia, 1/32" thk; shank diam: 1/95 dia, 7/32" lg; .145" dia hole; Cinch part No. 8359; Zenithrad part/dwg No. 94G3090.	0 52 thru 54: Tuning capacitor mounting bushings. 0 55 thru 0 57: Speaker mounting bushings.	2Z1409-385
W1	CABLE ASSEMBLY, power: electrical; 3 cond, stranded, #20 AWG copper wire, plastic ins; materials in sequence from ins cond out, plastic, vinyl sleeving; term. fitting on first end, 1 female receptacle; cond on sec tinned 3/8" lg beyond end of jacket; Zenithrad part/dwg No. SG6596.	Connects receiver to battery.	3E4000.71

W2	<p>CABLE ASSEMBLY, power: electrical; Underwriters Laboratories Inc. type No. Pot-32; 2 cond, stranded, #18 AWG, thermoplastic ins; materials in sequence from ins cond out, thermoplastic, rated 300 v at 60° C; 6' lg o/a; term. fittings on first end, 2 Underwriters Laboratories Inc. male plug; cond on sec and extend ½" beyond jacket wire and tinned; Zenithrad part/dwg No. 11G3004.</p>	Connects receiver to A-C outlet.	3E4000.70
W4	<p>CABLE ASSEMBLY, power: electrical; Zenithrad part No. SG6634; 4 cond, stranded, No. 20 SRIR, thermoplastic ins; materials in sequence from ins cond out, thermoplastic ins, vinyl ins outer jacket; "A" 1-½ v, "B" 90 v; 16" lg o/a; term. fittings on first end, 1 Cinch plug part No. 54B17722; term. fittings on sec end, 1 plug Micarta Fab; 1st branch, 2-½" lg, one 8 prong plug term.; 2d branch, 3-¾" lg two 8 prong plug term.; 7 strands, No. 20 SRIR; Zenithrad part/dwg No. SG6634.</p>	Adapts receiver to Signal Corps type batteries.	3E4000.60
W3	<p>CABLE ASSEMBLY, RF: wave magnet extension cable, rf, parallel pair, 300 ohms; 2 cond, 7 strands ea, #32 AWG, copper wire, tinned or bared; polyethylene, .050" thk x .350" wd; rectangular shape; red polyethylene jacket; 44-½" lg, 48" lg excluding term.; plug on one end; snap fastener at second end; Zenithrad part/dwg No. SG6622.</p>	Antenna loop extension cable.	3E5999A-5.8
W5	<p>CABLE ASSEMBLY, power: electrical; 4 cond, stranded, No. 20 SRIR, thermoplastic ins; materials in sequence from ins cond out, yellow vinyl ins outer jacket; 1000 v rms max rated working voltage; 3000 v rms dielectric test; terminal fittings on one end; 1 Cinch plug part No. 54B17722; terminal fittings on sec end; 1 Micarta Fab plug; Zenithrad part/dwg No. 58G3014; branched; 1</p>	Adapts receiver to Signal Corps type batteries.	3E4000.68

2. Identification Table of Parts for Radio Receiver R-520/URR (contd)

Ref. symbol	Name of part and description	Function of Part	Signal Corps stock No.
W6	<p>branch 2-1/2" lg, 7 prong plug term.; sec branch 3-1/4" lg, 7 prong plug term.; third branch 5-1/2" lg, battery box term.; accom six 1-1/2 volt dry batteries; Zenithrad part/dwg No. SG6339.</p> <p>CABLE ASSEMBLY, power: electrical ; 4 cond, stranded, No. 20 SRIR, thermoplastic ins; materials in sequence from ins cond out; black vinyl ins outer jacket, 1000 v rms max rated working voltage, 3000 v rms dielectric test; 12" lg o/a; terminal fittings on one end; 1 Micarta Fab plug, Zenith part/dwg No. 58G3014; cond on sec end extend 6" beyond of jacket, wires tinned; Zenithrad part/dwg No. SG6940.</p>	<p>Adapts receiver to Signal Corps type batteries.</p>	3E4000.69
C8	<p>CAPACITOR, fixed; ceramic dielectric; 1.2 uuf ±20%; 500 v dcw; capacity change less than ±5% of 25° C value in temp range -50° to +80° C; ins, ceramic body, .295" lg, .160" dia; 2 term., axial wire lead type; term. mtd; fungiproofed; Quality Components type QC-1.2; Zenith rad part/dwg No. 22G8610.</p>	<p>Oscillator output coupling capacitor.</p>	3D9001E2
C15	<p>CAPACITOR, fixed; ceramic dielectric; 10 uuf ±.1 uuf; 500 vdcw; -330 uuf per uf per deg C, +500 uf; ins, ceramic jackets; .562" lg, .250" dia; 2 flexible wire type term.; terminal mtd; spec No. JAN-C-20A, Amend. 2, spec type No. CC21SL100F.</p>	<p>Oscillator range limiting capacitor.</p>	3D9010-105
C28	<p>CAPACITOR, fixed; ceramic dielectric; 15 uuf, ±10%, 500 vdcw; -330 uuf per uf per deg C, +500 uuf; ins,</p>	<p>External antenna short-wave coupling capacitor.</p>	3D9015-62

C33	ceramic jacket, .562" lg, .250" dia; 2 flexible wire term.; term. mtd; spec No. JAN-C-20A, Amend. 2, spec type No. CC21SL150K. CAPACITOR, fixed: ceramic dielectric; 24 uuf $\pm 10\%$ ; 500 vdcw; zero temp coef +120 uuf; ins. ceramic jacket; .562" lg .250" dia; 2 flexible wire term.; term. mtd; CC21CH240 spec No. JAN-C-20A, Amend. 2, spec type No. CC21J240J.	R-f grid, band spread tuning capacitor.	3D9024-65
C32	CAPACITOR, fixed: ceramic dielectric; 51 uuf $\pm 10\%$ ; 500 vdcw; —330 uuf per uf per deg C, +500 uuf; ins, ceramic jacket; .562" lg, .250" dia; 2 flexible wire term.; term. mtd; spec No. JAN-C-20A, Amend. 2, spec type No. CC21SL510K.	R-f grid, band spread tuning capacitor.	3D9051-33
C23	CAPACITOR, fixed: ceramic dielectric; 51 uuf $\pm 10\%$ ; 500 vdcw; —330 uuf per uf per deg C, +500 uuf; ins ceramic jacket; .562" lg, .250" dia.; 2 flexible wire term.; term. mtd; spec No. JAN-C-20A, Amend. 2, spec type No. CC26SH510J.	First audio plate rf bypass capacitor.	3D9051-81
C14 C42	CAPACITOR, fixed: ceramic dielectric; 120 uuf $\pm 5\%$ ; 500 vdcw; —330 uuf per uuf per deg C, +60 parts per million per deg C temp coef; ins, durez coated body; .560" lg .320" dia; 2 flexible wire term.; term. mtd; non-nutrient to fungus; spec No. JAN-C-20A spec type No. CC32SH121J except for durez coating.	C14: Oscillator grid coupling capacitor. C42: Oscillator tuning capacitor.	3D9120-48
C38	CAPACITOR, fixed: ceramic dielectric; 120 uuf, $\pm 5\%$ ; 500 vdcw; 0° temp coef, +60 parts per million per deg C temp coef; ins, durez coated body; 1.180" lg .320" dia; 2 flexible wire term.; term. mtd; non-nutrient to fungus; spec No. JAN-C-20A spec type No. CC32G121J except for durez coating.	Oscillator tuning capacitor.	3D9120-40

## 2. Identification Table of Parts for Radio Receiver R-520/URR (contd)

Ref. symbol	Name of part and description	Function of Part	Signal Corps stock No.
C12	CAPACITOR, fixed: ceramic dielectric; 240 uuf $\pm 5\%$ ; 500 vdcw; $-750$ uuf per uuf per deg C, $+120$ parts per million per deg C temp coef; ins durez coated body; 1.180" lg .320" dia; 2 flexible wire term.; term. mtd; non-nutrient to fungus; spec No. JAN-C-20A, spec type No. CG32-UJ241J except for durez coating.	Oscillator grid coupling capacitor.	3D9240-22
C1	CAPACITOR, fixed: ceramic dielectric; case, disc style; 4000 uuf $\pm 50$ or $-10G\%$ ; 500 vdcw; ins, ceramic jacket; $\frac{3}{4}$ " dia, 3/16" thk, 2 flexible wire term.; term. mtd; impr w/fungiproofing wax; Sprague part No. 36C25A1; Zenithrad part/dwg No. 22G3609.	External ground connector isolating capacitor.	3DA4-114
C5, C11, C21, C24, C34	CAPACITOR, fixed: ceramic dielectric; case, disc style; 10,000 uuf $-20$ , $+100\%$ ; 500 vdcw; ins, ceramic jacket; $\frac{3}{4}$ " dia, 3/16" thk; 2 flexible wire term.; term. mtd; impr w/fungiproofing wax; Sprague; part No. 36C1B9; Zenithrad part/dwg No. 22G3608.	C5: R-f filament bypass capacitor. C11: Converter screen grid bypass capacitor. C21: First audio grid coupling capacitor. C24: Second audio grid coupling capacitor. C34: Converter grid return bypass capacitor.	3DA10-618
C25	CAPACITOR, fixed: electrolytic; case style No. 17, MBCA ref dwg group 1; 1 sect., 12 uf capacity, 150 vdcw; 65° max ambient temp; tubular metal case w/outer ins tube; 2" lg, $\frac{5}{8}$ " dia.; 2 wire lead term.; one at ea end;	B+ supply filter capacitor.	3DB12-48



C45A, C45B, C45C, C45D	rubber ins; term. ins from can; clip mtd; Zenithrad part/dwg No. 22G3590. CAPACITOR fixed: electrolytic; case style No. 20, MBCA ref dwg group 1; 4 sect.; 60 uf one sect. 40 uf sec sect., 20 uf third sect., 200 uf fourth sect.; 150 vdcw one sect., 150 vdcw sec sect., 150 vdcw third sect., 10 vdcw fourth sect.; HS metal w/outer vinylite cover; 3-1/8" lg, 1-3/8" dia.; 8 solder lug term. on bottom; phenolic ins; term. ins from can; 4 twist lugs for mtg. on bottom, equally spaced; fungiprofed; Zenithrad part/dwg No. 22G3464.	C45A: Power supply filter capacitor. C45B: Filament supply filter capacitor. C45C: B+ supply filter capacitor. C45D: Filament filter capacitor.	3DB200-24
C6	CAPACITOR, fixed: mica dielectric; 47 uuf. ±10%; 500 vdcw; molded low loss bakelite case; 51/64" lg x 15/32" wd x 7/32" d; 2 wire lead term.; one at ea end; term. mtd; spec No. JAN-C-5, spec type No. CM20B470K.	R-f to converter coupling capacitor.	3K2047021
C30	CAPACITOR, fixed: mica dielectric; 270 uuf ±10%; 500 vdcw; molded low loss bakelite case; 51/64" lg x 15/32" wd x 7/32" d; 2 wire lead term.; one at ea end; term. mtd; spec No. JAN-C-5 spec type No. CM20B271K.	Antenna to r-f grid coupling capacitor.	3K2027121
C27, C37	CAPACITOR, fixed: mica dielectric; 470 uuf ±10%; 500 vdcw; molded low loss bakelite case; 51/64" lg x 15/32" wd x 7/32" d; 2 wire lead term.; one at ea end; term. mtd; spec No. JAN-C-5, spec type No. CM20B471K.	C27: Whip antenna coupling capacitor. C37: Oscillator plate coupling capacitor.	3K2047121
C7	CAPACITOR, fixed: mica dielectric; 1000 uuf ±10%; 500 vdcw; molded low loss bakelite case; 1-1/16" lg x 15/32" wd x 7/32" d; 2-wire lead term. one at ea end; term. mtd; spec No. JAN-C-5, spec type No. CM30B102K.	Converter signal grid coupling capacitor.	3K3010221
C41	CAPACITOR, fixed: mica dielectric; 2700 uuf ±5%; 500 vdcw; —200 to +200 parts per million per deg C temp coef; molded low loss bakelite case; 53/64" lg x 53/64" wd	Oscillator series padder capacitor (2-4 mc).	3K3027242

2. Identification Table of Parts for Radio Receiver R-520/URR (contd)

Ref. symbol	Name of part and description	Function of Part	Signal Corps stock No.
C39	<p>x 9-32" d; 2 wire lead term.; one at ea end; term. mtd; spec No. JAN-C-5, spec type No. CM30D272J.</p> <p>CAPACITOR, fixed: mica dielectric; 3000 uuf ±5%; 500 vdcw; molded low loss bakelite case; 53/64" lg x 53/64" wd x 9/32" d; 2 wire lead term.; one at ea end; term. mtd; spec No. JAN-C-5, spec type No. CM30B302J.</p>	Oscillator series padder capacitor (4-8 mc).	3K3030222
C36, C47	<p>CAPACITOR, fixed: paper dielectric; 1000 uuf ±20%; 800 vdcw; molded phenolic case; 53/64" lg x 53/64" wd x 9/32" h excluding term.; 2 wire lead term.; one at ea end; impr &amp; filling per spec JAN-C-91; no int gnd connections; terminal mtd; spec type No. CN301E102M.</p>	C36: Converter grid band spread coupling capacitor. C47: Tone control capacitor.	3DA1-283
C18	<p>CAPACITOR, fixed: paper dielectric; 3000 uuf ±20%, 400 vdcw; molded phenolic case; 51/64" lg x 15/32" wd x 7/32" d excluding term.; 2 wire lead term.; one at ea end; wax impr; no int gnd connections; terminal mtd; spec No. JAN-C-91, spec type No. CN20E302M.</p>	I-f screen grid bypass capacitor.	3DA3-154
C3	<p>CAPACITOR, fixed: paper dielectric; 10,000 uuf ±10%; 400 vdcw; molded phenolic case; 1-3/8" lg x 41/64" wd x 9/32" h excluding term.; 2 wire lead term.; one at ea end; impr and filling per spec JAN-C-91; no int gnd connections; terminal mtd; spec type No. CN41E103K.</p>	Antenna loading capacitor.	3DA10-619
C26	<p>CAPACITOR, fixed: paper dielectric; 10,000 uuf ±20%; 600 vdcw; molded phenolic case; 1-15/32" lg x 49/64" wd x 11/32" h excluding term.; 2 wire lead term.; one at ea</p>	Audio output plate bypass capacitor.	3DA10-620

C43	end; impr and filling per spec JAN-C-91; no int gnd connections; spec type No. CN42E103M. CAPACITOR, fixed: paper dielectric 10,000 uuf $\pm 20\%$ ; 400 vdcw; molded phenolic case; 1-3/8" lg x 41/64" wd x 9/32" h excluding term.; 2 wire lead term.; one at ea end; impr & filling per spec JAN-C-91; no int gnd connections; terminal mtd; spec type No. CN41E103M.	Converter ave bypass capacitor.	3DA10-441
C44, C48, C49	CAPACITOR, fixed: paper dielectric; 20,000 uuf $\pm 20\%$ ; 300 vdcw, molded phenolic case; 53/64" lg x 53/64" wd x 11/32" h excluding term.; 2 wire lead term.; one at ea end; impr and filling optional per spec JAN-C-91; no int gnd connections; terminal mtd; spec No. JAN-C-91; spec type No. CN35E203M.	C-44: I-f ave bypass capacitor. C48, C49: Tone control capacitors.	3DA20-192
C22	CAPACITOR, fixed: paper dielectric; 20,000 uuf $\pm 20\%$ ; 600 vdcw; molded phenolic case, 1-15/32" lg x 49/64" wd x 11/32" h excluding term.; 2 wire lead term.; one at ea end; impr and filling per spec JAN-C-91; no int gnd connections; spec No. JAN-C-91; spec type No. CN42E203M.	First audio screen grid bypass capacitor.	3DA20-210
C46	CAPACITOR, fixed: paper dielectric; 47,000 uuf $\pm 20\%$ ; 600 vdcw; 1-1/16" lg, .400" dia; 2 axial wire term.; one at ea end; impr and filling per spec JAN-C-25; no int gnd connections; vinyl sleeving outer jacket; spec No. JAN-C-25; spec type No. 81P47306S3.	Power line bypass capacitor.	3DA47-27
C4	CAPACITOR, fixed: paper dielectric; 50,000 uuf $\pm 20\%$ ; 300 vdcw; molded phenolic case; 1-15/32" lg x 49/64" wd x 11/32" h excluding term.; 2 wire lead term.; one at ea end; impr and filling optional per spec JAN-C-91 no int gnd connections; spec No. JAN-C-91; spec type No. CN42E503M.	R-f ave return capacitor.	3DA50-364

## 2. Identification Table of Parts for Radio Receiver R-520/URR (cont'd)

Ref. symbol	Name of part and description	Function of Part	Signal Corps stock No.
C10, C29	CAPACITOR, fixed: paper dielectric; 50,000 uuf $\pm 20\%$ ; 400 vdcw; molded phenolic case 1-15/32" lg x 49/64" wd x 13/32" h excluding term.; 2 wire lead term.; one at ea end; impr and filling per spec JAN-C-91; no int gnd connections; terminal mtd; spec No. JAN-C-91; spec type No. CN43E503M.	C10 R-f bypass capacitor. C29: B- to chassis bypass capacitor.	3DA50-304
C9	CAPACITOR, fixed: paper dielectric; 100,000 uuf $\pm 20\%$ ; 400 vdcw; molded phenolic case; 1-15/32" lg x 49/64" wd x 13/32" h excluding term.; 2 wire lead term. one at ea end; impr and filling per spec JAN-C-91; no int gnd connections; terminal mtd; spec No. JAN-C-91; spec type No. CN43E104M.	Filament bypass.	3DA100-838
C2A, C2B, C2C, C2D, C2E, C2F	CAPACITOR, variable: air dielectric; plate meshing type, 3 sect.; 444.7 uuf max all 3 sect., 15 uuf min all 3 sect.; ea sect. straight line capacity tuning characteristic; 3-3/16" lg x 2-3/16" wd x 2-1/8" h excluding term. and bushings; screw-driver adjustment, 180° cw rotation; base ins from chassis; 5 solder lug term.; three #6-32 weld nuts on 1-15/16" x 2-9/16" mtg ctr on .062 C.R. steel brackets; Radio Condenser Corp. model No. 325; Zenithrad part/dwg No. 22G3465.	C2A: Main tuning capacitor r-f grid tuning. C2B: Main tuning capacitor, r-f grid trimmer. C2C: Main tuning capacitor, converter grid tuning. C2D: Main tuning capacitor, converter grid trimmer. C2E: Main tuning capacitor, oscillator tuning. C2F: Main tuning capacitor, oscillator trimmer.	3D9444VE7

C40A, C40B	CAPACITOR, variable: mica dielectric; compression type; 2 sect.; 1 sect. 30 uuf, 1 sect. 55 uuf at aprox $\frac{3}{8}$ turn open; $\frac{3}{4}$ " lg x 23/32" wd x $\frac{3}{8}$ " h o/s; 4 solder lug term., 2 at ea end; bracket mtd; 1 hole No. 6-32 tap; screw-driver slot adj; ceramic base; Electro Motive; Zenithrad part/dwg No. 22G3491.	Dual trimmer capacitor; C40 A 4-8 mc oscillator trimmer, C40B 2-4 mc oscillator trimmer.	3D9055V-21
C35A, C35B	CAPACITOR, variable: mica dielectric; compression type; 2 sect., 55 uuf ea at aprox $\frac{3}{8}$ turn open; $\frac{3}{4}$ " lg x 23/32" wd x $\frac{3}{8}$ " h o/a; 4 solder lug term., 2 at ea end; bracket mtd; 1 hole No. 6-32 tap; screw-driver slot adj; ceramic base per spec JAN-I-10; Electro Motive part No. DP56208-Rev.-A.	Dual trimmer capacitor; C35 A 4-8 mc r-f trimmer, C35B 2-4 mc r-f trimmer.	3D9055V-20
C31A, C31B	CAPACITOR, variable: mica dielectric; compression type 2 sect.; 75 uuf ea at aprox $\frac{3}{8}$ turn open; $\frac{3}{4}$ " lg x 23/32" wd x $\frac{3}{8}$ " h o/a; 4 solder lug term., 2 at ea end; bracket mtd; 1 hole No. 6-32 tap; screw-driver slot adj; ceramic body; Electro Motive; Zenithrad part/dwg No. 22G3467.	Dual trimmer capacitor; C31 A 4-8 mc antenna trimmer; C31B 2-4 mc antenna trimmer.	3D9075V-49
C13	CAPACITOR, variable; mica dielectric; compression type; one sect.; 200 to 750 uuf; 250 vacw; 25/32" lg, $\frac{5}{8}$ " wd (approx), 9/16" h (approx) o/a; 2 solder lug term., on brack; bracket mtd; 1 hole No. 6-32 tap; screw-driver slot adj; ceramic body; fungiproofed; Electro Motive; Zenithrad part/dwg No. 22G3490.	Broadcast padder capacitor.	3D9750V-5
A 1	CLAMP, electrical: steel, cad pl, clear iridite; fastening device, 11/16" wd ear fits into clamp A 2; 2" lg x 1 $\frac{3}{8}$ " wd x $\frac{3}{4}$ " h o/a; two .25" dia holes on 1.250" mtg ctr; $\frac{3}{4}$ "; dia material; one half of bracket mtg for ant Zenithrad part/dwg No. 17G3026.	Whip antenna mounting clamp.	2Z2642.830
A 2	CLAMP, electrical: steel, cad pl, clear iridite; fastening device; one $\frac{3}{4}$ " x 5/32" slot; 2" lg x 1-5/16" wd x $\frac{3}{4}$ " h	Whip antenna mounting clamp.	2Z2642.829

## 2. Identification Table of Parts for Radio Receiver R-520/URR (contd)

Ref symbol	Name of part and description	Function of Part	Signal Corps stock No.
O 50	<p>o/a two .218" dia holes on 1.250" mtg ctr; <math>\frac{3}{4}</math>" dia material; one-half of bracket mtg for ant; Zenithrad part/dwg No. 12G3114.</p> <p>CLAMP, electrical; steel, cad pl w clear iridite; fastening device, 1 bolt type; <math>\frac{1}{2}</math>" lg x <math>11/32</math>" wd x <math>3/16</math>" h o/a; mtd by 1 mtg hole .149" dia, in base of clamp; designed to hold material <math>\frac{1}{8}</math>" dia mix; holds pilot light wire leads; Cinch part No. 1065 P24-3; Zenithrad part/dwg No. 17G3028.</p>	Pilot light wire clamp.	2Z2642-831
O 51	<p>CLAMP, electrical: steel, fastening device, stud type; 1-19/32" lg x 1-1/16" wd x 9/16" h o/a; mtd by one 11/64" slot, fits over stud, designed to hold tube w <math>\frac{5}{8}</math>" dia approx; thermal resistor tube clamp; Times Facsimiles part No. 1 Hot; Zenithrad part/dwg No. 17G3029.</p>	Thermal resistor clamp.	2Z7780-113
O 60	<p>CLIP ASSEMBLY, electrical: 5 tube clips; ferrule type <math>\frac{3}{4}</math>" dia ferrule accom, steel, cad pl w/clear iridite; mtd on brass bracket; mts by two 5/32" dia holes 4-11/16" c to c; 5-13/16" lg x <math>\frac{5}{8}</math>" wd x 13/16" h o/a; Zenithrad part/dwg No. SG6632.</p>	Holder for spare electron tubes.	2Z2714-3
TB5	<p>CLIP ASSEMBLY, electrical: 2 clips; ferrule type, <math>\frac{1}{4}</math>" dia, phosphor bronze, nickel pl; mtd on phenolic board, mts by two <math>\frac{1}{8}</math>" dia holes <math>\frac{3}{8}</math>" mtg ctr; 2-1/16" lg x <math>\frac{3}{4}</math>" wd x 17/32" h o/a; tropic-proofed; holds alinement wrench; Cinch part No. 801; Zenithrad part/dwg No. 83G146.</p>	Alinement wrench holder.	2Z2714-4

O 1	CLIP, electrical: beryllium copper; 3" lg x 3/4" wd; two mtg holes .128" dia spaced 1-1/8" c to c for 2 snap fasteners; Zenithrad part/dwg No. 19G3023.	Holder for loop extension cable and suction cups.	2Z2712.368
O 2	CLIP, electrical: beryllium copper; 2-9/16" lg x 1/2" wd x .0226" thk; heat treated; Zenithrad part/dwg No. 19G3024.	Holder for spare fuses.	2Z2712.369
O 18 thru O 35	CLIP, electrical: ferrule type; steel; cad pl, clear iridite; 27/64" lg x 23/64" wd x .093" h; coil form clip; used as coil retaining clip; Tinnerman Prod part No. C3918012-157; Zenithrad part/dwg No. 19G3021.	Coil retaining clips.	2Z2712.365
O 36, O 37	CLIP, electrical: ferrule type; steel, cad pl, clear iridite; .405" lg x .405" wd x 17/64" h; coil retaining clip; Kast Products Co. part No. K110; Zenithrad part/dwg No. 19G3022.	0 36, 0 37: Coil retaining clips.	2Z2712.366
O 38	CLIP, electrical: ferrule type; steel; cad pl, clear iridite; 23/32" lg x 11/16" wd x 19/32" h; 5/8" jaw opening fully spread; Prestole Corp. part No. 500-625; Zenithrad part/dwg No. 19G3025.	Capacitor retaining clip.	2Z2712.88
O 58	CLIP, electrical: ferrule type; steel, cd pl, clear iridite; 19/32" lg x 7/8" h x 27/32" wd; 13/16" jaw opening fully spread; one .140" dia mtg hole, centrally located; Prestole Corp. part No. 500-750; Zenithrad part/dwg No. 19G3028.	Holder for spare thermal resistor.	2Z2712.248
O 59	CLIP, electrical: ferrule type, steel, cad pl, clear iridite; 9/16" lg x 1/2" h x 3/8" wd; 11/32" jaw opening fully spread; one mtg hole .140" dia, centrally located; Prestole Corp. part No. 500-375; Zenithrad part/dwg No. 19G3027.	Holder for spare neon glow lamp.	2Z2712.324

## 2. Identification Table of Parts for Radio Receiver R-520/URR (contd)

Ref. symbol	Name of part and description	Function of Part	Signal Corps stock No.
O 70	CLIP: electrical; copper, cad pl; 2-15/16" lg, 1/2" w, .0226" thk o/a; fungusproofed; antenna wire clip; Zenithrad part/dwg No. 19G3030.	Holder for hanked antenna wire.	2Z2712-367
L3	COIL, RF: 43 turns; #29 AWG; copper; enamel-covered cond; one dwg; closewound solenoid; tye C.F.G. per MIL-P-14A; coil dimen, excluding term., mtg attachments and tuning devices, 5/8" lg, 9/32" dia; o/a coil form dimen, 3-3/4" lg, .218" dia; wire lead term. located one at ea end of coil form; term. mtd; Zenithrad part/dwg No. 20G3015.	Oscillator grid, RF choke.	3C339-27
L4	COIL, RF: 95 turns, #44 AWG, 15 strands, copper, double celanese covered cond; one universal wdg; type C.F.G. per MIL-P-14A; coil dimen, excluding mtg attachments and tuning devices, 13/64" lg, 37/64" dia, o/a coil form dimen, 3-3/4" lg, 7/32" dia; 2 wire lead term. located one at each end; term. mtd; color coded; Zenithrad part/dwg No. 20G3016.	Antenna loading coil.	3C1084-10
L5	COIL, RF: 18 turns, AWG, copper, single nylon-covered cond, one spaced solenoid winding; cosmolute coil form; iron core; coil dimen, excluding term., mtg attachments and turning devices, 29/64" lg; 7/16" dia; o/a dimen for coil form, 1-15/43" lg, .375" dia; adj iron core, tuning wrench adj, located inside coil form at one end; 3 staple type term., clip mtd; Zenithrad part/dwg No. SG6546.	Antenna coil assembly, 4-8 mc.	3C1084D-14



L6, L13	<p>COIL, RF: 43 turns; #34 AWG; copper, single nylon covered cond; one spaced solenoid wdg; cosmolite form; iron core; coil dimen, excluding term, mtg attachments and tuning devices; 9/16" lg, 13/32" dia; o/a coil form dimen, .375" dia, 1-15/32" lg; adj iron core, tuning wrench adj located inside coil form at one end; 2 staple type term. located on side of coil form; clip mtd; Zenithrad part/dwg No. SG6558.</p>	L6: Antenna coil assembly, 2-4 mc. L13: R-f coil assembly, 2-4 mc.	3C1084D-17
L7	<p>COIL, RF: 8-1/2 turns; #32 AWG, copper; double-celanese covered cond; one universal wdg; black bakelite form; iron core; coil dimen, excluding term. mtg attachments, and tuning devices, 7/64" lg, 21/64" dia; o/a coil form dimen 11/32" dia, 3/4" lg; adj iron core, tuning wrench adj; inside coil form at one end; 2 wire lead term.; clip mtd; top and clip painted green; short wave coil, antenna sect. Zenithrad part/dwg No. SG6534.</p>	Antenna coil assembly, 10M.	3C1084D-11
L8	<p>COIL, RF: 11 turns, #32 AWG; copper; double celanese covered, cond, one universal wgd; black bakelite form; iron core; coil, dimen, excluding term. mtg attachments and tuning devices, 1/8" lg, 11/32" dia; o/a coil form dimen, 11/32" dia; 3/4" lg; adj iron core, tuning wrench adj, inside coil form at one end; 2 wire lead term., clip mtd; top and clip painted yellow; short wave coil, antenna section; Zenithrad part/dwg No. SG6535.</p>	Antenna coil assembly, 19M.	3C1084D-12
L9	<p>COIL, RF: 14-1/2 turns; #32 AWG; copper; double-celanese covered cond; one wdg, one universal wdg; black bakelite form; iron core; coil dimen, excluding term. mtg attachments and tuning devices, 1/8" lg, 11/32" dia; o/a coil form dimen 11/32" dia, 3/4" lg; adj tuning, tuning wrench adj, inside coil form at one end; 2 wire lead term.</p>	Antenna coil assembly, 25M.	3C1084D-13

## 2. Identification Table of Parts for Radio Receiver R-520/URR (contd)

Ref. symbol	Name of part and description	Function of Part	Signal Corps stock No.
L10	<p>clip mtd; top and clip painted white; short-wave coil, antenna sect.; Zenithrad part/dwg No. SG6536.</p> <p>COIL, radio frequency: 19 turns, #32 AWG, copper, double-celane covered, conductor; one universal wdg, black bakelite form; iron core; coil dimen, excluding term., mtg attachments and tuning devices, 5/32" lg, 3/8" dia, o/a coil form dimen, 11/32" dia, 3/4" lg; adj. iron core, tuning wrench adj inside coil form at one end; 2 wire lead term.; clip mtd, top and clip painted blue; short-wave coil, antenna sect.; Zenithrad part/dwg No. SG6537.</p>	Antenna coil assembly, 31M.	3C1084D-21
L11	<p>COIL, RF: 67 turns per pie; #34 AWG, copper; double-celane covered cond, one wdg, 2 pie universal, type C.F.G. per MIL-P-14A; coil dimen, excluding term., mtg attachments and tuning devices, 1/2" lg, 1/2" dia, o/a form dimen, 3-3/4" lg, 7/32" dia; 2 wire lead term.; located one at each end of coil form; term. mtd, RF shunt coil; Zenithrad part/dwg No. 20G3014.</p>	RF shunt coil.	3C1084D-9
L12	<p>COIL, RF: 18 turns, #26 AWG, copper single nylon covered cond, one spaced solenoid winding; cosmolute form, iron core, coil dimen, excluding term., mtg attachments and tuning devices, 29/64" lg 7/16" dia; o/a coil form dimen, .375" dia, 1-15/32" lg; adj iron core, tuning wrench adj located inside coil form at one end, 2 staple-type terms. located on one side of coil form; clip mtd; Zenithrad part/dwg No. SG6539.</p>	RF coil assembly, 4-8 mc.	3C1084D-20

L14	<p>COIL, RF: 11-<math>\frac{1}{2}</math> turns; #32 AWG; copper; double-celanes covered cond one universal wdg; black bakelite form; iron core; coil dimen, excluding term., mtg attachments and tuning devices, <math>\frac{1}{8}</math>" lg, 11/32" dia; o/a coil form dimen, 11/32" dia, <math>\frac{3}{4}</math>" lg; adj iron core; tuning wrench adj, inside coil form at one end; 2 wire lead term.; clip mtd side of clip painted pink; short wave coil, r-f sect. Zenithrad part/dwg No. SG6530.</p>	RF coil assembly 16M.	3C1084D-19
L15	<p>COIL, RF: 13-<math>\frac{1}{2}</math> turns, #32 AWG, copper; double celanese covered, cond, one wdg universal wdg; black bakelite form; iron core; coil dimen, excluding term., mtg attachments and tuning devices, 9/64" lg <math>\frac{3}{8}</math>" dia; o/a form dimen, 11/32" dia, <math>\frac{3}{4}</math>" lg; adj iron core, tuning wrench adj inside coil form at one end; 2 wire lead term.; clip mtd, side of clip painted orange; short wave coil, r-f sect. Zenithrad part/dwg No. SG6531.</p>	RF coil, 19M.	3C1084D-18
L16	<p>COIL, RF: 19-<math>\frac{1}{2}</math> turns, #32 AWG; copper, double-celanes covered cond, one universal wdg; black bakelite form, iron core, coil, dimen, excluding term., mtg attachments and tuning devices, 3/16" lg <math>\frac{3}{8}</math>" dia; o/a coil form dimen, 11/32" dia, <math>\frac{3}{4}</math>" lg, and iron core; tuning wrench adj; inside coil form at one end; 2 wire lead term.; clip mtd, side of clip painted gray; short-wave coil, r-f sect.; Zenithrad part/dwg No. SG6532.</p>	RF coil, 25M.	3C1084D-16
L17	<p>COIL, RF: 26 turns, #32 AWG, copper, double-celanes covered cond, one universal wdg; black bakelite form, iron core, coil dimen, excluding term. mtg attachments and tuning devices, 3/16" lg, 13/32" dia; o/a coil form dimen, 11/32" dia, <math>\frac{3}{4}</math>" lg; adj iron core; tuning wrench adj inside coil form at one end; 2 wire lead term., clip</p>	RF coil, 31M.	3C1084D-15

## 2. Identification Table of Parts for Radio Receiver R-520/URR (contd)

Ref symbol	Name of part and description	Function of Part	Signal Corps stock No.
L20	<p>mtd, side of clip painted brown; short-wave coil, r-f sect. Zenithrad part/dwg No. SG6533.</p> <p>COIL, RF: 5-½ turns, #29 AWG; copper; enameled cond; one solenoid wdg; black bakelite form; powdered iron core; coil dimen, excluding term., mtg attachments and mtg devices, 1/16" lg 9/32" dia; o/a coil form dimen 11/32" dia, ¾" lg; adj iron core, tuning wrench adj located inside coil form at one end; 2 wire lead term., clip mtd, side of clip painted red; short-wave oscillator coil; Zenithrad part/dwg No. SG6540.</p>	Oscillator coil assembly 16M.	3C1081-7B
L21	<p>COIL, RF: 9-½ turns; #29 AWG, copper, enameled cond, one solenoid wdg; black bakelite form; powdered iron core; coil dimen, excluding term., mtg attachments and tuning devices, 1/8" lg 9/32" dia; o/a dimen of coil form 11/32" dia, ¾" lg; adj iron core, tuning wrench adj located inside coil form at one end; 2 wire lead term. clip mtd, side of clip painted green; short-wave oscillation coil; Zenithrad part/dwg No. SG6541.</p>	Oscillator coil assembly, 19M.	3C1081-7C
L22	<p>COIL, RF: 14 turns, #32 AWG, copper, double-celanes covered cond; one universal wdg; black bakelite form, iron core, coil dimen, excluding term., mtg attachments and tuning devices, 9/64" lg, 11/32" dia; o/a coil form dimen 11/32" dia, ¾" lg; adj iron core, tuning wrench adj located inside coil form at one end; 2 wire lead</p>	Oscillator coil assembly 25M.	3C1081-7D

L23	<p>term.; clip mtd; side of clip painted white; short-wave oscillator coil; Zenithrad part/dwg No. SG6542.</p> <p>COIL, RF: 20 turns, #32 AWG, copper, double-celanese covered conductor one universal wdg; black bakelite form; iron core; coil dimen, excluding term., mtg attachments and tuning devices, 3/16" lg 23/64" dia; o/a coil form dimen, 11/32" dia, 3/4" lg; adj iron core; tuning wrench adj located inside coil form at one end; 2 wire lead term.; clip mtd side of clip painted blue; short-wave oscillator coil; Zenithrad part/dwg No. SG6543.</p>	Oscillator coil assembly, 31M.	3C1081-79
P15	<p>CONNECTOR, adapter: 4 cont; 2 round, slotted male, 2 flat female, straight type; o/a dimen; 1-21/32" lg, 1-3/8" dia. o/a cont electrical ratings, 2.64 amps; 250 v; cyl body, phenolic, brown; O. D. Wood Electric Co. part No. 2064.</p>	Adapts line plug to foreign receptacles.	2Z303-2
P16	<p>CONNECTOR, adapter: 4 cont; 2 round, slotted male, 2 flat female, straight type; o/a dimen; 1-17/32" lg, 1-3/8" dia o/a; cont electrical ratings, 2.64 amps, 250 v; cyl body, phenolic, brown; C. D. Wood Electric Co., part No. 2073.</p>	Adapts line plug to foreign receptacles.	2Z303-1
P17	<p>CONNECTOR, adapter: 4 cont, 2 male, 2 female, 2 flat, 2 round bayonet type; straight type; 7/8" lg, 1-3/16" dia o/a; cont electrical ratings, 2.64 amps, 250 v; cyl body, phenolic body; brown, C. D. Wood Electric Co., part No. 2089.</p>	Adapts line plug to foreign receptacles.	6Z111
P18	<p>CONNECTOR, adapter: 4 cont; 2 male, 2 female, 2 flat, 2 screw-in type; straight type; 1-9/32" lg, 1-3/16" dia o/a; cont electrical ratings, 2.64 amps, 250 v; cyl body, phenolic, brown, C. D. Wood Electric Co., part No. 2053.</p>	Adapts line plug to foreign receptacles.	6Z560-9

## 2. Identification Table of Parts for Radio Receiver R-520/URR (contd)

Ref. symbol	Name of part and description	Function of Part	Signal Corps stock No.
P1, P8	CONNECTOR, plug: 3 cont; male; round; pol; straight type; 1" lg, 7/32" wd 1/2" d o/a; NPG phenolic with 3 nickel-plated contact pins .093" dia; term. mtd; Alcon Metal Products, part No. 18-1011.	P1: Antenna plug. P8: Antenna extension plug.	2Z3023-106
P3, P6, P7	CONNECTOR, plug: 8 cont; male, round; straight type; .656" lg; 61/64" dia o/a; CFG plastic with brass, nickel-plated contact pins; term. mtd; Cinch Mfg. Corp., part No. 54B17722.	Battery connector plug.	2Z3028-88
P4	CONNECTOR, plug: 8 cont, male, round; straight type; .656" lg, 61/64" dia o/a; CFG plastic with brass, nickel pl contact pins; term. mtd; Cinch Mfg. Corp., part No. 54B17723.	Battery connector plug.	2Z3028-89
P5	CONNECTOR, plug: 4 cont; male, round, pol; straight type; 1/2" lg, 1" dia /oa; bakelite with brass cont; mtd by retainer cap; Zenithrad part/dwg No. 58G3014.	Battery connector plug.	2Z3024-119
P9	CONNECTOR, plug: Two male flat cont, straight type, 1-1/8" lg, 9/16" wd, 1-7/16" h, excluding term; Y-shaped; Zenithrad part/dwg No. 58G3022.	A-c line plug used on W2.	2Z3022-194
J1	CONNECTOR, receptacle: 3 cont, female, round; straight type; 1-1/2" lg, 1/2" w 7/64" thk o/a, excluding protruding cont; 2 mtg holes, .136" dia, spaced 1.187" c to c; fungus-proofed; Zenithrad part/dwg No. 78G3024.	Receptacle for loop antenna extension cable.	2Z3064-158
J2	CONNECTOR, receptacle; 2 cont, female; round; pol; straight type; 1-7/16" lg, 1" wd 3/4" d o/a, including	Connector for voltage adapter.	2Z3056-13

P2	<p>protruding cont; mtg data, 3 mtg holes, .140" dia; Zenithrad part/dwg No. 78G3022.</p> <p>CONNECTOR, receptacle: 2 cont, male, round, pol; straight type; 15/16" lg, 1-1/16" wd 1/16" thk, overall, excluding protruding cont; 2 mtg holes, .136" dia, spaced .687" c to c; Zenithrad part/dwg No. 58G3012.</p>	<p>Male plug base for voltage adapter.</p>	2Z3022-187
A 3	<p>COVER ASSEMBLY, protective: aluminum and polyethylene; anodized aluminum finish; translucent polyethylene; 7-5/8" lg, 4-15/16" wd, 3-5/8" d o/a; two sect. riveted together; two .156" dia mtg holes on 1-3/4" mtg ctr; has slot 1-3/8" wd 2" lg to allow insertion of male antenna connection; also a retaining strip used to captivate screws used as a protective cover for electrical components in tuning sect.; Zenithrad Radio Corp., Zenithrad part/dwg No. SG6625.</p>	<p>Protect RF tuning assembly.</p>	2Z3351-529
N1	<p>COVER, dial: polystyrene; 3 finishes applied from back; metallic copper, pale gold, brown, 16-1/8" lg, 7-1/2" wd, 1-13/32" d o/a; four mtg holes; .240" counter-bore, 1/8" dia along top edge; three mtg holes 1/8" dia along bottom edge; depressed lettering on 7 band indicator button openings; black lettering at four tone selector openings silk screen lettering on inside of window openings; recessed lettering above grille opening; escutcheon plate; Zenithrad part/dwg No. 57G3132.</p>	<p>Decorative cover for dial.</p>	2Z3351-527
N2	<p>COVER, electrical switch: aluminum; anodize; 1-3/16" lg, 1-9/32" wd .52" thk o/a; one .240" x 19/64" rectangular opening on lower left side of plate; one 9/16" x .128" oval on upper left side of plate; designation plate marked, top to bottom; "110 V AC-DC, 220 V DC, 220</p>	<p>Voltage designation plate.</p>	2Z3351-528

## 2. Identification Table of Parts for Radio Receiver R-520/URR (cont'd)

Ref. symbol	Name of part and description	Function of Part	Signal Corps stock No.
O 64	<p>V AC"; used as identification cover for voltage adapter assembly; Zenithrad part/dwg No. 57G3138.</p> <p>DIAL CORD AND EYELET ASSEMBLY: nylon cord, black; American brass eyelets, 13" lg w 2 eyelets attached; Zenithrad Radio Corp., Zenithrad part/dwg No. SG6616.</p>	Method of tuning gang capacitor.	2Z3765-21
O 65	<p>DIAL CORD AND EYELET ASSEMBLY: nylon, black, American brass eyelets, No. 934; 16" lg with 2 eyelets attached; Zenithrad Radio Corp., Zenithrad part/dwg No. SG6617.</p>	Rotates dial pointer in conjunction with O 66.	2Z3765-20
A 4	<p>DIAL: scale, scale data, "KC" 550 to 1600 CW graduated in increments of 50 and 100 KC, standard broadcast, 180° arc; "meg", 2 to 4 CW, graduated in increments of 100 KC, 2-4 MC 180° arc; "meg", 4 to 8 CW, graduated in increments of 200 KC, 4-8 MC, 180° arc; "meg", 17.5 to 18.1 CW, graduated in increments of 100 KC, 16 M, 180° arc; "meg", 11.6 to 12.0 CW, graduated in increments of 100 KC, 25M, 180° arc; "meg", 9.4 to 9.8 CW, graduated in increments of 100 KC, 31 M, 180° arc; "meg", 14.9 to 15.5 CW, graduated in increments of 100 KC and 200 KC, 19 meter band, 180° arc; 8-5/16" lg, 5-5/16" wd 21/32" dia ctr hole; flange mtd; clear polystyrene; metallic copper; Zenithrad art/dwg No. 26G3004.</p>	Visual indicator of frequencies within range of R-520/URR.	2Z3723-432



V1, V3	TUBE ELECTRON: pentode, glass envelope; 7 pin-type term. located on bottom; amplifier tube; type 1U4; Sylvania Prod type No. 1U4, Zenithrad part/dwg No. 100G3016.	Rf: amplifier. If amplifier.	2J1U4
V2	TUBE ELECTRON: heptode; glass envelope; 7 pin-type term. located on bottom pentagrid converter tube; type 1L6 Sylvania Electric Products, Inc. type No. 1L6, Zenithrad part/dwg No. 100G3050.	Converter.	2J1L6
V4	TUBE ELECTRON: diode pentode; glass envelope; 7 pin-type term. located on bottom; detector and audio amplifier tube; type designation data type 1U5; Sylvania Prod type No. 1U5, Zenithrad part/dwg No. 100G3042.	2nd detector, 1st audio and Avc	2J1U5
V5	TUBE ELECTRON: pentode; glass envelope; 7 pin-type term located on bottom; power amplifier tube; type • 3 V4; Tung Sol Electric Inc. type No. 3 V4, Zenithrad part/dwg No. 100G3043.	Audio output amplifier.	2J3V4
O 12, O 13	FASTENER, snap; 9/64" h, 27/64" dia o/a, brass; nickel pl; mtd by 1/8" dia hole, centrally located; United-Carr part No. B-S-12302; Zenithrad part/dwg No. 159G3001.	Provides necessary electrical connection for loop antenna when extended remotely.	6Z3810-4.8
F1	FUSE, cartridge; 3/16" amp; 250 v; instantaneous; ferrule type; 1/4" lg, 1/4" dia.; glass body; open link visible within glass body; 1-1/4" lg, 1/4" dia o/a; unit package 5 per box; Littelfuse type No. 3AG Zenithrad part/dwg No. 136G3006.	Receiver protection.	3Z2592-1
E11	FUSEHOLDER: extractor post type; accommodates 1 fuse, cartridge type; o/a dimen, 1-1/4" lg, 1/4" dia; phenolic body; nickel pl brass cont, ferrule type; o/a dimen, 2.219" lg, .719" dia; 2 solder lug term.; single .510" dia mtg hole; Littelfuse part No. 34005-45, Zenithrad part/dwg No. 62G3033.	Holds fuse.	3Z3282-11.22

## 2. Identification Table of Parts for Radio Receiver R-520/URR (contd)

Ref. symbol	Name of part and description	Function of Part	Signal Corps stock No.
O 44, O 45, O 46, O 47, O 48, O 49	GROMMET: rubber; grade RN300, black; round; 1/4" tk, 1/2" OD, 3/16" ID, 1/16" wd between flanges; self-retaining type; Reliable Rubber Co., part No. 8051; Zenithrad part/dwg No. 125G3011.	O 44, O 45, and O 46: Tuning capacitor. cushioning grommet. O 47, O 48, and O 49: Speaker cushioning grommet.	6Z4911E
O 42, O 43	GRCMMET: nylon, molded, black; two-piece circular; .468" dia, .375" lg; self-retaining type; Heyman Mfg. Co., part No. 3-P-HYCO; Zenithrad part/dwg No. 125G3009, 125G3010.	Relieves ac line cord tension	6Z4865-4
O 69	HANDLE, cabinet: polystyrene, brown color; "U" shaped, molded finger grip, a/o dimen, 5" lg, 2-7/16" h, 3/4" d; molded pivots, 7/32" lg, 3/8" dia, Beco Plastics Co., part No. 1000; Zenithrad part/dwg No. 36G3002.	Cabinet handle.	6Z504-3
O 39	INDICATOR, frequency channel: mechanically operated; pointer w/disk; friction mtd split hub 7/16" lg, .251" ID at base of hub; 4" lg, 1-5/16" dia of disk, 19/32" h o/a, J. H. Winns Sons, part No. 3441; Zenithrad part/dwg No. 59G3001.	Indicates frequency to which receiver is tuned.	2C1582-30
J4	INSERT, electrical connector battery type 4 round, female cont, 5/16" lg, 1/8" ID; phenolic, tropicproofed finish; round; 15/16" dia, 7/16" d o/a; socket cap holds insert in place; pol by position of cont; Zenithrad part/dwg No. 78G3025.	Connects receiver for battery use.	2Z5400-77

E3, E4	INSULATION, electrical, sleeving; rigid, vinylite; 19/32" ID, 5/64" wall thickness; supplied in fabricated lengths 3/8" lg o/a; not rated for dielectric strength; clear color; Zenithrad part/dwg No. 199G3027.	Base insulation for whip antenna.	3G2253-1.2
E12, E13	INSULATOR, bushing: phenolic, FBE grade, natural; fungusproofed finish; round, round shank MBCA, ref dwg group 9; item code No. 78, MBCA ref dwg group 9, dimen, MBCA ref dwg group 9, D — 1/2" E — .035" H — .172" G — .281"; Zenithrad part/dwg No. 93G3105.	Insulates resistor in voltage adapter from chassis.	3G100-305
E21	INSULATOR, bushing: phenolic, MFE grade, brown; round w/round shank; MBCA ref dwg group 9, item code No. 76, MBCA ref dwg group 9, dimen, MBCA ref dwg group 9, H—25/64", E—1/32", G—1/2", D—5/8", L—3/32", Switchcraft, Inc. part No. M 108; Zenithrad part/dwg No. 93G3097.	Jack - mounting insulating washer.	3G100-306
E10	INSULATOR, plate: bakelite, PBE, brown; fungusproofed finish; flat oval shape, MBCA ref dwg group 9, item code No. 220, MBCA ref dwg group 9, dimen MBCA ref dwg group 9, W—1-17/32", L—2-3/16", two .135" mtg holes spaced 1-13/32" c to c; Zenithrad part/dwg No. 78G3021.	Insulator for electrolytic capacitors, C45A, C45B, C45C, C45D.	3G320-367
J3	JACK, telephone: for 2 cond plug; shank, 3/8" dia x 5/16" lg; cont arrangement J4-1B; 1 spring; 1-1/4" lg x 1" wd x 1-1/8" h o/a; 3/8" dia mtg hole required; mtg accessories c/o 1 ins bushing, 1 hex. nut, 1 washer; tropic-proofed; JAN spec No. JAN-J-641 type JJ-089; Switchcraft, Inc. part No. JJ089; Zenithrad part/dwg No. 44G3004.	To adapt receiver to use of earphones.	2Z5598A-89
O 3, O 4	KNOB: round, tenite, brown; accom 1/4" dia round shaft, 7/8" d shaft hole, friction mtd by slotted shaft; 15/16" lg x 15/16" dia o/a; 5/8" dia roman gold disk on front of knob; Zenithrad part/dwg No. 46G3013.	O 3: Tuning knob. O 4: Volume control knob.	2Z5822-797

## 2. Identification Table of Parts for Radio Receiver R-520/URR (cont'd)

Ref. symbol	Name of part and description	Function of Part	Signal Corps stock No.
O 5, O 6, O 7, O 8, O 9, O 10, O 11	KNOB: rectangular, tenite, brown; 13/16" lg x 17/32" wd x 13/16" h o/a; loosely coupled, direct cont push button type; Zenithrad part/dwg No. 46G3012.	O 5: Band switching knob, standard broadcast band. O 6: Band switching knob, 4-8 mc. O 7: Band switching knob, 2-4 mc. O 8: Band switching knob, 17.4-18.2 mc. O 9: Band switching knob, 14.8-16.6 mc. O 10: Band switching knob, 11.5-12.1 mc. O 11: Band switching knob, 9.4-9.8 mc.	2Z5822-798
I 1	LAMP, glow: 1/25 w, 65 v ac striking voltage, 90 v dc striking voltage; lamp data, MBCA ref dwg group 7, miniature bayonet base; T-3 1/4 bulb, clear, orange; 1 1/8" max o/a h; over 25 hours rated life; any burning position; neon gas; ext resistance required, 100,000 ohms for 105-125 v operation; GE Lamp Div type No. NE51, Zenithrad part/dwg No. 100G3052.	On-off indicator.	2Z5888-5
A 6	LATCH, fastener: steel, cad pl w/clear iridite; 1 3/8" lg o/a x 1" wd; used to prevent back cabinet cover from opening while carrying cabinet; 2 holes, screw mtd, 5/8" mtg/c; Amer Cabt Hdwe part No. 3675.	Back door latch.	6Z6917-10

O 67	LATCH, fastener: roman gold finish, 4" lg x 1-17/32" wd x 11/32" d; depressed blk lettering .015" d; upper half of two sect., incl latch lock w/engaging action w/lower sect.; two No. 6-32 tap holes on 3-1/8" mtg/c; Zenithrad part/dwg No. 156G3001.	Door fastener.	6Z6917-11
O 68	CATCH, fastener: roman gold finish; 3-5/8" lg x 1/2" wd x 11/32" d; depressed blk lettering .015" d; lower half of two sect., 17/32" x 9/32" slot for lock engagement; two No. 6-32 tap holes on 3-1/8" mtg/c; Zenithrad part/dwg No. 156G3002.	Door fastener.	6Z1747-65
X11	LIGHT, panel; 1 lamp, miniature bayonet base, 105 v to 125 v, GE type No. NE-51; no lamp incl; steel shell and mtg bkt; cad pl w/clear iridite; brk mtd, on flange, on rear of panel; 1" lg shell plus 12" ins leads; 29/64" dia; 2 wire lead term. located on socket base; tropic-proofed; Zenithrad part/dwg No. 78G3026.	Socket and bracket for glow lamp.	2Z5991-327
LS1	LOUDSPEAKER, dynamic: permanent magnet field; 3.2 ohms voice coil impedance; .3 w input normal, 1 w peak; cone type, 5-1/4" dia of cone; output transf incl, 8000 ohms pri impedance; 5-1/2" h x 5-1/4" wd x 3-3/4" d o/a; four corner mtg holes spaced equally on 2 13/16" rad circle; incl gasket assy; baffle 5-1/4" x 5 1/4", 1/8" of thk duron eyeleted to speaker frame; ctr opening equivalent to 4 5/8" dia; 2 piece blk sponge rubber gasket 5-1/4" x 5-1/4" x 1 3/32" wd x 1/8" thk, pieces cemented to ea other and then cemented to baffle board; built in feedback wdg; Zenithrad part/dwg No. SG6612.	Converts electrical energy of audio frequency into audible sound energy.	6843-190
H1	NUT, plain, knurled; brass; clear lacquer finish; No. 6-32 thd, NCT, class 2 fit; 5/8" dia x 3/8" lg o/a; Zenithrad part/dwg No. 54G3064.	Loop mounting nut.	6L3406-32-10K

## 2. Identification Table of Parts for Radio Receiver R-520/URR (contd)

Ref. symbol	Name of part and description	Function of Part	Signal Corps stock No.
H2	NUT, plain, knurled: brass; clear lacquer finish; No. 10-32 thd, NCT, class 2 fit; $\frac{5}{8}$ " dia x $\frac{3}{8}$ " lg o/a; Zenithrad part/dwg No. 54G3065.	Loop mounting nut.	6L3410-32K1
H6	POST, stud: SS; 2- $\frac{5}{8}$ " lg; 1/32" x 45° chamfer at both ends; No. 8-32, NCT; Accurate Threaded Fasteners, Inc. part No. 25.	Mounting stud for thermal resistor tube clamp.	2Z7259-256
O 66	PULLEY, single groove: steel, cad pl and clear iridite finish; 2- $\frac{1}{8}$ " dia, .251" dia extruded ctr hole, .096" dia hole 11/16" from ctr hole at top for dial cord admittance, $\frac{1}{4}$ " thk pulley; shaft, steel, cad pl and clear iridite finish; 1-11/16" lg, .250" dia, straight med knurl 5/16" lg and 17/32" from end; Zenithrad part/dwg No. SG6644.	Method of rotating dial pointer.	2Z7334-15
CR1	RECTIFIER, metallic: selenium; for single ph half-wave circuit, MBCA Ref Dwg Group 23; 117 v ac input, single ph; 130 v dc max output, 100 ma, half-wave; sq shape, 1" lg x 1- $\frac{1}{8}$ " wd x 1-13/32" d; 1 clearance hole for No. 6 mach screw for mtg; 2 solder lug term. located one at ea end; fungi proofed; Sarkes Tarzian Co. part No. 2 SR-641-RVM.	AC rectifier.	3H4860-251
CR2	RECTIFIER, metallic: selenium; for single ph halfwave circuit, MBCA Ref Dwg Group 23; 117 v ac input, single ph; 130 v dc max output, 75 ma max current, half wave rectification; sq shape; 1" lg x $\frac{1}{2}$ " wd x 1" h; excluding term.; 1 clearance hole for No. 6 mach screw for mtg;	A C rectifier.	3H4860-252

R24	2 solder lug term. located one at end; fungiproofed; Sarkes Tarzian Co. part No. 2 SR-2H1-RVM. RESISTOR, fixed; comp; 4.7 ohms $\pm 10\%$ ; 1 w; F characteristic; body, excluding term., .37/.64" lg x 7-.32" dia; 2 axial wire lead term. spec No. JAN-R-11; AB part No. GB-47G1; Zenithrad part/dwg No. 63G3758.	R-f suppressor (2-4 mc and 4-8 mc).	3Z5994G7-5
R5, R37	RFSISTOR, fixed; comp; 100 ohms $\pm 10\%$ ; 1/2 w; F characteristic; body, excluding term., .468" lg x .249" dia; 2 axial wire lead term., Spec. No. JAN-R-11, Spec type No. RC20BF101K.	R5: Converter filament balancer. R37: Battery surge suppressor.	3RC20BF101K
R11	RESISTOR, fixed; comp; 120 ohms $\pm 10\%$ ; 1/2 w; F characteristic; body, excluding term., .468" lg x .249" dia; 2 axial wire lead term.; spec No. JAN-R-11, spec type No. RC20BF121K.	I-f amplifier filament balancer.	3RC20BF121K
R8, R25	RESISTOR, fixed; comp; 150 ohms $\pm 10\%$ ; 1/2 w; F characteristic; body, excluding term., .468" lg x .249" dia; 2 axial wire lead term.; spec No. JAN-R-11, spec type No. RC20BF151K.	R8: R-f and detector filament balancer. R25: Converter grid suppressor (2-4 mc).	3RC20BF151K
R23	RESISTOR, fixed; comp; 270 ohms $\pm 10\%$ ; 1/2 w; F characteristic; body, excluding term., .468" lg x .249" dia; 2 axial wire lead term.; spec No. JAN-R-11, spec type No. RC20BF271K.	Audio output filament balancer.	3RC20BF271K
R36	RESISTOR, fixed; comp; 560 ohms $\pm 10\%$ ; 1/2 w; F characteristic; body, excluding term., .468" lg x .249" dia; 2 axial wire lead term.; spec No. JAN-R-11 spec type No. RC20BF561K.	B+ supply filter.	3RC20BF561K
R12	RESISTOR, fixed; comp; 1000 ohms $\pm 10\%$ ; 1/2 w; F characteristic; body, excluding term., .468" lg x .249" dia; 2 axial wire lead term.; spec No. JAN-R-11. spec type No. RC20BF102K.	I-f amplifier plate decoupler.	3RC20BF102K

## 2. Identification Table of Parts for Radio Receiver R-520/URR (contd)

Ref. symbol	Name of part and description	Function of Part	Signal Corps stock No.
R32	RESISTOR, fixed; comp; 1500 ohms $\pm 10\%$ ; $\frac{1}{2}$ w; F characteristic; body, excluding term., .468" lg x .249" dia; 2 axial wire lead term.; spec No. JAN-R-11, spec type No. RC20BF152K.	Tone control.	3RC20BF152K
R1	RESISTOR, fixed; comp; 2200 ohms $\pm 20\%$ ; $\frac{1}{2}$ w; F characteristic; body, excluding term., .468" lg x .249" dia; 2 axial wire lead term.; spec No. JAN-R-11, spec type No. RC20BF222M.	Antenna match.	3RC20BF222K
R4	RESISTOR, fixed; comp; 3300 ohms $\pm 20\%$ ; $\frac{1}{2}$ w; F characteristic; body, excluding term., .468" lg x .249" dia; 2 axial wire lead term.; spec No. JAN-R-11, spec type No. RC20BF332M.	Detector, oscillator, and screen supply B filter.	3RC20BF332K
R3	RESISTOR, fixed; comp; 15,000 ohms $\pm 20\%$ ; $\frac{1}{2}$ w; F characteristic; body, excluding term., .468" lg x .249" dia; 2 axial wire lead term.; spec No. JAN-R-11, spec type No. RC20BF153M.	R-f plate load damper.	3RC20BF153K
R34	RESISTOR, fixed; comp; 18,000 ohms $\pm 10\%$ ; $\frac{1}{2}$ w; F characteristic; body, excluding term., .468" lg x .249" dia; 2 axial wire lead term.; spec No. JAN-R-11, spec type No. RC20BF183K.	Tone control.	3RC20BF183K
R35	RESISTOR, fixed; comp; 27,000 ohms $\pm 10\%$ ; $\frac{1}{2}$ w; F characteristic; body, excluding term., .468" lg x .249" dia; 2 axial wire lead term.; spec No. JAN-R-11, spec type No. RC20BF273K.	Tone control.	3RC20BF273K



R7	RESISTOR, fixed: comp; 68,000 ohms $\pm 20\%$ ; $\frac{1}{2}$ w; F characteristic; body, excluding term., .468" lg x .249" dia; 2 axial wire lead term.; spec No. JAN-R-11, spec type No. RC20BF683K.	Converter screen dropper.	3RC20BF683K
R6, R31, R33	RESISTOR, fixed: comp; 100,000 ohms $\pm 10\%$ ; $\frac{1}{2}$ w; F characteristic; body, excluding term., .468" lg x .249" dia; 2 axial wire lead term.; spec No. JAN-R-11, spec type No. RC20BF104K.	R6: Oscillator grid leak. R31: Neon lamp limiter. R33: Tone control.	3RC20BF104K
R28	RESISTOR, fixed: comp; 220,000 ohms $\pm 20\%$ ; $\frac{1}{2}$ w; F characteristic; body, excluding term., .468" lg x .249" dia; 2 axial wire lead term.; spec No. JAN-R-11, spec type No. RC20BF224K.	B+ supply bleeder.	3RC20BF224K
R29	RESISTOR, fixed: comp; 330,000 ohms $\pm 20\%$ ; $\frac{1}{2}$ w; F characteristic; body, excluding term., .468" lg x .249" dia; 2 axial wire lead term.; spec No. JAN-R-11, spec type No. RC20BF334K.	B- to chassis isolation.	3RC20BF334K
R2, R16, R20, R22, R26	RESISTOR, fixed: comp; 1 meg $\pm 20\%$ ; $\frac{1}{2}$ w; F characteristic; body, excluding term., .468" lg x .249" dia; 2 axial wire lead term.; spec No. JAN-R-11, spec type No. RC20BF105K.	R2: R-f grid return. R16: Volume control shunt. R20: Audio output grid return. R22: Detector plate load. R26: Converter grid return.	3RC20BF105K
R9, R15	RESISTOR, fixed: comp; 2.2 meg $\pm 20\%$ ; $\frac{1}{2}$ w; F characteristic; body, excluding term., .468" lg x .249" dia; 2 axial wire lead term.; spec No. JAN-R-11, spec type No. RC20BF225K.	R9: Avc network bleeder. R15: Avc network divider.	3RC20BF225K
R14, R21	RESISTOR, fixed: comp; 4.7 meg $\pm 20\%$ ; $\frac{1}{2}$ w; F characteristic; body, excluding term., .468" lg x .249" dia; 2 axial wire lead term.; spec No. JAN-R-11, spec type No. RC20BF475K.	R14: Avc network divider. R21: Detector screen dropper.	3RC20BF475K

## 2. Identification Table of Parts for Radio Receiver R-520/URR (contd)

Ref. symbol	Name of part and description	Function of Part	Signal Corps stock No.
R10	RESISTOR, fixed: comp; 5.6 meg $\pm 10\%$ ; $\frac{1}{2}$ w; F characteristic; body, excluding term., .468" lg x .249" dia; 2 axial wire lead term.; spec No. JAN-R-11, spec type No. RC20BF565K.	Avc network bleeder.	3RC20BF565K
R13, R19	RESISTOR, fixed: comp; 10 meg $\pm 20\%$ ; $\frac{1}{2}$ w; F characteristic; body, excluding term., .468" lg x .249" dia; 2 axial wire lead term.; spec No. JAN-R-11, spec type No. RC20BF106K.	Avc network dividers.	3RC20BF106K
R18	RESISTOR, fixed: comp; 15 meg $\pm 20\%$ ; $\frac{1}{2}$ w; F characteristic; body, excluding term., .468" lg x .249" dia 2 axial wire lead term.; spec No. JAN-R-11, spec type No. RC20BF156K.	Detector grid return.	3RC20BF156K
R27	RESISTOR, fixed: WW noninductive wdg; 130 ohms $\pm 5\%$ ; 4.5 w; body, excluding term., 1" lg x 19/32" OD; vitreous enamel coated; 2 solder lug term.; 21/64" wd x $\frac{1}{4}$ " lg; bolt mtd; Jan spec No. JAN-R-26A, except for value; Ohmite type No. 1W30J131.	Rectifier filter and limiter.	3Z6013-21
R30	RESISTOR, fixed: WW; noninductive wdg; 680 ohms $\pm 5\%$ ; tol 4.5 w; body, excluding term., 1" lg x 19/32" OD; vitreous enamel coated; 2 solder lug term., 21/64" wd x $\frac{1}{4}$ " lg; bolt mtd; Jan spec No. JAN-R-26A, except for value; Ohmite type No. IN30J681.	Filament supply filter.	3Z6068-22
R38A, R38B	RESISTOR, fixed: WW; body style No. 42, MBCA ref dwg group 2; noninductive wdg; 620 ohms one sect.,	Dropping resistor for 220-volt operation.	3Z6062-20

RT1	<p>1200 ohms secd sect.; <math>\pm 10\%</math> ea sect. and <math>\pm 10\%</math> secd sect.; 15 w first sect., 7 w 1 tap, 620 ohms, 1200 ohms between tap; body, excluding term., 2" lg x <math>\frac{5}{8}</math>" OD; vitreous enamel coated; 3 wire lead term., 2" lg; bolt mtd; Ohmite part No. 35060.</p> <p>RESISTOR, thermal: 833 ohms nom, 80° C ambient temp; 54 ma nom oper current, 3-<math>\frac{1}{4}</math> w, 58 ma max oper current, 35 v working range; for dc use; ballast-tube type, T-6 <math>\frac{1}{2}</math>-bulb, 2-<math>\frac{5}{8}</math>" o/a lg including cont; 9 pin miniature base for socket mtg; tube marked MJ051T; Amplex Electronics Products, Inc. type No. MJ051T; Zenithrad part/dwg No. 100G3051.</p>	Current regulator.	3Z6925-13
R17	<p>RESISTOR, variable: comp; 1 meg <math>\pm 30\%</math>; <math>\frac{1}{4}</math> w; 3 solder lug term.; metal case, inclosed, dimen, including all sect. and sw, 15/16" dia of body, 1-27/32" d; metal shaft, knurled, slotted 1/16" wd and 33/64" d, .250" dia, 29/32" lg from mtg surface; ins cont arm, off position, ccw end of rotation; mtd by bushing, <math>\frac{3}{8}</math>" dia, 32 thd per inch, <math>\frac{1}{4}</math>" lg; DPST sw, 3 amp, 125 v ac; normally open, operates at start of rotation; 4 solder lug term.; Jan spec No. Jan-R-94, except for resistance taper and shaft knurl; CTS part No. SL-7838.</p>	Volume control.	3Z7499-1.169
O 63	<p>SHAFT, tuning: steel; cad pl and clear iridite; 1-<math>\frac{3}{8}</math>" lg x <math>\frac{1}{4}</math>" dia o/a; one end slotted 1/16" wd x 33/64" d; on slotted end, shaft is knurled 23/64" lg, <math>\frac{1}{8}</math>" rad groove 1-5/64" from slotted end to accom dial cord, .028" wd x .147" dia groove for mtg purposes; single spring clip in .028" wd x .147" dia groove for mtg; Zenithrad part/dwg No. 76G3034.</p>	Drive shaft for Tuning R-520/URR.	2Z8203-746

## 2. Identification Table of Parts for Radio Receiver R-520/URR (contd)

Ref. symbol	Name of part and description	Function of Part	Signal Corps stock No.
O 72	SHELL, electrical connector: steel, cad pl and clear iridite finish; cylindrical shape; $\frac{5}{8}$ " lg x 1" dia o/a; crimp mtd; one .375" hole for cable insertion; used as retainer for plug Cinch part No. 16B11695-P88.	Retaining cap.	2Z8276-105
O 71	SHELL, electrical connector: steel, cad pl and clear iridite finish; cylindrical shape; $\frac{63}{64}$ " lg x $\frac{59}{64}$ " dia o/a; crimp mtd; used as battery socket cap; Cinch part No. 7059.	Retains battery socket insert.	2Z8276-106
E5, E6, E7, E8, E9	SHIELD, electron tube: copper or brass; cylindrical shape; 1- $\frac{3}{4}$ " lg x 1" (approx) o/a; lock mtd to socket shield; Jan spec No. JAN-S-28A, Amendment No. 1; spec type No. TS102U02; Eby part No. 9701-20; Zenithrad part/dwg No. 126G3062.	E5: Tube shield V1. E6: Tube shield V2. E7: Tube shield V3. E8: Tube shield V4. E9: Tube shield V5.	2Z8304.276
XRT1	SOCKET, electron tube: 9 cont, beryllium copper, silver pl; miniature size; incl metal shock shield, .940" dia x $\frac{5}{8}$ " h; incl ctr shield .18" dia; oval shape; 1- $\frac{3}{8}$ " lg x 15/16" wd x 25/32" h o/a; round plastic body; one piece saddle mtg, .750" dia hole, 2 mtg holes, .125" dia x 1.125" spacing c to c; JAN spec No. JAN S-28A, Amendment No. 1, spec type TS103P01; Cinch part No. 53F13373; Zenithrad part/dwg No. 78G3028.	Tube socket for RT1.	2Z8679.30
XV1 thru XV5	SOCKET, electron tube: 7 cont, beryllium copper, silver pl; miniature size; incl metal shock shield, .800" dia x $\frac{5}{8}$ " lg; incl ctr shield, .18" dia; oval shape; 1- $\frac{1}{8}$ " lg x 27/32" wd x 25/32" h o/a; round plastic body; one piece saddle	XV1: Tube socket for V1. XV2: Tube socket for V2. XV3: Tube socket for V3. XV4: Tube socket for V4.	2Z8677.94

O 40, O 41	mtg, .640" dia hole, 2 mtg holes .125" dia, spaced .875" c to c; JAN spec No. JAN S-28A, Amendment No. 1; spec No. TS102P01; Eby part No. 9735-11. SPRING, dial cord tension: music wire, No. 24 gauge; cad pl w/clear iridite finish; 25/32" lg (approx) x 15/64" dia x 1/16" gap at both ends; heat treated after plating; Zenithrad part/dwg No. 80G3075.	XV5: Tube socket for V5.  Dial cord tension spring.	2Z8878-97
O 17	PAD, silencing: felt, blk finish; 4-15/32" lg x 1" wd x 1/16" thk; mtg data seven rectangular slots, into which push button knobs are inserted, 3/8" lg x 11/32" wd; located 3/16" from edge and are approx 3/8" apart; used to provide silencing and cushioning action for push button knobs; located on inside of cabinet; Zenithrad part/dwg No. 83G3134.	Provides cushioning and silencing for bandswitch knobs.	6Z7475
O 15, O 16	CUP, suction: suction cup w/socket, cup shaped, rubber material, grade RN500; 1" dia tapered to 7/32" dia; centrally vulcanized to brass rivet, in turn staked to nickel pl snap fastener socket; 5/32" h; .420" dia; socket data; .015 brass, No. 2 hardness, nickel pl; Zenithrad part/dwg No. SG6619.	O 15: To allow distant mounting of loop antenna within limits of loop extension cable. O 16: Part of suction cup assembly.	2Z3590-8
S2A, S2B, S2C, S2D	SWITCH ASSEMBLY: 4 sw, slide, ac, 125 V, .75 amp ea; 8 solder lug term, located on back; steel case, bakelite ins; SPST; 4-7/16" lg x 17/32" wd x 1-1/32" d o/a; two .156" dia mtg holes spaced 11-1/16" c to c; fungiproofed; Muter part No. 10672; Zenithrad part/dwg No. 85G3022.	Tone control.	3Z9903A-34.1
S1A, S1B, S1D, S1E, S1F,	SWITCH, push: 7 units; 13 stator cont, unit 1; 16 stator cont, unit 3; 16 stator cont, unit 4; 23 stator cont, unit 5; 23 stator cont, unit 6; 19 stator cont, unit 7; locking action, locks w/latch bars; metal body and phenolic stators; o/a dimen excluding term. and actuating slides,	Bandswitch.	3Z9824-60.6

## 2. Identification Table of Parts for Radio Receiver R-520/URR (contd)

Ref. symbol	Name of part and description	Function of Part	Signal Corps stock No.
S1G	2- $\frac{3}{4}$ " lg x 1-5/32" wd x 5-21/32" h; external actuator data, plunger with knob 9/16" lg; 93 solder lug term. located on stator sides; three No. 6-32 tapped mtg holes spaced 2- $\frac{3}{8}$ " c to c and 3" c to c; fungiproofed; Oak part No. 50716-130; Zenithrad part/dwg No. 85G3021.		
S4	SWITCH, slide: triple-pole, double-throw; .5 amp, 125 v; bakelite body, dimen, excluding term.; 1- $\frac{7}{8}$ " lg x 17/32" wd x 15/32" h; slide button actuator, 9/32" lg x 7/32" wd; nonlocking; 9 solder lug term.; flush mtg two .125" dia holes spaced 1.625" c to c; fungiproofed; Stackpole part No. SS6.	A-c battery change-over switch.	3Z9835-1.7
S5	SWITCH, slide: 3 position sw; 125 V, .75 amp; bakelite, dimen, excluding term.; 1- $\frac{3}{8}$ " lg x 17/32" wd x .47875" h; slide button actuator, 9/32" lg x 3/16" h; locking action; 4 solder lug term.; flush mtg, two extruded and tapped No. 4-40 mtg holes spaced 1.125" c to c; cad pl w/clear iridite, fungiproofed; Stackpole part No. SS7.	Voltage adapter switch.	3Z9835-1.6
TB1	TERMINAL BOARD: bakelite board, 1 solder lug term.; w/o barriers; 1" lg x $\frac{3}{8}$ " wd x $\frac{1}{2}$ " d o/a; one mtg foot w/one .140" dia hole for mtg; term. hot tin dipped, cinch lug cad pl and clear iridite; Cinch part No. 18A-18070.	Wiring terminal.	3Z770-1.41
TB2	TERMINAL BOARD: molded phenolic board; 3 solder lug term.; w/o barriers; 1 $\frac{1}{2}$ " lg x 21/32" wd x $\frac{1}{2}$ " thk o/a; one mtg foot w/one .140" dia hole; fungiproofed, term.	Wiring terminal.	3Z770-3.97

TB3	<p>hot tin dipped, mtg foot hot tin dipped; Alcon Metal Corp. part No. T-4-1162 XXV.</p> <p>TERMINAL BOARD: molded phenolic board; 4 solder lug term.; w/o barriers; 1-<math>\frac{7}{8}</math>" lg x 21/32" wd x <math>\frac{1}{2}</math>" thk o/a; one mtg foot w/one .140" dia hole; fungiproofed, term. and mtg feet hot tin dipped; Zenithrad part/dwg No. 83G3129.</p>	Wiring terminal.	3Z770-4.169
TB4	<p>TERMINAL BOARD: PBE bakelite board; 2 solder lug term.; w/o barriers; 1-<math>\frac{1}{8}</math>" lg x 21/32" wd x <math>\frac{1}{2}</math>" d o/a; one mtg foot w/one .140" dia hole; fungiproofed, term. and mtg feet hot tin dipped; Zenithrad part/dwg No. 83G3143.</p>	Wiring terminal.	3Z770-2.155
TB6	<p>TERMINAL BOARD: molded phenolic board; 5 solder lug term.; w/o barriers; 2-27/32" lg x 1-<math>\frac{1}{2}</math>" wd x <math>\frac{1}{8}</math>" thk o/a; two .156" dia mtg holes spaced 2-<math>\frac{1}{2}</math>" c to c fungiproofed; Zenithrad part/dwg No. SG6607.</p>	R-f terminal board.	3Z770-5.79
TB7	<p>TERMINAL BOARD: NPG phenolic board; 3 term., 2 solder lug type w/ No. 6-32 captivated Bind H screws <math>\frac{3}{8}</math>" lg and one pin jack term.; w/o barriers; 1-29/32" lg x <math>\frac{5}{8}</math>" wd x 21/32" d o/a; two .125" dia holes spaced 1.218" c to c; fungiproofed; Zenithrad part/dwg No. 83G3124.</p>	Antenna connector.	3Z770-3.98
T3	<p>TRANSFORMER, AF: pl coupling type; 8000 ohms pri, 3.2 ohms secd; pri rated 7 ma dc; open frame steel case, silicon steel core; 2" lg x 1-<math>\frac{1}{2}</math>" wd x 1-11/16" h o/a; 1 w; 50 to 1 ration of turns, pri to secd; 100 cyc to 5000 cyc per sec; seven flexible wire term. located on sides; 2 mtg holes 3/16" dia, spaced 2-<math>\frac{3}{8}</math>" c to c; feedback wdg; Zenithrad part/dwg No. 95G3036.</p>	To match the impedance of output tube to speaker.	2Z9632.756

## 2. Identification Table of Parts for Radio Receiver R-520/URR (contd)

Ref. symbol	Name of part and description	Function of Part	Signal Corps stock No.
T1	<p>TRANSFORMER, IF: 455 kc; input; 1-3/16" lg x 1-3/16" wd x 2-9/16" h o/a; bakelite coil form; powdered iron core; double tuned; adj iron core tuned; mtd by 2 spade bolts spaced 1.206" c to c; 4 solder lug term.; tropicalized; Rollan Electric Co. part No. 0-5095.</p>	First i-f transformer.	2Z9631.486
T2	<p>TRANSFORMER, IF: 455kc; output; shielded; 1-3/16" lg x 1-3/16" wd x 2-9/16" h o/a; bakelite coil form; powdered iron core; double tuned; adj iron core tuned; mtd by 2 spade bolts; spaced 1.206" c to c; 6 solder lug term.; tropicalized; Rollan Electric Co. part No. 0-5096.</p>	Second i-f transformer.	2Z9632.757
L1	<p>TRANSFORMER, RF: 2 universal wdg; inductance; pri, 177.5 uh at 1000 cyc, secd, 179.6 uh at 1000 cyc; turns and wire size, pri, 91 turns No. 36 AWG single celanese enameled copper wire; secd 95 turns 7 strand No. 41 AWG single celanese enameled copper wire; dc resistance, pri .7 ohms, secd; .013 ohms; untuned; unshielded; 19/64" lg coil o/a x 59/64" dia bakelite coil form, air core; spring tension clip mtg; 4 solder lug term.; located on outside of coil form; red identification code III stamped on coil form; white lacquer spotted; wax impregnated; Zenithrad part/dwng No. SG6529.</p>	Detector coil assembly, broadcast band.	2Z962665
L2	<p>TRANSFORMER, RF: 4 wdg, pri No. 1, universal wdg; secd No. 1, universal wdg; pri No. 2, solenoid wdg; secd No. 2, spaced solenoid wdg; inductance, pri No. 1, 47.7 uh at 1000 cyc; secd No. 1, 97.5 uh at 1000 cyc; pri No.</p>	Oscillator coil assembly for broadcast band.	2Z9626.66



2, 1.2 uh at 1000 cyc; secd No. 2, 4 uh at 1000 cyc; pri No. 1, 50 turns of 3 strands No. 41 AWG single celanese, enameled copper wire; secd No. 1, 72 turns of 3 strands No. 41 AWG single celanese, enameled copper wire; pri No. 2, 5-3/4 turns No. 38 AWG single celanese, enameled copper wire; secd No. 2, 6 turns No. 22 AWG plastic, enameled copper wire; dc resistance pri 3.2 ohms, secd, 8.2 ohms; unshielded; 2-1/16" lg o/a x 3/4" dia excluding term.; bakelite coil form; spring tension clip; 8 solder lug term.; located outside coil form; coil stamped B2 at bottom of coil form wax impregnated; Zenithrad part/dwg No. SG6528.

L18A,  
L18B

TRANSFORMER, RF: 2 wdg, close-wound solenoid; inductance: pri 2.8 uh at 1000 cyc per sec, secd 4.7 uh at 1000 cyc per sec; turns and wire size: pri, 18 turns No. 26 AWG copper wire, secd, 15-1/3 turns No. 36 AWG copper wire; dc resistance: pri, .084 ohms, secd, .809 ohms; unshielded; 25/64" lg x 29/64" dia; cosmolute form, iron core; coil form, 1-7/8" lg x .375" dia o/a; adj iron core, tuning wrench adj, inside coil form at one end; clip mtd; 3 staple type term.; fungiprofed; Zenithrad part/dwg No. SG6544.

2Z9626.67

L18A: Primary oscillator coil assembly, 4-8 mc.  
Secondary oscillator coil assembly, 4-8 mc.

L19A,  
L19B

TRANSFORMER, RF: 2 wdg, close wound solenoid; inductance: pri, 10 uh at 1000 cyc per sec, secd, 3.7 uh at 1000 cyc per sec; turns and wire size: pri, 31 turns No. 30 AWG copper wire, secd, 14-1/3 turns No. 36 AWG copper wire; dc resistance: pri, .362 ohms, secd, .717 ohms; unshielded; 25/64" lg x 29/64" dia; cosmolute form, iron core; coil form, 1-7/8" lg x .375" dia. o/a; adj iron core, tuning wrench adj; inside coil form at one end;

2Z9626.68

L19A: Secondary oscillator coil, 2-4 mc.  
L19B: Primary oscillator coil, 2-4 mc.

150 2. Identification Table of Parts for Radio Receiver R-520/URR (contd)

Ref. symbol	Name of part and description	Function of Part	Signal Corps stock No.
O 61, O 62	clip mtd, 3 staple type term.; fungiproofed; Zenithrad part/dwg No. SG6545. WASHER, key: steel, cad pl; 1 key on inner edge; .335" OD, .025" thk, .145" ID; Diebel Die & Mfg. Co. Zenithrad part/dwg No. 188G3022.	Shaft retainer.	2Z7858-154
O 14	TOOL, alinement: nylon; natural color; screwdriver shaped blade at one end 1/32" thk x 5/64" wd; other end hex. shaped .099" regular hex.; 5" lg x 1/4" dia o/a; ctr portion fluted for handle grip; used to adj iron cores in r-f coils; Zenithrad part/dwg No. 68G3012.	Iron core adjustment, r-f coils and i-f transformers.	6Q336-1

RESISTOR COLOR AND LETTER CODE

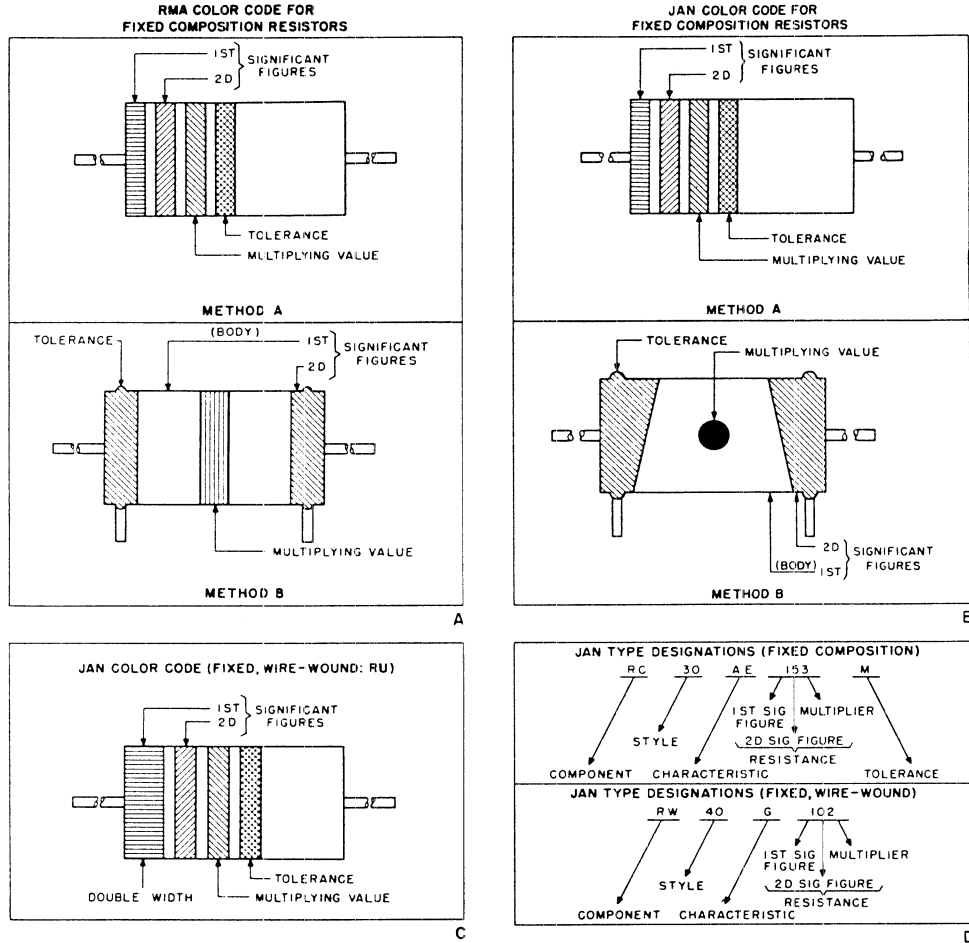

STANDARDS				
COLOR	SIGNIFICANT FIGURE	MULTIPLYING VALUE	TOLERANCE (%)	JAN LETTER TOLERANCE
BLACK	0	1	—	—
BROWN	1	10	± 1	F
RED	2	100	± 2	G
ORANGE	3	1,000	± 3	—
YELLOW	4	10,000	± 4	—
GREEN	5	100,000	± 5	—
BLUE	6	1,000,000	± 6	—
VIOLET	7	10,000,000	± 7	—
GRAY	8	100,000,000	± 8	—
WHITE	9	1,000,000,000	± 9	—
GOLD	—	0.1	± 5	J
SILVER	—	0.01	± 10	K
NO COLOR	—	—	± 20	M

- NOTES:
- RESISTORS WITH AXIAL LEADS ARE INSULATED. RESISTORS WITH RADIAL LEADS ARE NON-INSULATED.
  - RMA: RADIO MANUFACTURERS ASSOCIATION.
  - JAN: JOINT ARMY - NAVY.
  - THESE COLOR AND NUMBER CODES GIVE ALL RESISTANCE VALUES IN OHMS.
  - RESISTIVE COMPONENTS USED FOR LETTER TOLERANCES ARE: RC, RN, AND RU.
  - WATTAGE FOR RW TYPES IS FOUND IN THE JAN SPECIFICATIONS UNDER CHARACTERISTICS.

TMRC

Figure 38. Resistor color codes.

### CAPACITOR COLOR AND LETTER CODES

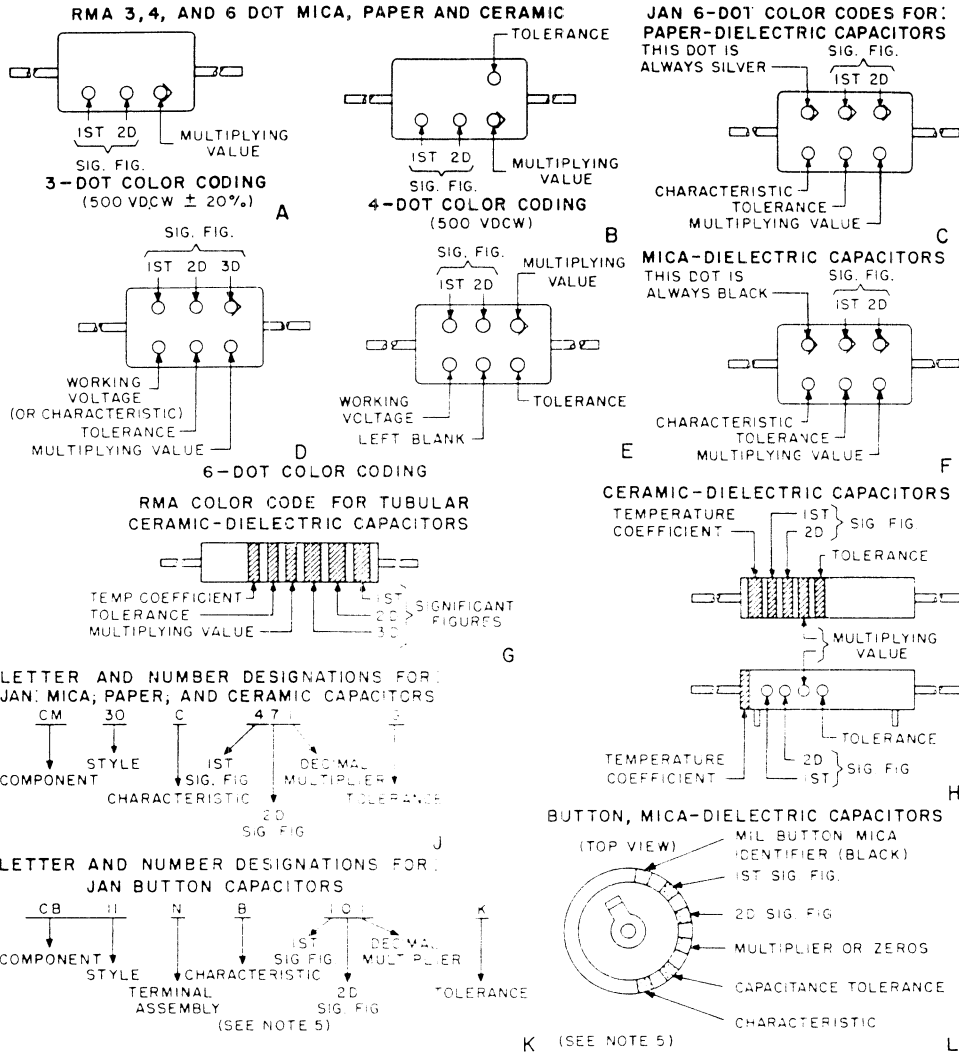

- STANDARDS -					JAN MICA-CM		JAN PAPER-CN		JAN CERAMIC-CC					
COLOR	SIG. FIG.	DECIMAL MULTIPLIER	% TOL.	VDCW	LETTER	CHARAC-TERISTIC	LETTER	CHARAC-TERISTIC	DEC. MULT.	%	LETTER DESIGN-NATION	UUF	LETTER DESIGN-NATION	CHARAC-TERISTIC
BLACK	0	1	±20	500	M	A	M	A	1	±20	M	±2.0	G	C
BROWN	1	10	±1	100	-	B	-	E	10	±1	F	-	-	H
RED	2	100	±2	200	G	-	-	H	100	±2	G	-	-	L
ORANGE	3	1,000	±3	300	-	D	N*	J	1,000	-	-	-	-	P
YELLOW	4	10,000	±4	400	-	E	-	P	-	-	-	-	-	R
GREEN	5	100,000	±5	500	-	F	-	R	-	±5	J	±0.5	D	S
BLUE	6	1,000,000	±6	600	-	-	-	S	-	-	-	-	-	T
VIOLET	7	10,000,000	±7	700	-	-	-	T	-	-	-	-	-	U
GRAY	8	100,000,000	±8	800	-	-	-	-	0.01	-	-	±0.25	C	B
WHITE	9	1,000,000,000	±9	900	-	-	-	-	0.1	±10	K	±1.0	F	Q
ROSD	-	0.1	±5	1,000	J	-	-	-	-	-	-	-	-	A
SILVER	-	0.01	±10	2,000	K	-	K	-	-	-	-	-	-	-
NO COLOR	-	-	±20	500	-	-	-	-	-	-	-	-	-	-

\* THE TOLERANCE OF THIS CAPACITOR IS ±30%, NOT ±25%

NOTES

- JAN: JOINT ARMY-NAVY
- RMA: RADIO MANUFACTURERS ASSOCIATION
- 1. THESE COLOR AND LETTER CODES GIVE CAPACITANCES IN MICROMICROFARADS
- 2. THIS TABLE IS ADAPTED FOR JAN AND RMA COLOR AND JAN LETTER TYPE DESIGNATIONS
- 3. CERAMIC AND MICA CAPACITORS, BOTH JAN AND RMA, ARE GENERALLY 500 VDCW
- 4. BUTTON CAPACITORS ARE GENERALLY 300 VDCW
- 5. READ BUTTON CAPACITOR TOLERANCE UNDER CERAMICS OF MORE THAN 10 UUF
- 6. CHARACTERISTICS ARE AVAILABLE IN JAN CAPACITOR SPECIFICATION MANUALS
- 7. THE COMPONENTS USED ABOVE FOR JAN LETTER TYPE DESIGNATIONS ARE:  
 CB MICA BUTTON; CC CERAMIC; CM MICA MOULDED; CN PAPER MOULDED

TM CC

Figure 39. Capacitor color codes.

R-F AMPL  
V1  
1U4

CONVERTER  
V2  
1L6

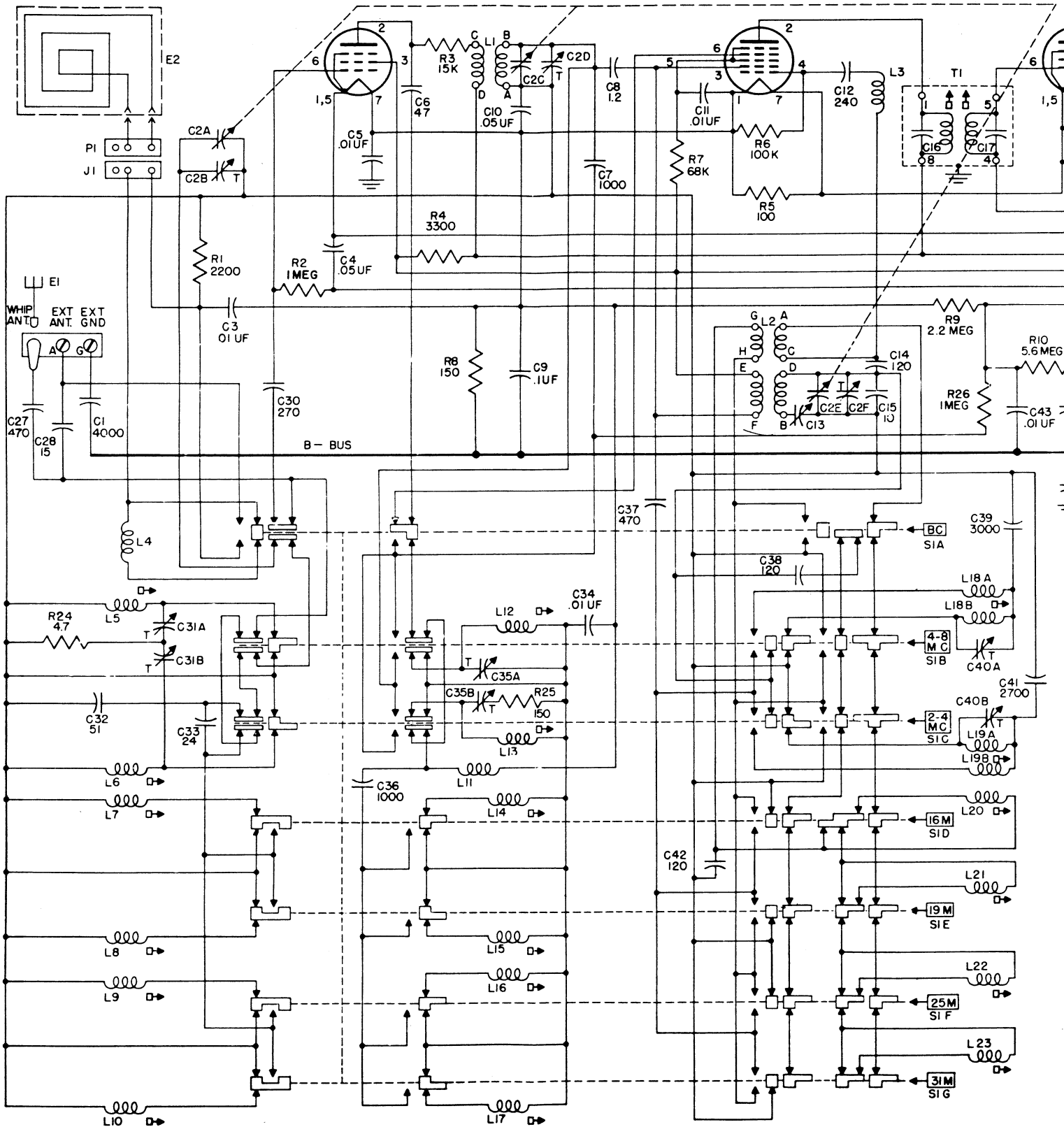

Figure 40. Radio Receiver 1

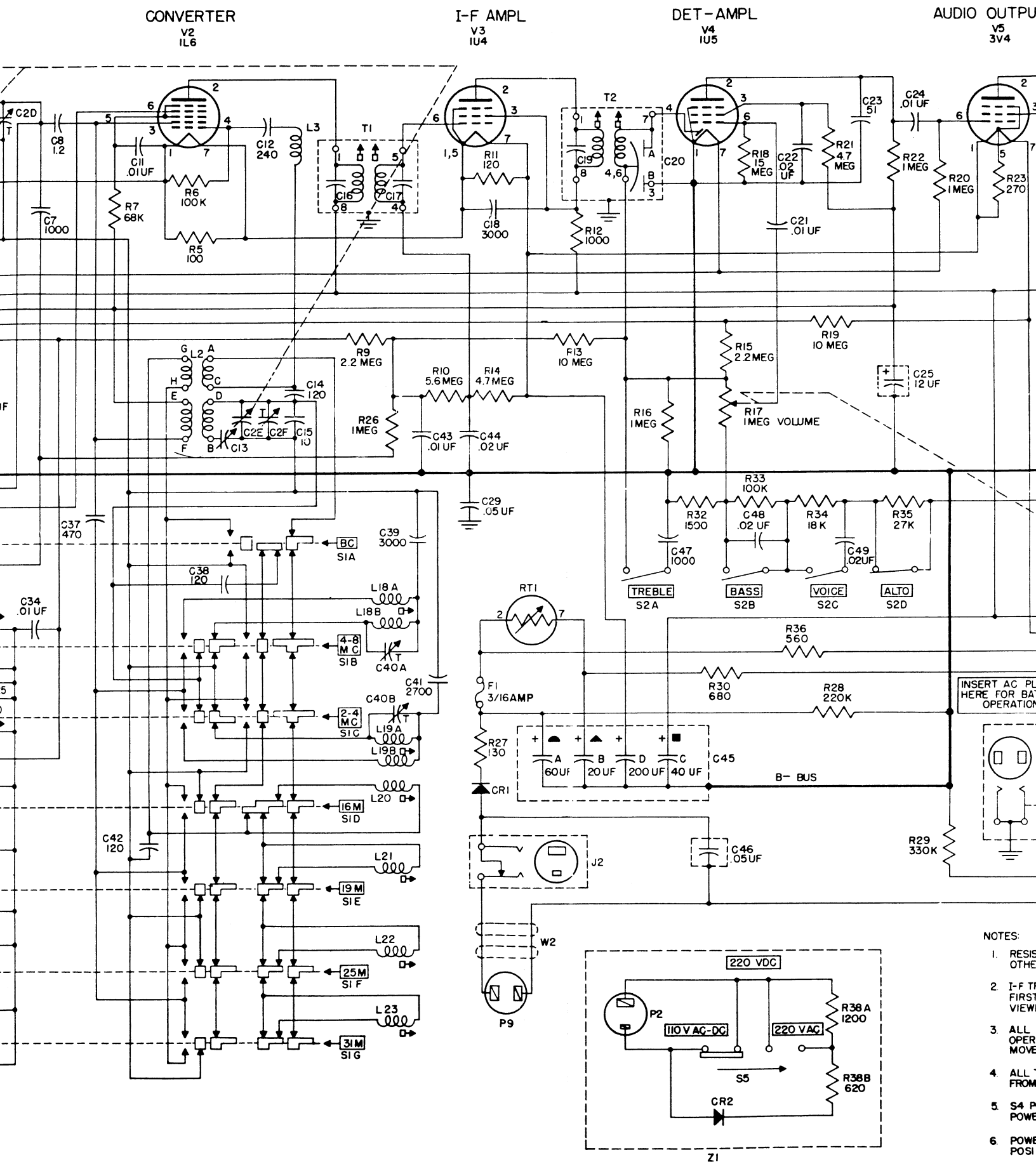
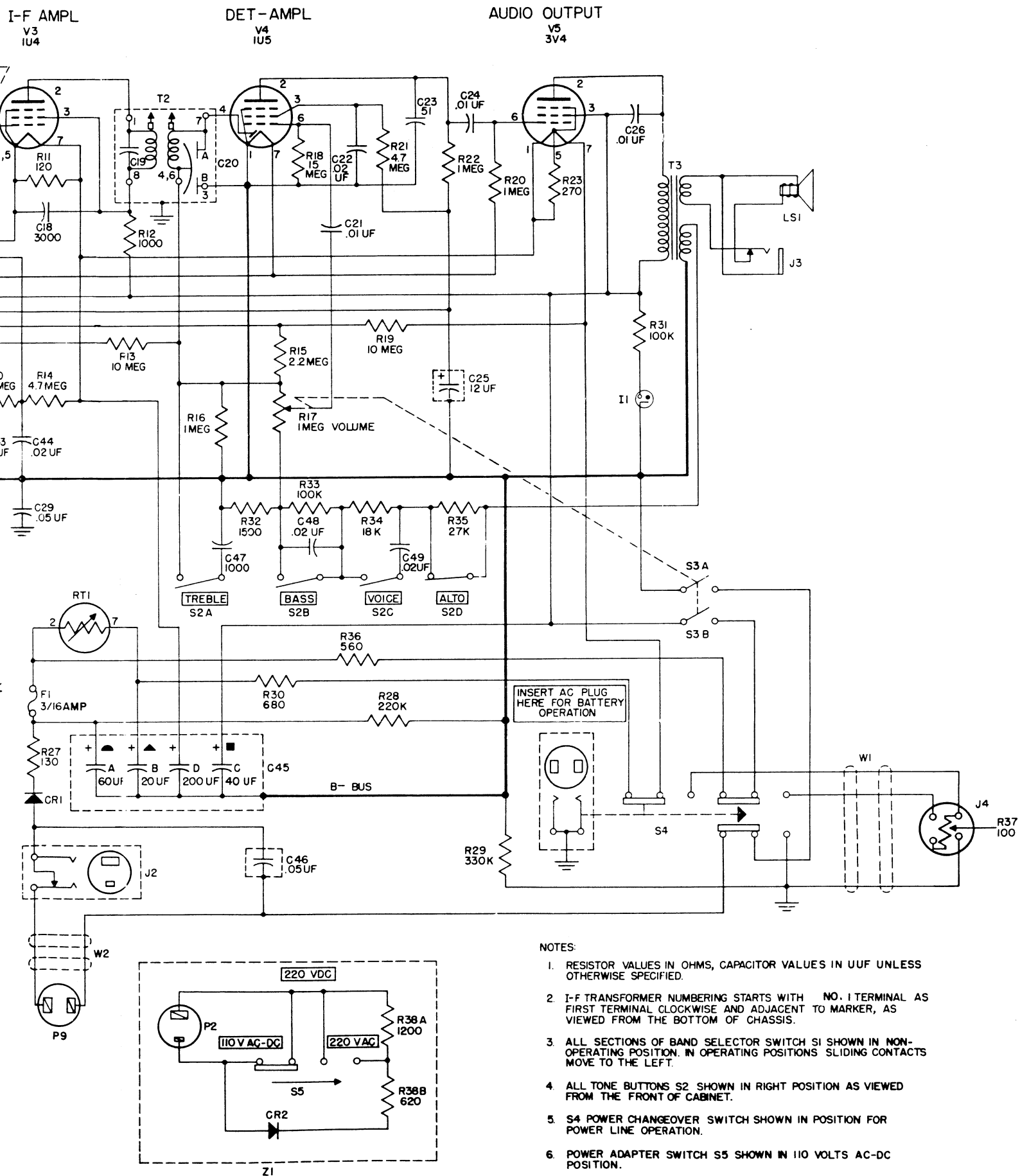

Figure 40. Radio Receiver R-520/URR, schematic diagram.

NOTES:

1. RESISTORS OTHER THAN THOSE SHOWN IN THIS SCHEMATIC ARE TO BE OBTAINED FROM THE MANUFACTURER'S CATALOG.
2. I-F TRANSFORMER FIRST VIEW.
3. ALL COMPONENTS TO BE OPERATED AT THE RATED VOLTAGE.
4. ALL CONNECTIONS TO BE MADE FROM THE POINTS SHOWN.
5. S4 POWER SWITCH.
6. POWER POSITIVE.



**NOTES:**

1. RESISTOR VALUES IN OHMS, CAPACITOR VALUES IN UUF UNLESS OTHERWISE SPECIFIED.
2. I-F TRANSFORMER NUMBERING STARTS WITH NO. 1 TERMINAL AS FIRST TERMINAL CLOCKWISE AND ADJACENT TO MARKER, AS VIEWED FROM THE BOTTOM OF CHASSIS.
3. ALL SECTIONS OF BAND SELECTOR SWITCH S1 SHOWN IN NON-OPERATING POSITION. IN OPERATING POSITIONS SLIDING CONTACTS MOVE TO THE LEFT.
4. ALL TONE BUTTONS S2 SHOWN IN RIGHT POSITION AS VIEWED FROM THE FRONT OF CABINET.
5. S4 POWER CHANGEOVER SWITCH SHOWN IN POSITION FOR POWER LINE OPERATION.
6. POWER ADAPTER SWITCH S5 SHOWN IN 110 VOLTS AC-DC POSITION.

# INDEX

---

	<i>Paragraph</i>	<i>Page</i>
<b>A</b>		
Accessories and running spares.....	7	5
Adapter, power supply.....	12,56	11,55
Additional equipment .....	8	6
Alinement chart.....	93	96
Alinement procedures:		
Broadcast band alinement .....	84	87
I-f .....	83	87
4- to 8-mc band.....	85	89
19 M band.....	89	93
16 M band.....	90	93
31 M band.....	87	92
25 M band.....	88	93
2- to 4-mc band.....	86	91
Preparation for alinement.....	82	86
Test equipment required for alinement.....	80	84
Antenna:		
External .....	4,18	2,19
Loop .....	4,18	2,19
Whip .....	4,19	2,21
Antenna stage (broadcast).....	44	42
Antenna stage test.....	74	79
Audio frequency signal substitution tests.....	71	77
Audio Output .....	51	50
Audio response .....	100	103
Avc and power output.....	101	104
Avc system .....	53	51
<b>B</b>		
Bands of operation.....	4	2
Battery power source.....	57	56



	<i>Paragraph</i>	<i>Page</i>
Bias system .....	54	53
Block diagram .....	42	40
Broadcast band alinement procedure.....	84	87
<b>C</b>		
Cabinet finish .....	37	33
Calibration, signal generator.....	81	85
Chassis installation .....	91	95
Chassis removal .....	64	65
Connections:		
Battery operation .....	13	14
Power line operation.....	12	11
Continuous coverage bands (2- to 4-mc and 4- to 8-mc) .....	47	43
Controls and their use.....	16	17
Controls, general .....	15	17
Converter stage (broadcast).....	46	43
<b>D</b>		
D-c resistance of coils and transformers.....	69	73
Demolition of materiel to prevent enemy use:		
General .....	104	106
Methods of destruction.....	105	106
Description of Radio Receiver R-520/URR.....	6	5
Detector-amplifier .....	50	49
Disassembly .....	64	65
Dry batteries .....	13	14
<b>E</b>		
Equipment performance check list.....	41	36
External power line source.....	56	55
<b>F</b>		
Filament circuit .....	58	57
Final testing:		
Audio response .....	100	103
Avc and power output.....	101	104
Image frequency check.....	99	102
Operation of controls.....	96	101
Selectivity .....	98	102
Sensitivity .....	97	102
Test equipment required for final testing.....	95	101
Forms and records.....	2	1
Fuse .....	12	11

	<i>Paragraph</i>	<i>Page</i>
<b>G</b>		
Gain, stage chart.....	76	80
General signal substitution notes.....	70	73
General trouble-shooting precautions.....	63	64
<b>H</b>		
Headset .....	22	22
H-f oscillator test.....	75	79
<b>I</b>		
I-f alinement procedure.....	83	87
I-f amplifier .....	49	49
I-f signal substitution tests.....	72	78
Image frequency check.....	99	102
Installation of receiver.....	11	10
<b>L</b>		
Localization of trouble.....	68	69
Logging scale .....	20	22
Lubrication .....	27	25
<b>M</b>		
Maintenance, preventive .....	33,34	30,31
<b>N</b>		
Neon Lamp .....	7	5
<b>O</b>		
Operation under unusual conditions:		
Arctic climates operation.....	25	24
Desert climates operation.....	27	25
General .....	24	23
Tropical climates operation.....	26	24
Operational test .....	67	67
<b>P</b>		
Packaging data and components.....	5	4
Plate and screen voltage distribution.....	59	59
Power control circuit.....	55	55
Power output .....	101	104
Power supply adapter.....	56	55
Preparation for alinement.....	82	86
Preventive maintenance:		
Definition .....	30	27
General preventive maintenance techniques....	31	27
Performing exterior preventive maintenance..	33	30
Performing interior preventive maintenance...	34	31
Use of preventive maintenance forms.....	32	30

**R**

R-f signal substitution tests.....	73	79
R-f stage (broadcast).....	45	42
Receiver, Radio R-520/URR, description.....	6	5
Records .....	2	1
Rectifier .....	56	55
Repacking for shipment or limited storage.....	103	105
Repairs:		
Front cover hinge repair.....	78	82
Refinishing .....	79	84
Replacement of parts.....	77	81

**S**

Scope .....	1	1
Selectivity (final testing).....	98	102
Sensitivity (final testing).....	97	102
Service upon receipt of equipment:		
Connections for battery operation.....	13	14
Connections for power line operation.....	12	11
Installation of receiver.....	11	10
Scope of instruction book.....	1	1
Sectionalization of trouble.....	68	69
Service upon receipt of used or reconditioned equipment .....	14	16
Shipment and limited storage:		
General .....	102	105
Repacking for shipment or limited storage....	103	105
Short-wave bands alinement procedure.....	85-90	89,93
Short-wave reception .....	19	21
Signal generator, calibration.....	81	85
Signal substitution notes (general).....	19	21
Siting .....	9	7
Spares, running .....	7	5
Special tools supplied with Radio Receiver		
R-520/URR .....	29	26
Spread bands .....	48	45
Stage gain and sensitivity chart.....	76	80
Standard broadcast reception.....	18	19
Starting procedure .....	17	17
Stopping procedure .....	23	23

**T**

Technical characteristics .....	4	2
Test equipment required for alinement.....	81	85

	<i>Paragraph</i>	<i>Page</i>
Test equipment required for final testing.....	95	101
Test equipment required for trouble shooting....	62	63
Thermal resistor .....	55,56,58	55,57
Tone control circuit.....	52	51
Tools and materials.....	28	26
Trouble-shooting charts .....	68	69
Trouble-shooting data .....	61	63
Trouble shooting, preliminary inspection.....	65	65
Trouble-shooting procedures .....	60	61
Tone control .....	21	22
Trouble shooting by using equipment performance checklist .....	41	36
Tuning circuits .....	43	41

**U**

Uncrating, unpacking, and checking new equipment .....	10	7
Unsatisfactory equipment report.....	2	1

**V**

Voltage and resistance measurements.....	66	67
------------------------------------------	----	----

**W**

Weatherproofing instructions .....	36	33
------------------------------------	----	----

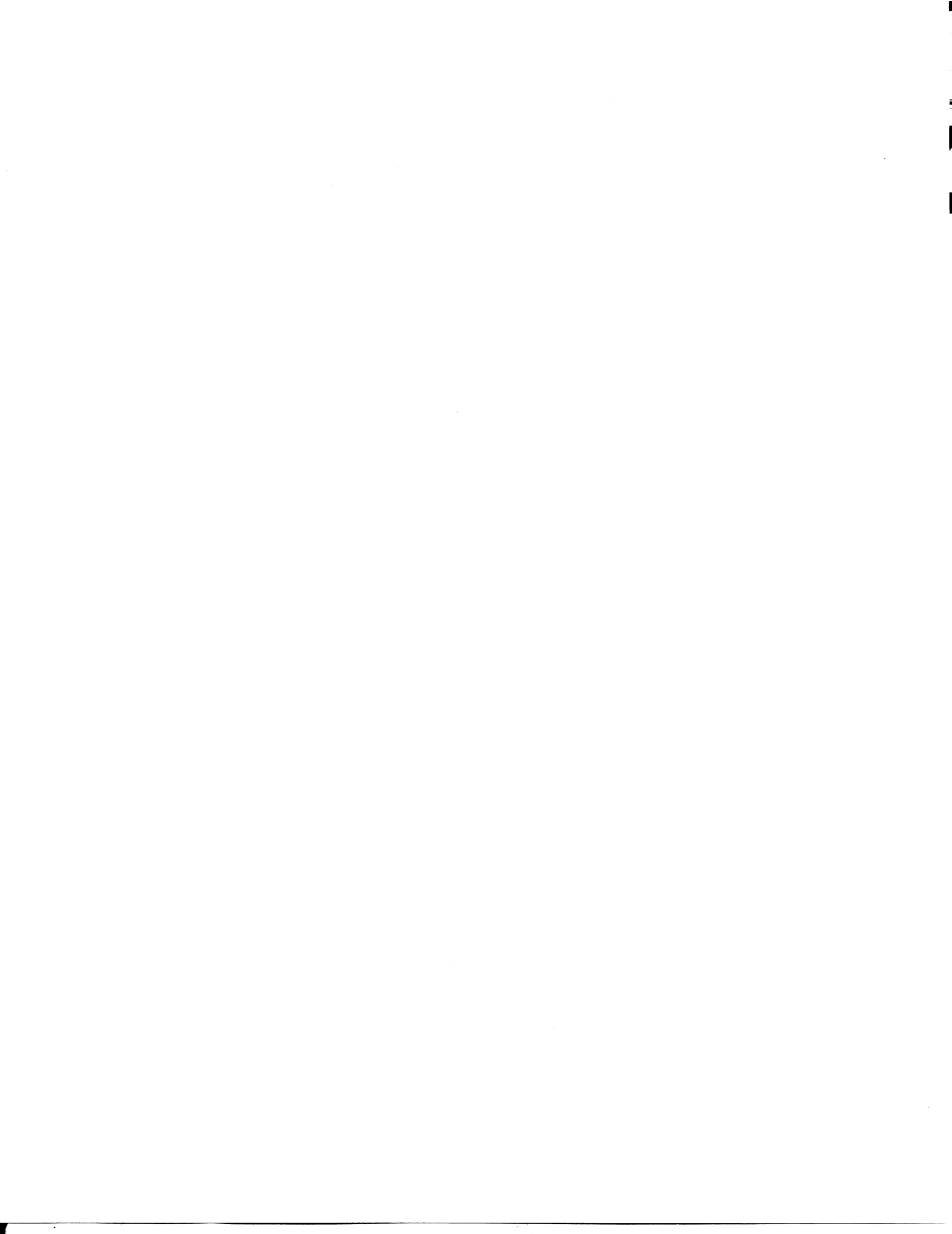

## TECHNICAL MANUAL

## RADIO RECEIVERS R-520/URR AND R-520A/URR

TM 11-877  
CHANGES NO. 1

DEPARTMENT OF THE ARMY  
WASHINGTON 25, D. C., 18 November 1955

TM 11-877, 12 January 1954, is changed as follows:

The title is changed to read: **RADIO RECEIVERS R-520/URR AND R-520A/URR.**

The following information changes TM 11-877 so that the manual also applies to the following equipment:

<i>Nomenclature</i>	<i>Order No.</i>	<i>Serial No.</i>
Radio Receiver R-520A/URR.....	31241-Phila-55	1 through 2973

Add "(and R-520A/URR)" after "R-520/URR" in the following places in the manual:

*Page 7, paragraph 1.* Third line.  
*Page 7, paragraph 3a.* First line.  
*Page 7, paragraph 3b.* First line.  
*Page 9, paragraph 5a.* First line.  
*Page 9, paragraph 5c.* First line.  
*Page 10, paragraph 6.* Paragraph heading.  
*Page 10, paragraph 6a.* First line.  
*Page 11, paragraph 8.* Second line.  
*Page 12, paragraph 9a.* Third line.  
*Page 13, paragraph 11.* First line.  
*Page 18, paragraph 13.* First line.  
*Page 26, paragraph 21a.* First line.  
*Page 27, paragraph 24.* First line.  
*Page 29, paragraph 28.* Paragraph heading.  
*Page 30, paragraph 32b.* Second line.  
*Page 34, paragraph 35a.* First line.  
*Page 41, paragraph 42.* First line.  
*Page 56, paragraph 55.* First line.  
*Page 60, paragraph 59a.* First line.  
*Page 70, paragraph 68.* Paragraph heading.  
*Page 80, paragraph 74.* Second line.  
*Page 82, paragraph 77.* First line.  
*Page 88, paragraph 85h.* Fourth line.  
*Page 98, paragraph 94a.* Second line.  
*Page 100, paragraph 99a.* Fourth line.

Change "(fig. 1)" to read "(fig. 1 and 1.1)" in the following places in the manual:

*Page 7, paragraph 3a.* First line.  
*Page 10, paragraph 6a.* First line.  
*Page 30, paragraph 33a.* Third line.

Change “(fig. 2)” to read “(fig. 2 and 2.1)” in the following places in the manual:

*Page 9, paragraph 5.* Heading.

*Page 13, paragraph 10b.* Heading.

Change “(fig. 3)” to read “(fig. 3 and 3.1)” in the following places in the manual:

*Page 13, paragraph 11.* Last line.

*Page 13, paragraph 12.* Second line.

*Page 30, paragraph 33a.* Third line.

Change “(fig. 4)” to read “(fig. 4 and 4.1)” in the following places in the manual:

*Page 13, paragraph 12.* Fifth line.

*Page 18, paragraph 13a.* Last line.

*Page 30, paragraph 33a.* Third line.

*Page 30, paragraph 33c.* Second line.

*Page 30, paragraph 33d.* Second line.

*Page 31, paragraph 33g.* Second line.

Change “(fig. 8)” to read “(fig. 8 and 8.1)” in the following places in the manual:

*Page 10, paragraph 6a.* Fourth line.

*Page 21, paragraph 16.* Heading.

*Page 23, paragraph 17b.* Second line.

*Page 23, paragraph 18.* Fourth line.

*Page 23, paragraph 18a(2).* First line.

*Page 26, paragraph 20.* Heading.

*Page 26, paragraph 21.* Heading.

*Page 31, paragraph 33e.* Third line.

*Page 31, paragraph 33i.* Fourth line.

Change “(fig. 9)” to read “(fig. 9, 9.1 and 9.2)” in the following places in the manual:

*Page 23, paragraph 18b(1).* Second line.

*Page 30, paragraph 33c.* Second line.

*Page 31, paragraph 33h.* Second line.

Change “(fig. 14)” to read “(fig. 14 and 14.1)” in the following places in the manual:

*Page 31, paragraph 34f.* Second line.

*Page 34, paragraph 35.* Heading.

Change “(fig. 16)” to read “(fig. 16 and 16.1)” in the following places in the manual:

*Page 42, paragraph 43a.* Third and sixth lines.

*Page 44, paragraph 44.* Heading.

*Page 44, paragraph 45.* Heading.

*Page 44, paragraph 46.* Heading.

Change “(fig. 17)” to read “(fig. 17 and 17.1)” in the following places in the manual:

*Page 42, paragraph 43b.* Fifth line.

*Page 45, paragraph 47.* Heading.

Change “(fig. 18)” to read “(fig. 18 and 18.1)” in the following places in the manual:

*Page 42, paragraph 43c.* Third line from bottom of page.

*Page 49, paragraph 48.* Heading.

Change “(fig. 22)” to read “(fig. 22 and 22.1)” in the following places in the manual:

*Page 55, paragraph 53.* Heading.

*Page 55, paragraph 53a.* Second line.

*Page 55, paragraph 54.* Heading.

*Page 56, paragraph 54f.* Second line from bottom of paragraph.

*Page 65, paragraph 61.* First column of the chart.

*Page 70, paragraph 68a(2).* Fourth line.

Change “(fig. 26)” to read “(fig. 26 and 26.1)” in the following places in the manual:

*Page 65, paragraph 61.* First column of the chart.

*Page 67, paragraph 64.* Heading.

*Page 81, paragraph 76a(3).* Third line.

Change “(fig. 28)” to read “(fig. 28 and 28.1)” in the following places in the manual:

*Page 30, paragraph 33d.* Last line.

*Page 31, paragraph 33i.* Last line.

*Page 31, paragraph 34c.* Last line.

*Page 31, paragraph 34g.* Last line.

*Page 31, paragraph 34h.* Last line.

*Page 65, paragraph 61.* First column of the chart.

*Page 87, paragraph 83.* Heading.

*Page 88, paragraph 84f.* First line.

*Page 88, paragraph 84g.* First line.

*Page 94, paragraph 92a(2).* Second line.

Change “(fig. 29)” to read “(fig. 29 and 29.1)” in the following places in the manual:

*Page 31, paragraph 34b.* Last line.

*Page 31, paragraph 34d.* Last line.

*Page 31, paragraph 34g.* Last line.

*Page 31, paragraph 34h.* Last line.

*Page 65, paragraph 61.* First column of the chart.

*Page 82, paragraph 77.* Second line.

Change “(fig. 30)” to read “(fig. 30 and 30.1)” in the following places in the manual:

*Page 31, paragraph 33i.* Last line.

*Page 31, paragraph 34b.* Last line.



*Page 88, paragraph 84i.* Second line.

*Page 94, paragraph 92a(3).* Second line.

Change “(fig. 32)” to read “(fig. 32 and 32.1)” in the following place in the manual:

*Page 65, paragraph 61.* First column of the chart.

Change “(fig. 40)” to read “(fig. 40 and 40.1)” in the following places in the manual:

*Page 41, paragraph 42.* Third line.

*Page 70, paragraph 68a(2).* Second line.

Add “(does not apply to model R-520A/URR)” in the following places in the manual:

*Page 9, paragraph 4.* End of the fourth line.

*Page 21, paragraph 13e.* End of subparagraph.

*Page 73, paragraph 68b(2).* Item 17. *Symptom* column.

*Page 83, paragraph 78.* Paragraph heading.

*Page 103, paragraph 103f.* End of subparagraph.

*Page 103, paragraph 103g.* End of subparagraph.

Add the following to the sentences listed below: “(This does not apply to Radio Receiver R-520A/URR.)”

*Page 18, paragraph 13.* Second sentence.

*Page 21, paragraph 13.* Note.

*Page 23, paragraph 17c.* Last sentence.

*Page 25, paragraph 19.* Heading.

*Page 45, paragraph 46.* Third sentence from the top of the page.

*Page 45, paragraph 46b.* Second sentence.

*Page 47, paragraph 47c.* Ninth line from the bottom of the page.

The sentence beginning with “A portion of”.

*Page 51, paragraph 48c(2).* Tenth line from the bottom of the paragraph. The sentence beginning “A portion of”.

Add “A pilot light is not used in Radio Receiver R-520A/URR.” in the following places in the manual:

*Page 13, paragraph 11.* End of first sentence.

*Page 23, paragraph 17b.* End of first sentence.

*Page 27, paragraph 23.* End of first sentence.

*Page 31, paragraph 33i.* End of subparagraph *i*.

*Page 31, paragraph 33j.* End of subparagraph *j*.

*Page 31, paragraph 34j.* End of third sentence.

*Page 37, paragraph 41a.* Checklist. Item 6. *Normal indications* column.

*Page 39, paragraph 41a.* Checklist. Item 14. *Normal indications* column.

*Page 40, paragraph 41b.* Checklist. Item 6. *Normal indications* column.

*Page 71, paragraph 68b(l).* Troubleshooting chart. Item 3. *Symptom* column.

Add the following note to the figures listed below: 5. IN RADIO RECEIVER R-520A/URR ADD LINE CORD FUSES F2 AND F3 AT THE POWER LINE PLUG. FUSE F2 IS PLACED IN SERIES WITH THE LEAD GOING TO J2 AND FUSE F3 IS PLACED IN SERIES WITH THE LEAD GOING TO CAPACITOR C46.

*Page 61, figure 24.*

*Page 62, figure 25.*

Add "(In Radio Receiver R-520A/URR, the loop is fastened to the top of the cabinet.)" in the following places in the manual:

*Page 8, paragraph 4.* Antennas. Line one after the first sentence.

*Page 10, paragraph 6b.* After the second sentence.

Add "(In Radio Receiver R-520A/URR, no avc voltage is applied to the grid of converter stage V2.)" in the following places in the manual:

*Page 42, paragraph 42d.* After last sentence.

*Page 55, paragraph 53c.* After last sentence.

*Page 55, paragraph 53d.* After last sentence.

*Page 56, paragraph 54b.* After sentence ending with word "signals."

Add "(This wrench is not supplied with Radio Receiver R-520A/URR.)" in the following places in the manual:

*Page 29, paragraph 28.* After fifth line.

*Page 86, paragraph 80e.* After last sentence.

*Page 87, paragraph 83a.* After the first sentence.

*Page 3.* Add the following to the WARNING notice:

**Caution:** Set power supply adapter to correct position for type of power source before using receiver on power line operation.

*Page 6.* Insert figure 1.1 after figure 1.

*Page 9, paragraph 4.* Delete the heading of right-hand column.

*Page 9, paragraph 5.* Add the following after subparagraph *a*.

*a.1.* Radio Receiver R-520A/URR is shipped without batteries. The receiver is placed in a corrugated fiberboard carton and sealed with gummed tape, 3 inches wide.

*Page 10, paragraph 7.* Add the following after subparagraph *a*:

*a.1.* Included in the cabinet of Radio Receiver R-520A/URR are the spare fuses, loop antenna, suction cups, the battery cable assembly, two technical manuals, and two Changes No. 1.

*Page 10.* Add the following after subparagraph *b*:

*b.1.* In Radio Receiver R-520A/URR, the following spare fuses are provided in the boxes fastened to the inside of the cabinet back.

5 fuses,  $\frac{3}{16}$  ampere.

5 fuses,  $\frac{1}{4}$  ampere.

Item	Height (in.)	Width (in.)	Depth (in.)	Volume (cu ft)	Unit weight (lb)
Carton.....	13 $\frac{3}{4}$	19 $\frac{1}{4}$	10 $\frac{1}{4}$	1. 6	24



Figure 1.1. Radio Receiver R-520A/URR.

Page 11. Add the following after paragraph 8:

### 8.1. Differences in Models

Radio Receiver R-520A/URR bearing Order No. 31241-Phila-55 differs from Radio Receiver R-520/URR in the following respects:

*a. Appearance.*

- (1) The cabinet is olive drab No. 7.
- (2) The knobs, escutcheon, loop, and handle are black.
- (3) The dial scale is a slide rule type.
- (4) A re-designed loop antenna is mounted in the top of the cabinet.

*b. Major Circuit Differences.*

- (1) The tuning capacitor is grounded to the chassis.
- (2) The converter has no avc.
- (3) There is an antenna matching coil on the BC band.

*c. Parts Added.*

- (1) Line cord fuses F2 and F3.
- (2) Antenna coupling coil L24.
- (3) Resistor R39.

*d. Parts not Included.*

- (1) Pilot light and bracket.
- (2) Power line cord adapters.
- (3) Red harness battery cable.
- (4) Black harness battery cable.
- (5) Alinement tool No. 014.
- (6) Dust cover guard A 3.
- (7) Rf choke coil L11.
- (8) Resistors R1, R3, R24, and R31.
- (9) Capacitors C3, C8, C10, C36, and C43.
- (10) Cabinet back door release latch A 7.

*e. Interchangeable Major Parts.*

- (1) Tubes.
- (2) Adapter Z1.
- (3) Yellow battery cable W5.
- (4) All coils of band switch assembly, except L4, L6, and L13.
- (5) If. transformers T1 and T2.
- (6) Filter capacitors C45A, C45B, C45C, and C45D.
- (7) Whip antenna E1.
- (8) Tone control switch assembly.

Page 13, paragraph 12. Add the following after the first sentence:  
(In Radio Receiver R-520A/URR, latch A 7 is omitted.)

Page 13, paragraph 12. Fifth line. Change "(fig. 4)" to read: (fig. 5).

Page 14. Insert figure 2.1 after figure 2.

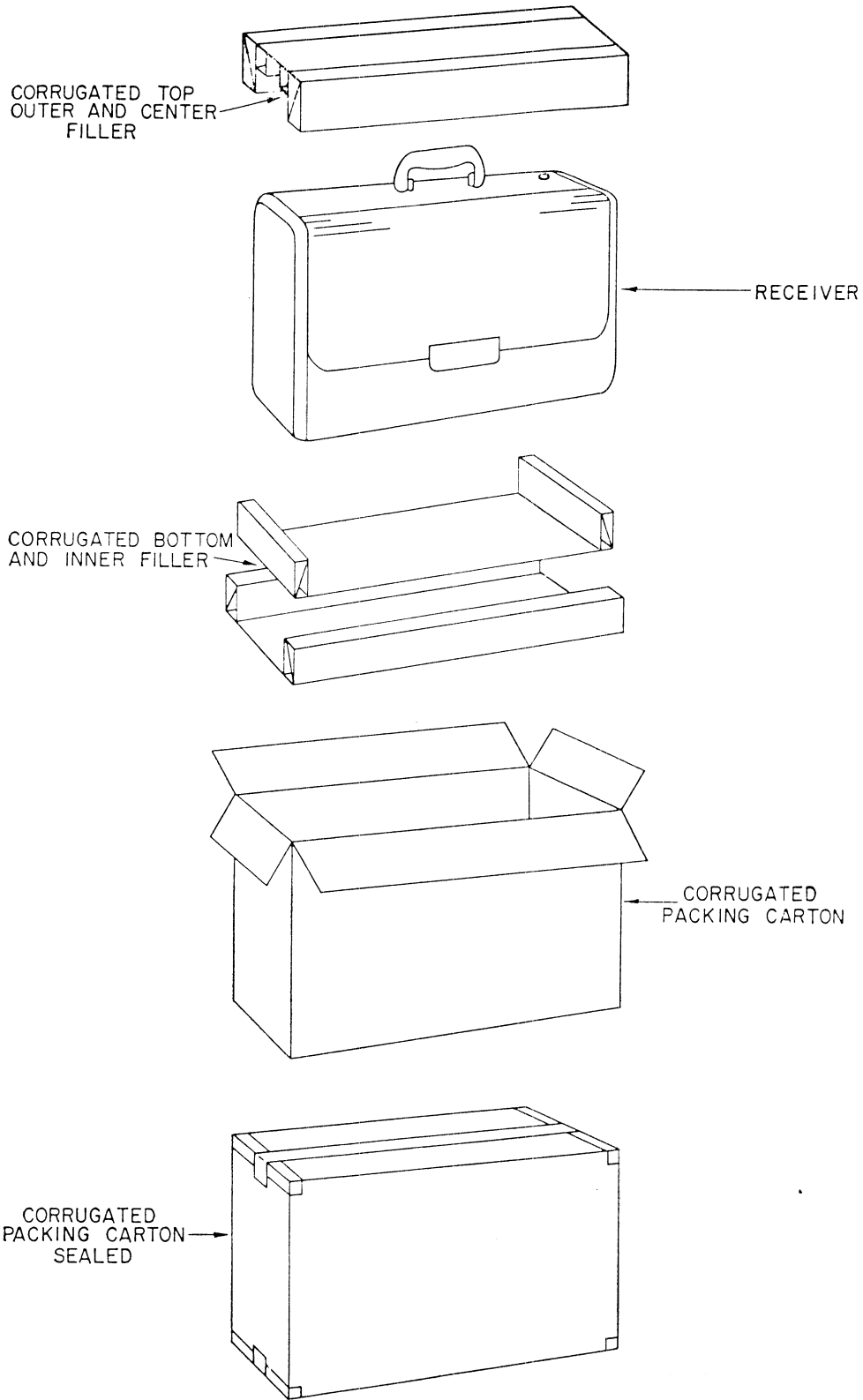

TM877-CI-2

Figure 2.1. Packing and packaging of Radio Receiver R-520A/URR.

Page 15, paragraph 12. Add the following after the last sentence of the introductory statement:

**Warning:** Be sure that the power supply adapter switch, located on power supply adapter Z1 (fig. 5), is in the correct position to conform to the type of power from which the set is to be operated.

Page 15. Insert figure 3.1 after figure 3.

Page 15, paragraph 12. Add the following after subparagraph *b*:

*b.1.* In Radio Receiver R-520A/URR, remove and check fuses F2 and F3 located inside of the line cord plug (fig. 30.1).

**Warning:** Do not use fuses rated higher than  $\frac{1}{4}$  ampere; the receiver may become seriously damaged.

Page 16. Insert figure 4.1 after figure 4.

Page 18, paragraph 12. Add the following sentence at end of subparagraph *c*:

(In Radio Receiver R-520A/URR no power line cord adapters are included.)

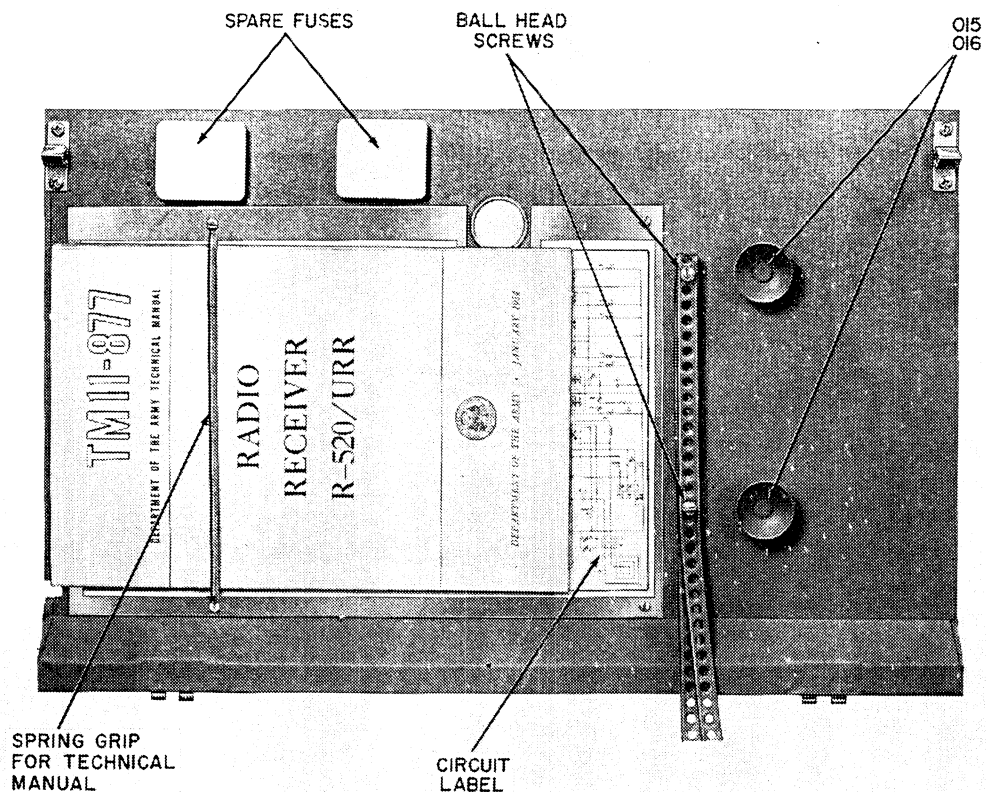

TM877-CI-3

Figure 3.1. Spare parts and accessories, Radio Receiver R-520A/URR.

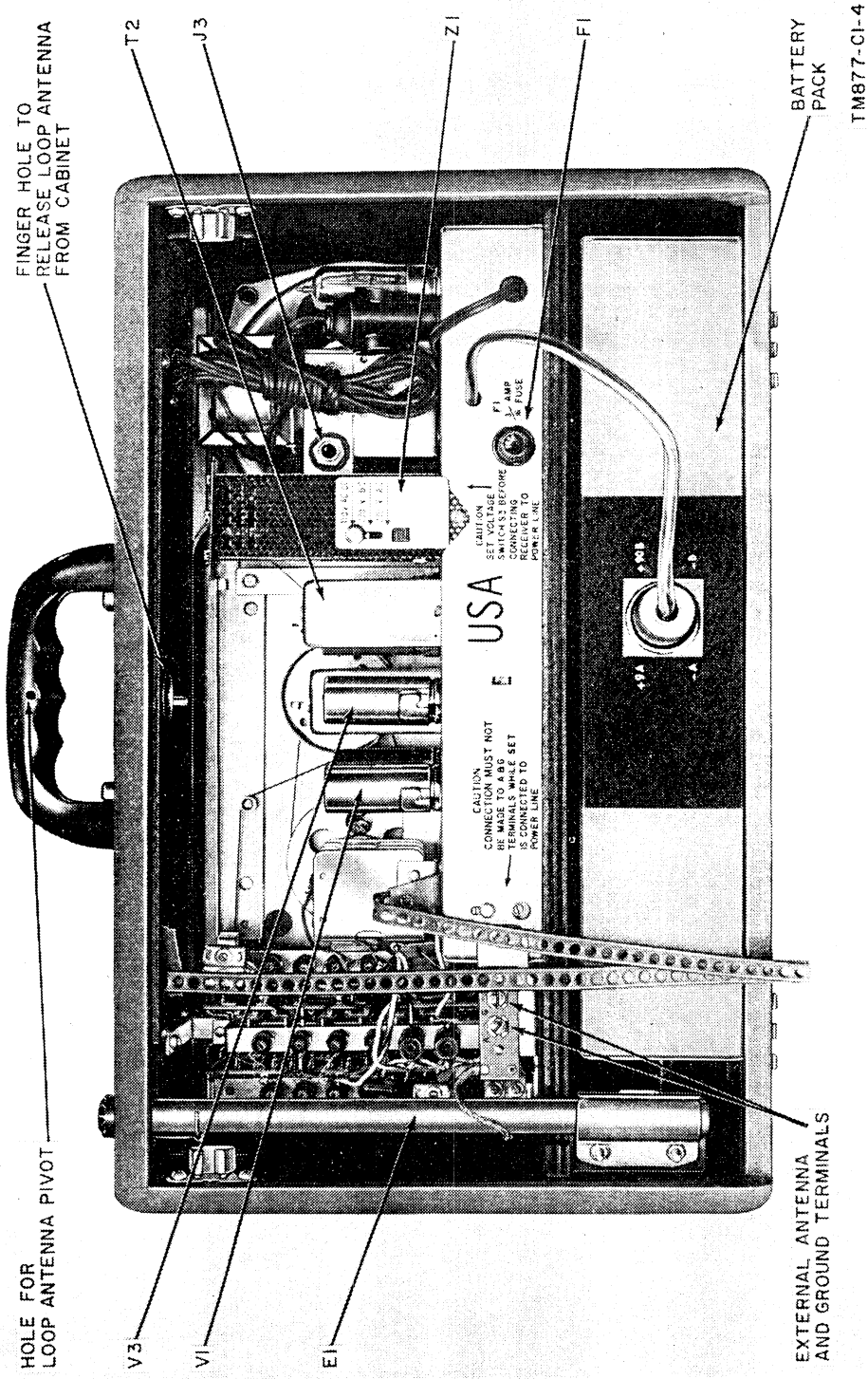

Figure 4.1. Radio Receiver R-520A URR, rear view, back cover open, showing typical battery complement.

*Page 19, paragraph 13.* Add the following note at end of chart in subparagraph *b*:

*Note.* The information in subparagraph *b* does not apply to model R-520A/URR.

*Page 20, paragraph 13.* Add the following note at end of chart in subparagraph *c*:

*Note.* The information in subparagraph *c* does not apply to model R-520A/URR.

*Page 20, figure 7.* Add the following note to figure 7:

*Note.* IN RADIO RECEIVER R-520A/URR W6 IS NOT USED.

*Page 22.* Insert figure 8.1 after figure 8.

*Page 23, paragraph 18.* Add the following after the first sentence:  
(In Radio Receiver R-520A/URR, the broadcast band is located at the bottom of the dial (fig. 8.1).)

*Page 23, paragraph 18.* Add the following to subparagraph *a*(1):  
(In Radio Receiver R-520A/URR the band selector switch buttons are black.)

*Page 23, paragraph 18.* Add the following after subparagraph *a*(4):  
(5) In Radio Receiver R-520A/URR, the following procedure is recommended to improve reception on the broadcast band:  
(*a*) Free the loop antenna cable from the ball head screws which hold the cable to the cabinet back (fig. 3.1).  
(*b*) Remove the loop antenna by pressing upward through the fingerhole provided at the center under the edge of the cabinet top (fig. 4.1).  
(*c*) Tilt the cabinet handle forward as far as it will go. Place the pivot at the bottom of the loop antenna into the hole in the top of the handle (fig. 9.2). Rotate the loop antenna to the position of best reception and least interference.

*Page 24, paragraph 18.* Add the following after subparagraph *b*:  
*b.1.* For Radio Receiver R-520A/URR, use the following procedure:

- (1) Carefully remove the loop antenna cable from the two ball head screws on the cabinet back (fig. 3.1).
- (2) Press up through the fingerhole provided at the center under the edge of the cabinet top and remove loop antenna E2 (fig. 4.1).
- (3) Remove the suction cups from the inside of the cabinet back and place them onto loop antenna E2 (fig. 9.1).
- (4) Moisten the suction cups and apply the loop antenna to a corner of a window.



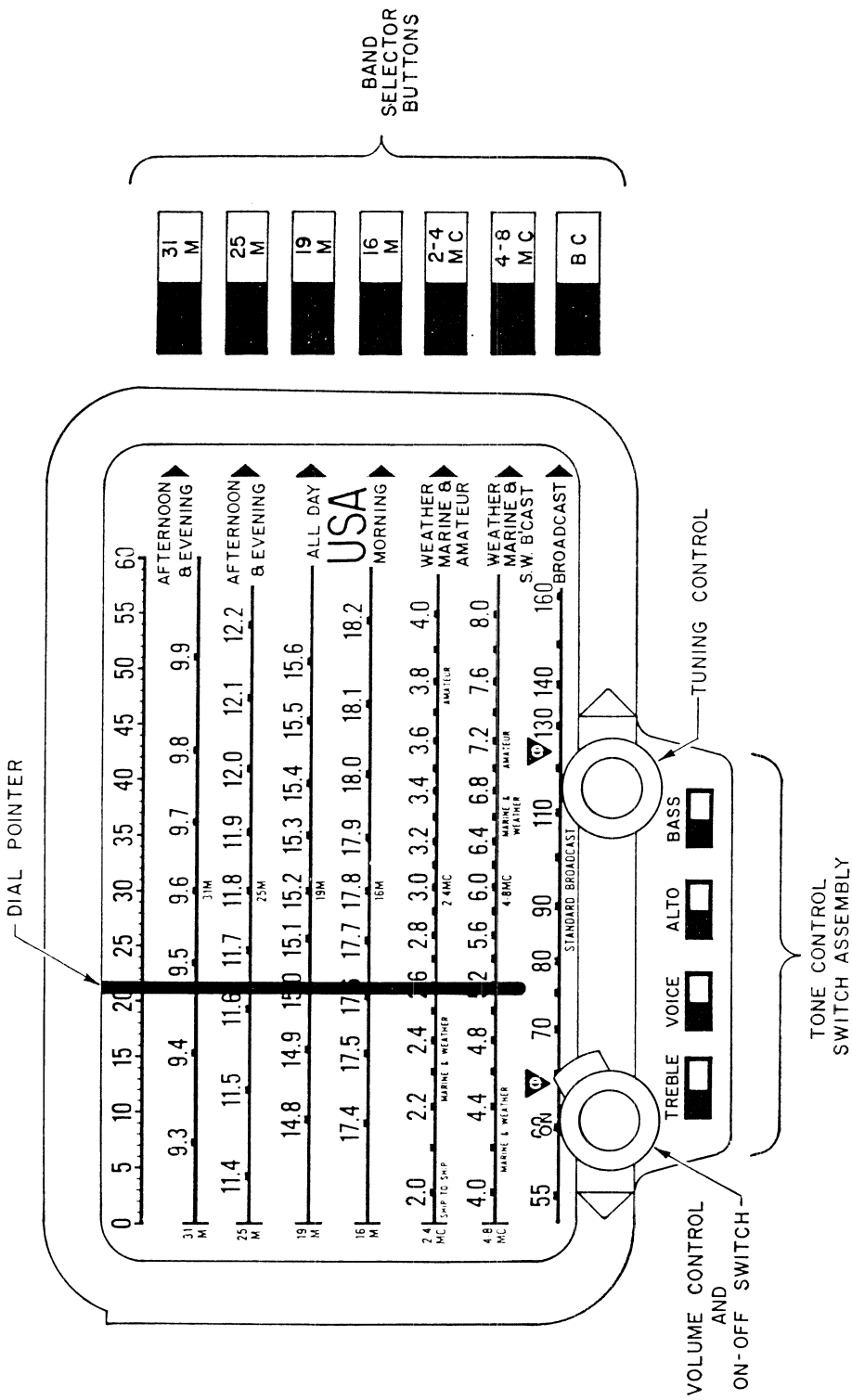

TM877-CI-5

Figure 8.1. Radio Receiver R-520A/URR, front panel.

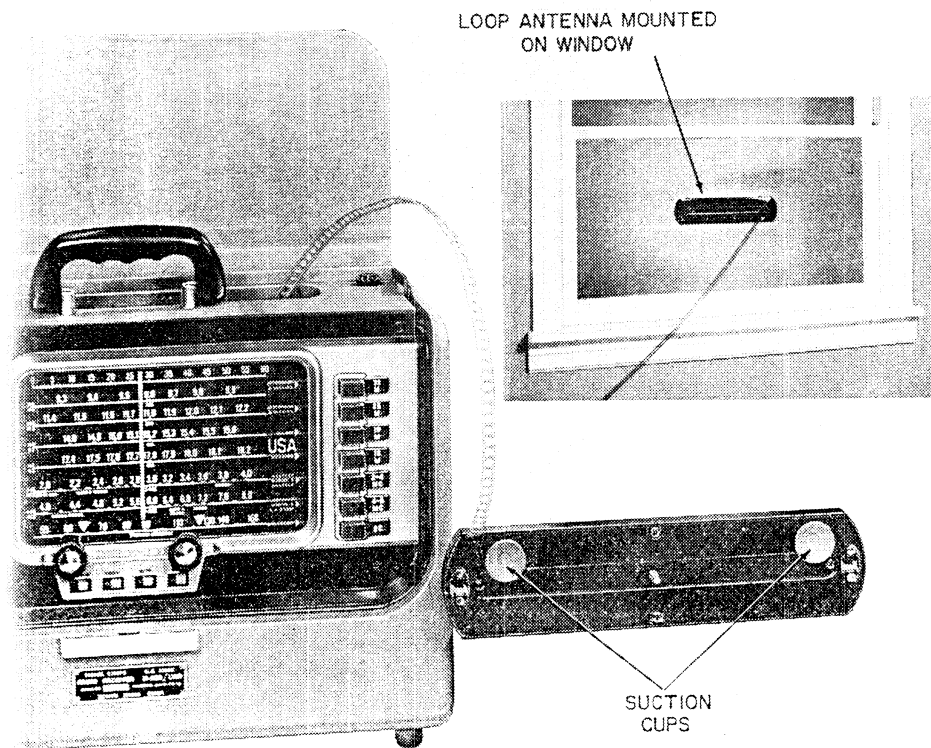

TM877-CI-6

Figure 9.1. Loop antenna for Radio Receiver R-520A/URR.

Page 24. Insert figures 9.1 and 9.2 after figure 9.

Page 25, figure 10. Add the following note to figure 10.

Note. IN RADIO RECEIVER R-520A/URR, COVER A 3 AND ALIGNMENT TOOL O 14 ARE NOT SUPPLIED.

Page 30, paragraph 33. Add the following after subparagraph *d*.

*d.1.* In Radio Receiver R-520A/URR, inspect the seating of accessible pluck-out items: tubes, fuses F1, F2, F3, and power supply adapter Z1 (figs. 4.1, 5, and 28.1).

Page 34. Insert figure 14.1 after figure 14.

Page 35, paragraph 38a. Change the third word of the second line to read: maintenance.

Pages 37 and 39. Add the following to the check list in subparagraph *a*:

Item No. 2. *Action or condition* column. "(In Radio Receiver R-520A/URR, set the loop antenna into a swivel position on the handle (fig. 9.2).)"

Item No. 6. *Normal Indications* column. "(In Radio Receiver R-520A/URR, a signal should be received.)"



TM877-CI-7

Figure 9.2. Location of loop antenna for orientation for Radio Receiver R-520A/URR.

Item No. 6. *Corrective measures* column. “(In Radio Receiver R-520A/URR, there are three fuses to be checked.)”

Item No. 14. *Normal indications* column. “(When Radio Receiver R-520A/URR is turned off the volume control knob covers the word ON above the dial window.)”

Page 40, paragraph 41. Add the following to the checklist in subparagraph b.

Item No. 2. *Action or condition* column. “(In Radio Receiver R-520A/URR set loop antenna into swivel position on handle (fig. 9.2).)”

Item No. 6. *Normal indications* column. “(In Radio Receiver R-520A/URR a signal should be received.)”

Page 41, paragraph 42. In subparagraph c, second line, change fixed-tubed to read: fixed-tuned.

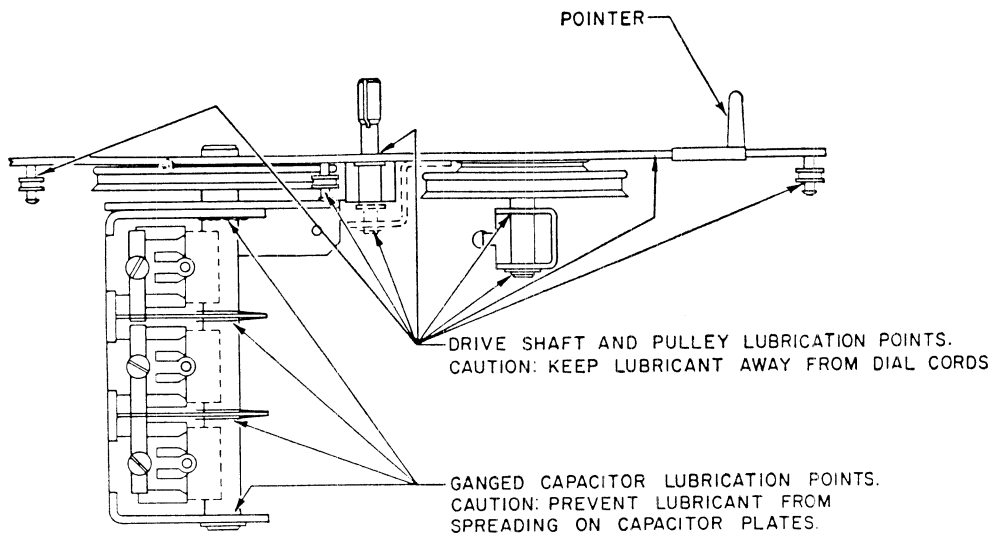

TM877-C1-8

Figure 14.1 Lubrication points for Radio Receiver R-520A/URR.

Page 43, figure 15. Add the following note to figure 15.

Note. IN RADIO RECEIVER R-520A/URR, NO AVC IS APPLIED TO THE CONVERTER.

Page 44, paragraph 44. Add the following after paragraph 44.

#### 44.1. Broadcast Antenna Stage, Radio Receiver R-520A/URR

In Radio Receiver R-520A/URR, antenna coil L24 and resistor R39 form a matching network on B. C. band operation when a long wire antenna is used. The long wire antenna is connected through the band selector switch to the high impedance primary of L24. The low impedance secondary of L24 is connected in series to loop antenna E2. Maximum signal energy from both the long wire antenna and the loop are coupled into the rf stage V1 with minimum de-tuning of the loop antenna. Resistor R39 is shunted across the high impedance primary of L24 to minimize resonance effects when the receiver is tuned on the continuous coverage short wave bands.

Page 44, paragraph 45. Add the following after the first sentence:

“(In Radio Receiver R-520A/URR, damping resistor R3 is not used.)”

Page 46. Insert figure 16.1 after figure 16.

Page 47, paragraph 47. In subparagraph *a*, add the following after the fifth sentence:

(In Radio Receiver R-520A/URR parasitic suppressor R24 is omitted.)

Page 47, paragraph 47. In subparagraph *b*, add the following after the third sentence:

(In Radio Receiver R-520A/URR capacitor C10 is omitted.)

*Page 48.* Insert figure 17.1 after figure 17.

*Page 49, paragraph 48.* Add the following note at the end of subparagraph *b*:

*Note.* In Radio Receiver R-520A/URR, rf choke coil L11 and capacitor C36 are omitted.

*Page 50.* Insert figure 18.1 after figure 18.

*Page 52, figure 19.* Add the following note to figure 19:

*Note.* IN RADIO RECEIVER R-520A/URR, THE VALUE OF CAPACITOR C18 IS CHANGED TO 3,300.

*Page 53, figure 20.* Add the following note to figure 20:

*Note.* IN RADIO RECEIVER R-520A/URR, THE VALUE OF CAPACITOR C26 IS CHANGED TO 6,800.

*Page 55, paragraph 53.* Add the following after subparagraph *a*:

*a. 1.* In Radio Receiver R-520A/URR, the ave system controls the gain of the rf and if. stages only. Figure 22.1 shows the ave network for the broadcast and continuous coverage bands.

*Page 55, paragraph 53.* Add the following at end of subparagraph *b*:

(In Radio Receiver R-520A/URR only two levels of ave voltage are developed.)

*Page 55, paragraph 53.* Add the following at end of subparagraph *d*:

(In Radio Receiver R-520A/URR capacitor C43 is omitted.)

*Page 56, paragraph 54.* Add the following after subparagraph *e*:

*e. 1.* In Radio Receiver R-520A/URR, the input control grid of V2 returns to its own filament through resistor R26. Rf choke coil L11 is omitted and no ave voltage is applied to V2 on any band. On spread band operation, either of the four converter grid coils L14, L15, L16, or L17 is shunted across resistor R26 through the band selector switch. The low dc resistance of the coils prevents the control grid of the L16 converter tube from accumulating any grid charge on the high short wave frequencies (fig. 18.1).

*Page 56, paragraph 55.* Add the following after the first sentence: In Radio Receiver R-520A/URR, there are two additional fuses, F2 and F3, installed in the line cord plug (fig. 30.1).

*Page 57.* Insert figure 22.1 after figure 22.

*Page 58, paragraph 56.* Add the following at end of subparagraph *a*: In Radio Receiver R-520A/URR, two ¼-ampere fuses are also contained in the line cord plug to protect the power supply circuit.

*Page 63, paragraph 59.* Add the following at end of subparagraph *a*: In Radio Receiver R-520A/URR, resistor R3 is omitted.

*Page 61, figure 24.* Add the following to the notes on figure 24:

5. IN RADIO RECEIVER R-520A/URR, A WIRE CONNECTION IS USED INSTEAD OF RESISTOR R3.

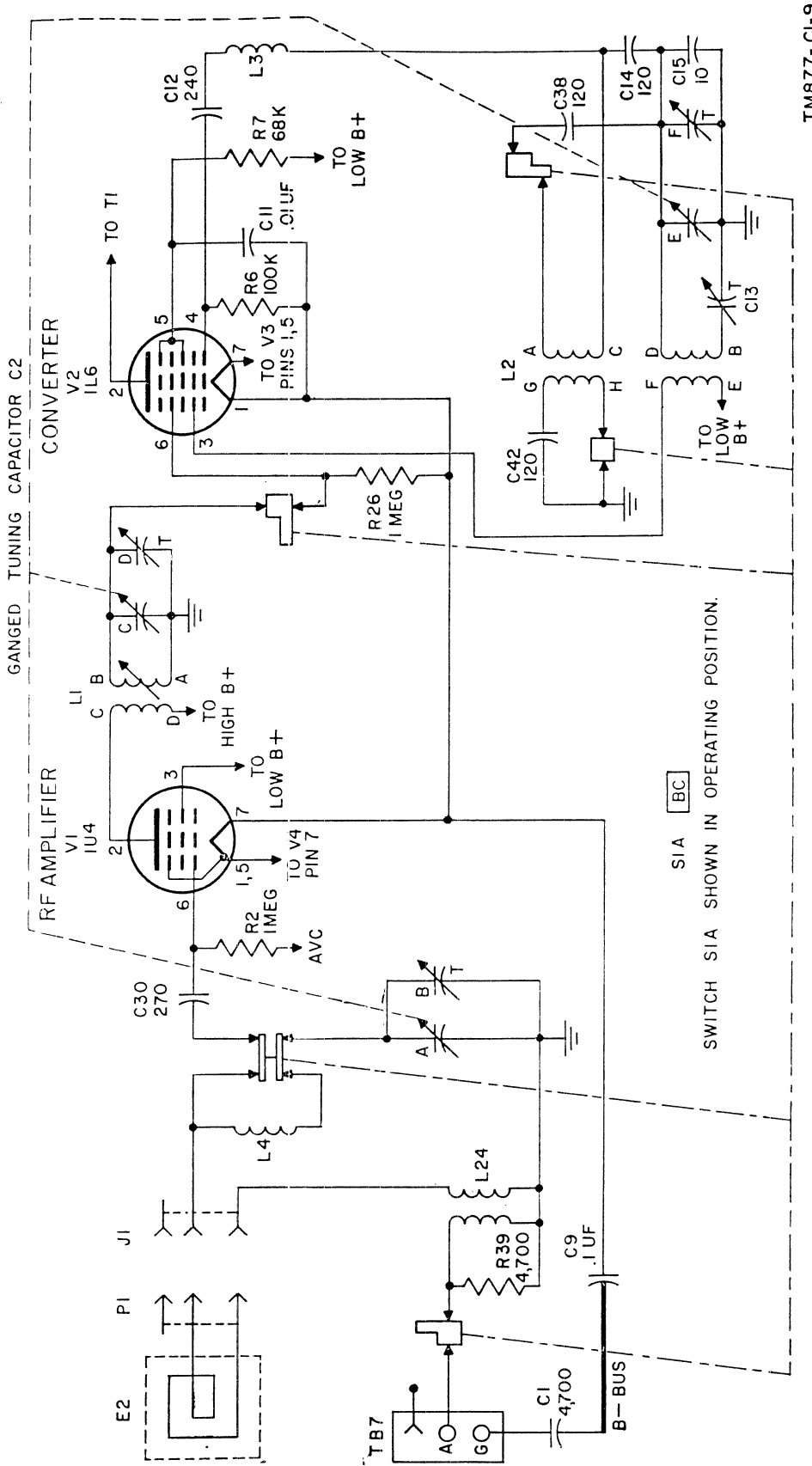

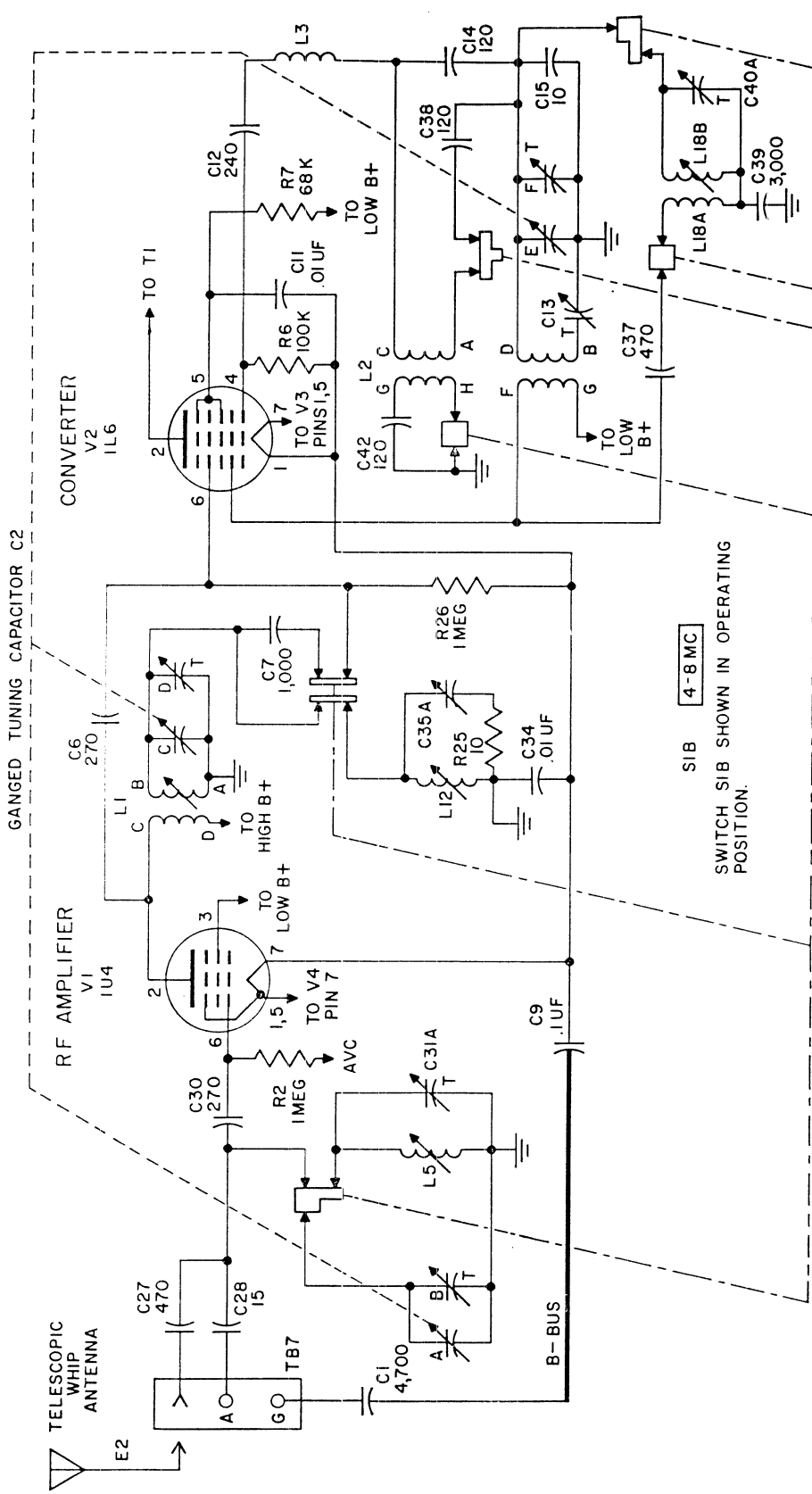

Figure 17.1. Typical continuous coverage band (4 to 8 mc), antenna, rf amplifier and converter circuits for Radio Receiver R-520A/URR.

TM877-CI-10

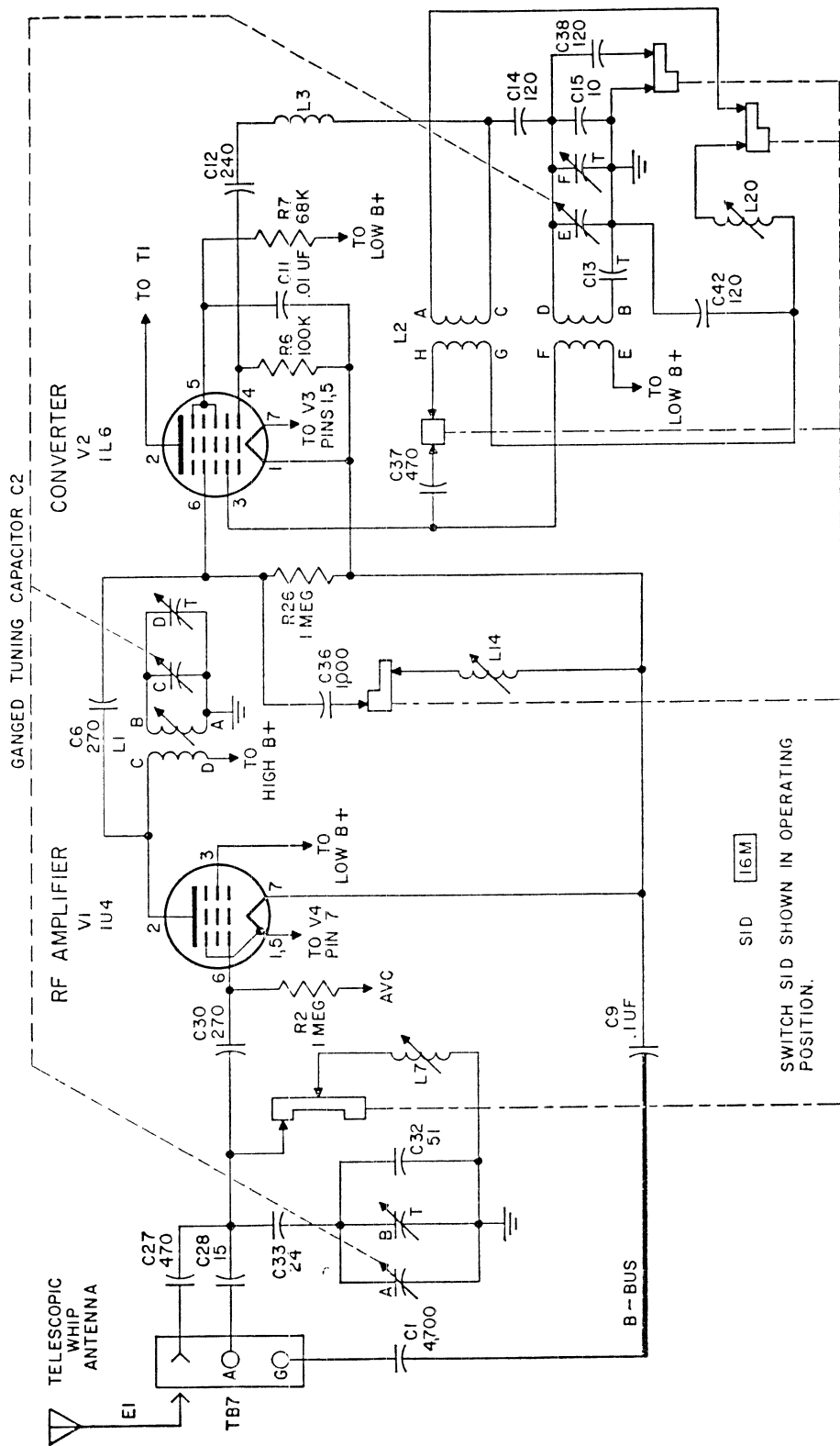

Figure 18.1. Typical spread band (16M) antenna, rf amplifier, and converter circuits for Radio Receiver R-520A/URR.



*Page 62, figure 25.* Disconnect capacitor C46 from J2 and reconnect it to the junction of CR1 and J2.

*Page 67, paragraph 64.* Make the following additions:

Add the following to subparagraph *d*: (In Radio Receiver R-520A/URR, no line cord adapters are supplied.)

*Page 67, paragraph 64.* Add the following to subparagraph *e*: (In Radio Receiver R-520A/URR, no protective cover A 3 is supplied.)

*Page 67, paragraph 64.* Add the following to subparagraph *g*: (In Radio Receiver R-520A/URR, only two chassis mounting screws and lockwashers are supplied.)

*Page 67.* Insert figure 26.1 after figure 26.

*Page 68, paragraph 65.* In subparagraph *d*, add the following after the first sentence: (In Radio Receiver R-520A/URR inspect the fuses.)

*Page 69, figure 27.* Make the following changes on figure 27: Change pin 6 of V2 to read: 2.8 V 2.3 MEG.

Delete note 4C.

Correct note 4B to read: ON-OFF VOLUME CONTROL SWITCH IN ON POSITION.

Add the following note:

7. IN RADIO RECEIVER R-520A/URR, THE READING AT PIN 5 OF V4 IS 0 VOLT, 0 RESISTANCE. THE READING OF PIN 6 OF V2 IS 2.8 V, 1 MEG.

*Page 71, paragraph 68b(1).* Item 4. *Probable trouble* column. Add the following: (In Radio Receiver R-520A/URR there are three fuses: F1, F2, and F3.)

*Page 75.* Insert figure 28.1 after figure 28.

*Page 76.* Insert figure 29.1 after figure 29.

*Page 77.* Insert figure 30.1 after figure 30.

*Page 83, paragraph 77.* Add the following after subparagraph *b*:

*b. 1.* Figure 32.1 shows the dial cord system used on Radio Receiver R-520A/URR. Three dial cords are used: one for the pointer, one for the dial tuning shaft, and one as the idler cord between the idler pulley and the drive pulley. The pointer cord can be replaced without removing the dial scale. It is necessary to remove the dial scale in order to replace either the tuning cord or the idler cord. When replacing the tuning cord, first string it around the tuning shaft. Before replacing the pointer cord, be certain that the tuning cord and idler cord are installed correctly. Replace the pointer cord by first

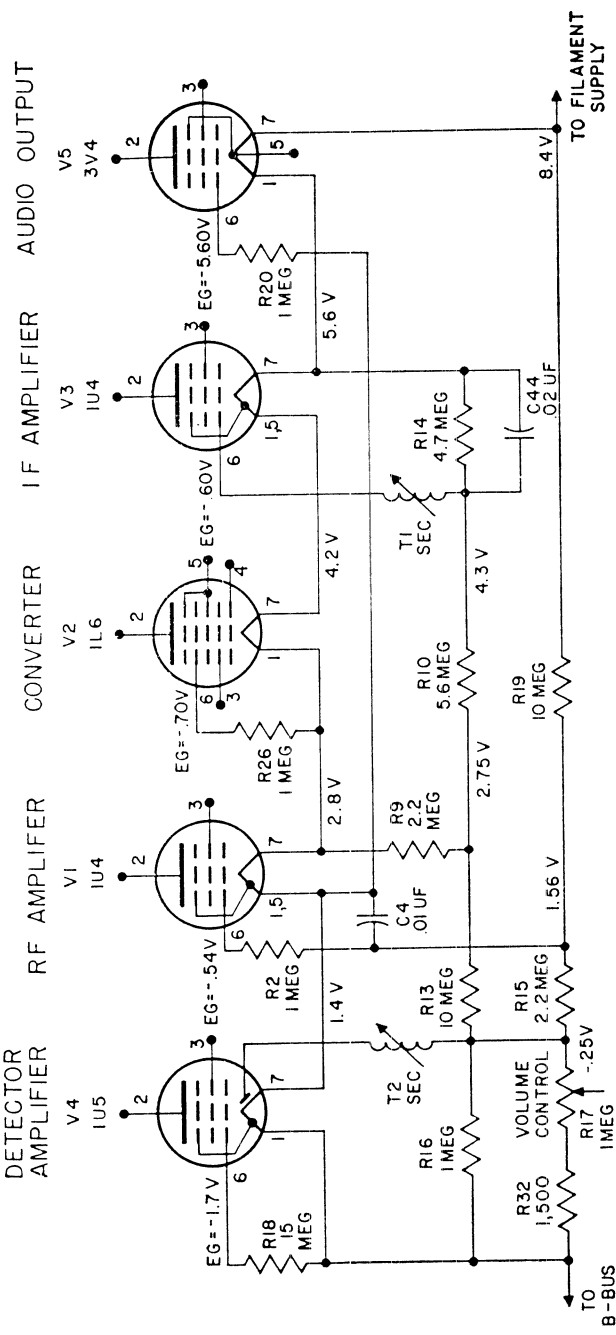

	VOLTAGES		
	FILAMENT CENTER	GRID RETURN	EG
DET-AMPL	V4 1U5	.7V	-1.7V
RF AMPL	V1 1U4	2.1V	-.54V
CONVERTER	V2 1L6	3.5V	-.70V
IF AMPL	V3 1U4	4.9V	-.60V
AUDIO OUTPUT	V5 3V4	7.0V	-5.60V

NOTES

1. ALL VOLTAGES ARE CALCULATED VALUES UNDER NO-SIGNAL CONDITION.
2. FILAMENT CENTER VOLTAGES AND GRID RETURN VOLTAGES ARE REFERRED TO B-BUS.
3. OPERATING GRID BIAS 'EG' IS THE DIFFERENCE BETWEEN THE FILAMENT CENTER VOLTAGE AND THE GRID RETURN VOLTAGE FOR EACH TUBE.

Figure 22.1. Radio Receiver R-520A/URR, arc and bias system.

TM877-CI-12

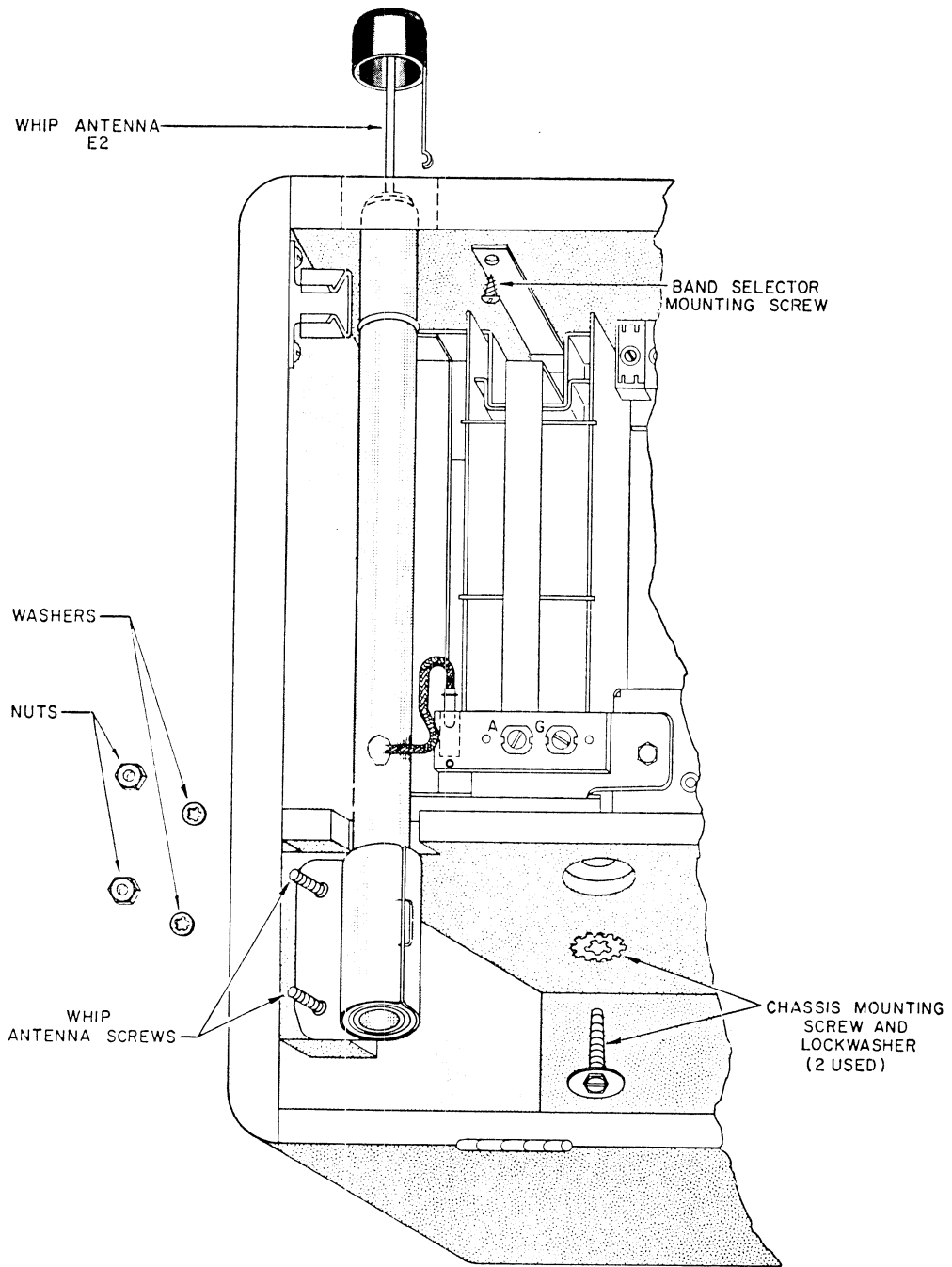

TM877-CI-13

Figure 26.1. Radio Receiver R-520A/URR, chassis removal.

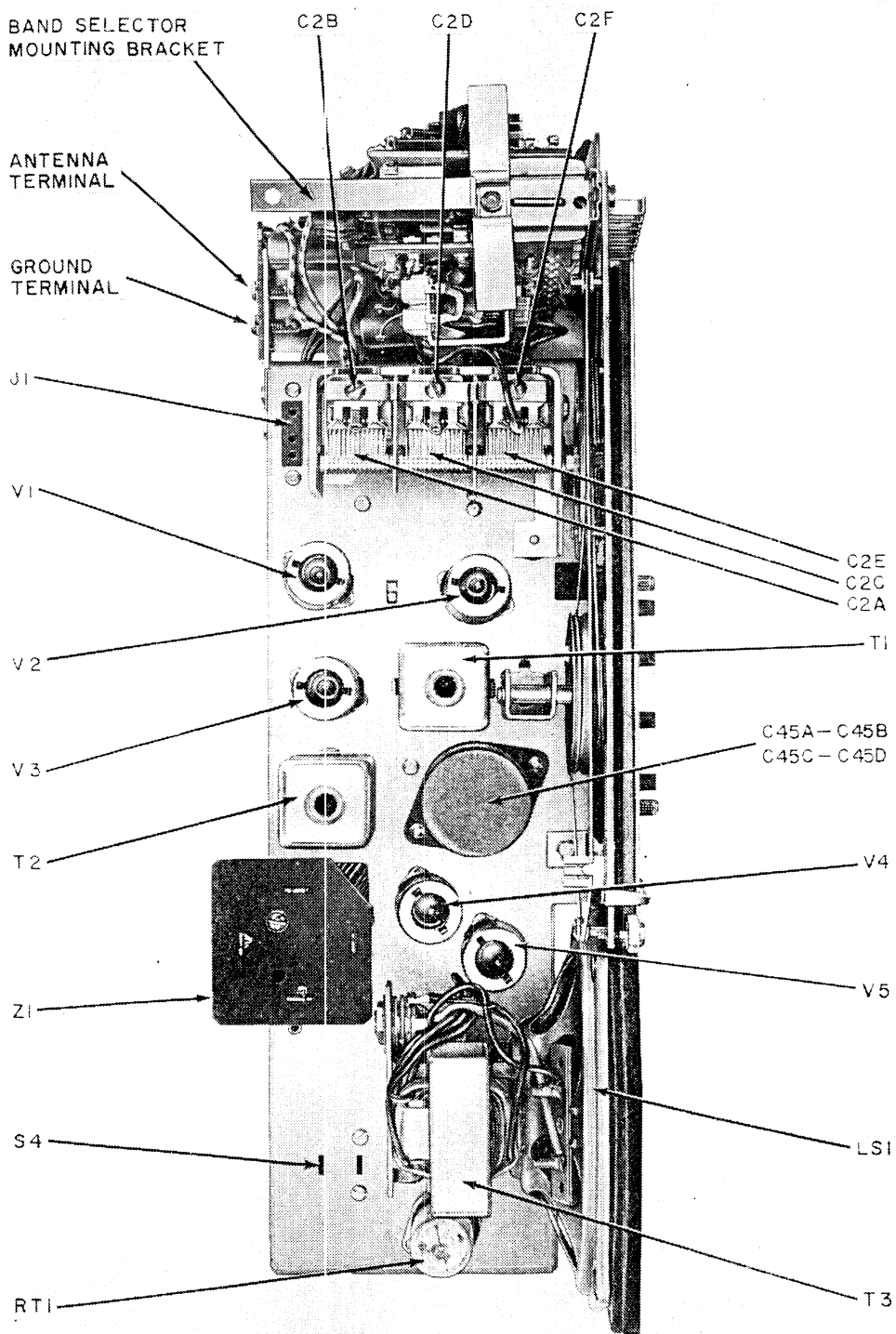

TM877-CI-14

Figure 28.1. Radio Receiver R-520A/URR, top view of chassis.

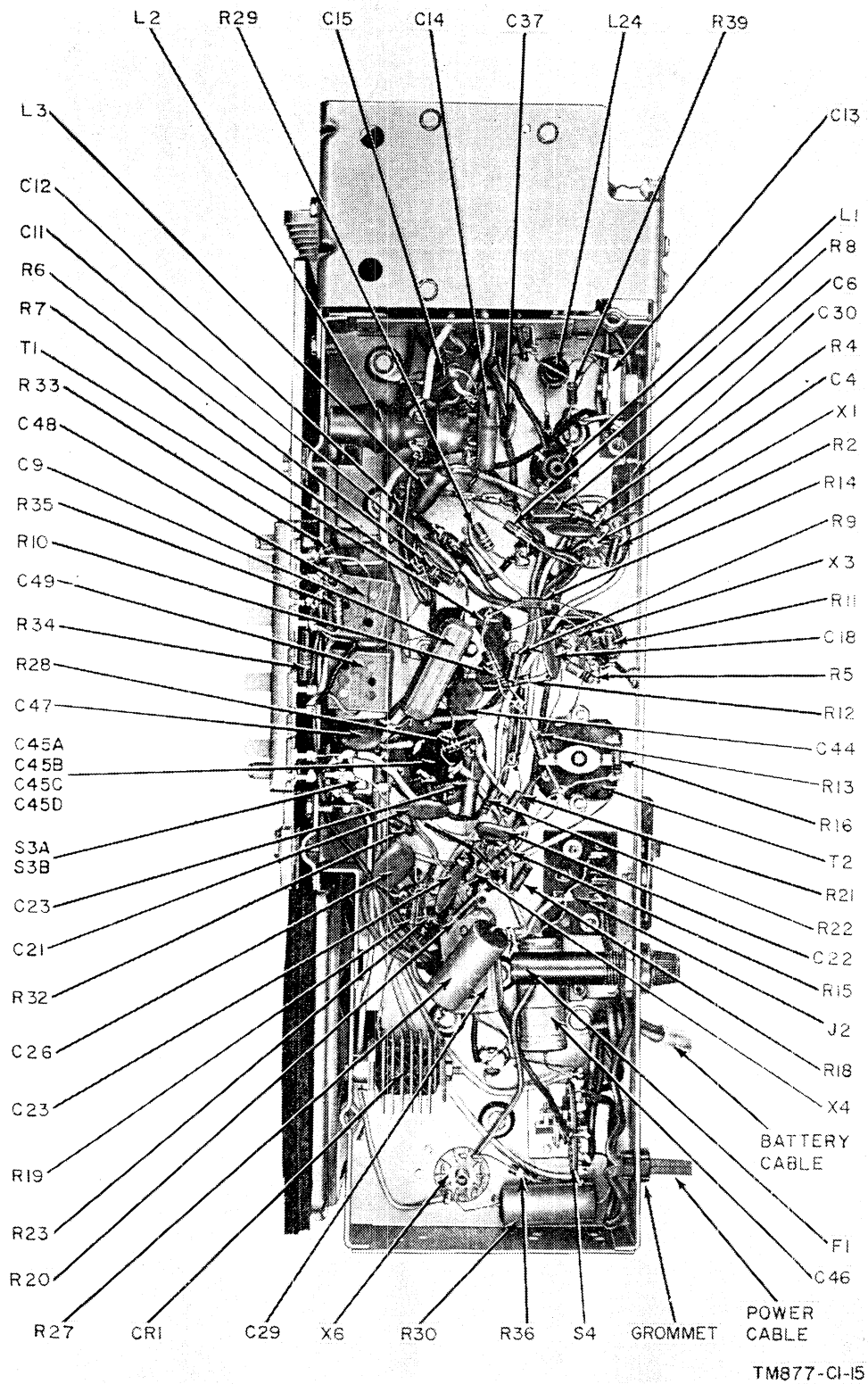
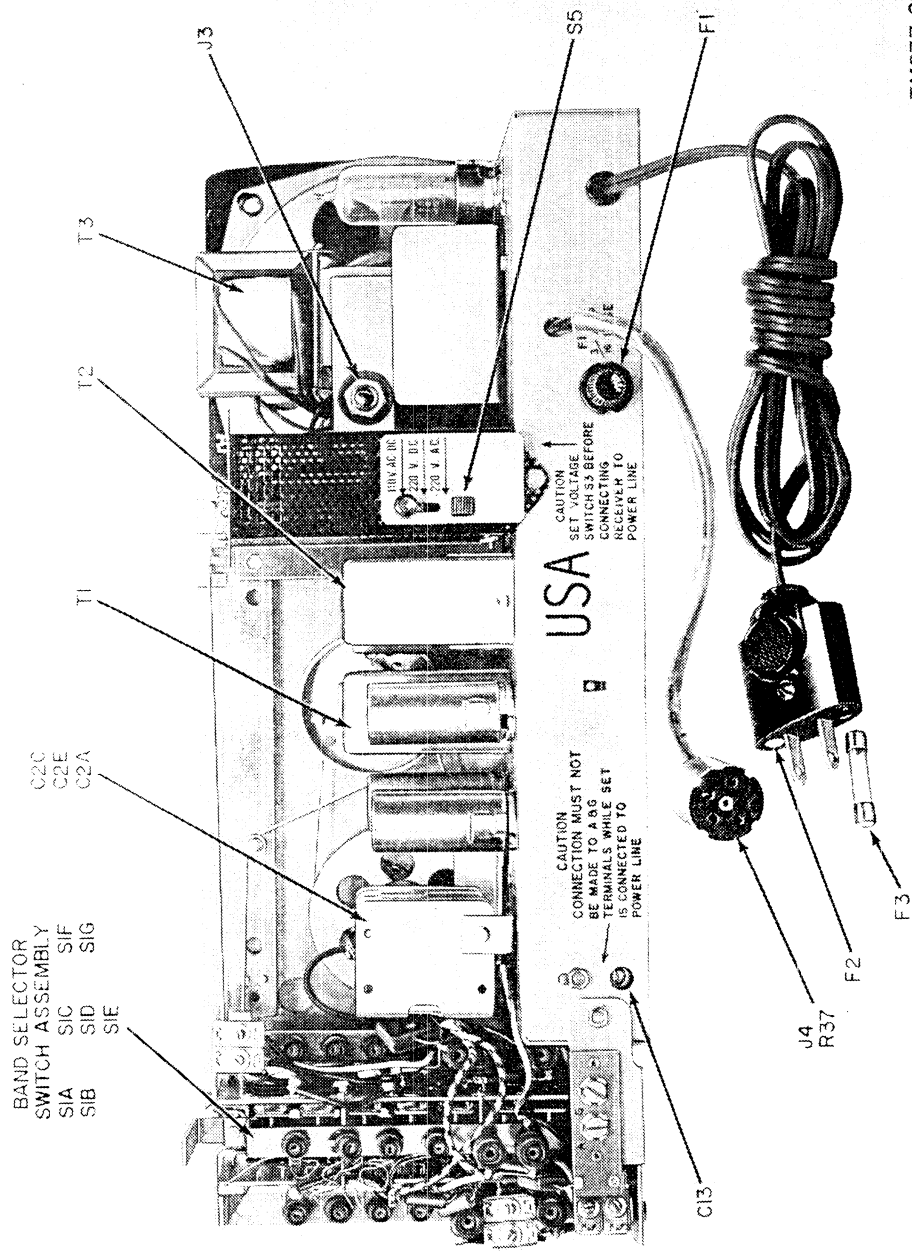
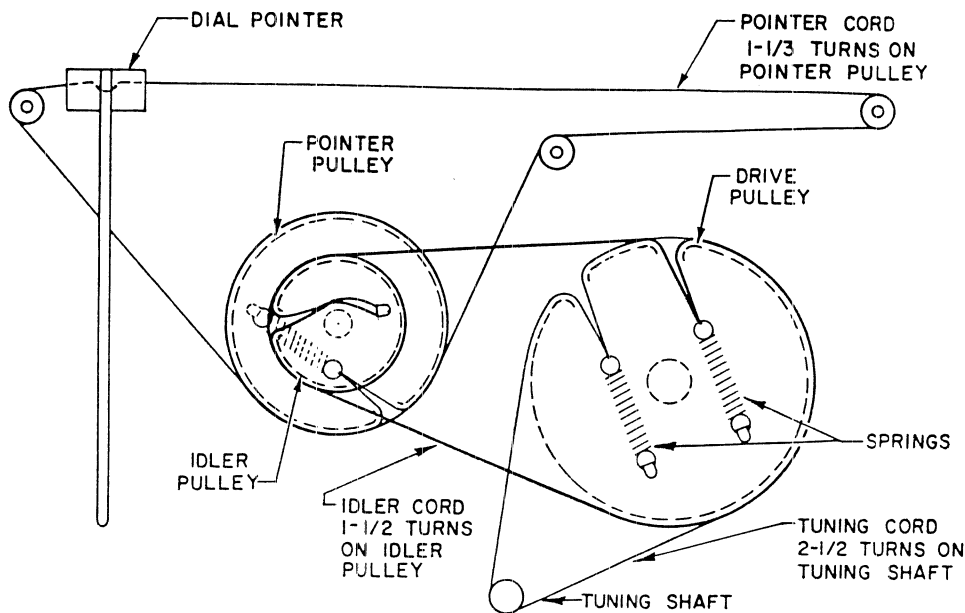

Figure 29.1. Radio Receiver R-520A/URR, bottom view of chassis.



TM877-CI-16

Figure 30.1. Radio Receiver R-520A/URR, rear view of chassis.



TM877-CI-17

Figure 32.1. Dial cord drive system for Radio Receiver R-520A URR.

connecting the spring to the pointer. To calibrate the dial pointer, set the tuning capacitor at full mesh and set the pointer at zero on the logging scale located at the top of the dial face.

Page 84. Insert figure 32.1 after figure 32.

Page 88, paragraph 84. In subparagraph *m*, add “(and fig. 16.1)” after “figure 34.”

Pages 89, 91, and 93. Add the following to the title of figures 34, 35, and 36: “(Radio Receiver R-520/URR only).”

Page 90, paragraph 85. In subparagraph *m*, add “(and fig. 17.1)” after “figure 35.”

Page 92, paragraph 90. In subparagraph *g*, add “(and fig. 18.1)” after “figure 36.”

Page 99, figure 37. Add the following to the note on figure 37: IN RADIO RECEIVER R-520A/URR, CENTER AND POSITION THE RECEIVER LOOP ANTENNA (RECEIVER LOOP IN NORMAL POSITION INSIDE TOP OF CABINET) AT RIGHT ANGLES TO THE WINDING OF THE TEST LOOP. MAKE THE DISTANCE FROM THE CENTER OF BOTH LOOPS EQUAL TO  $19\frac{3}{4}$  IN.

Page 103, paragraph 103. Add the following to subparagraph *f*: (In Radio Receiver R-520A/URR, red harness W4, black harness W6, and the cloth bag are not supplied.)

Pages 108 to 125. Delete appendix II.

Page 128. Insert figure 40.1 after figure 40.

[AG 413.44 (10 Nov 55)]

RF AMPLIFIER

V1  
1U4

CONVERTER

V2  
1L6

I F AMPLIFIER

V3  
1U4

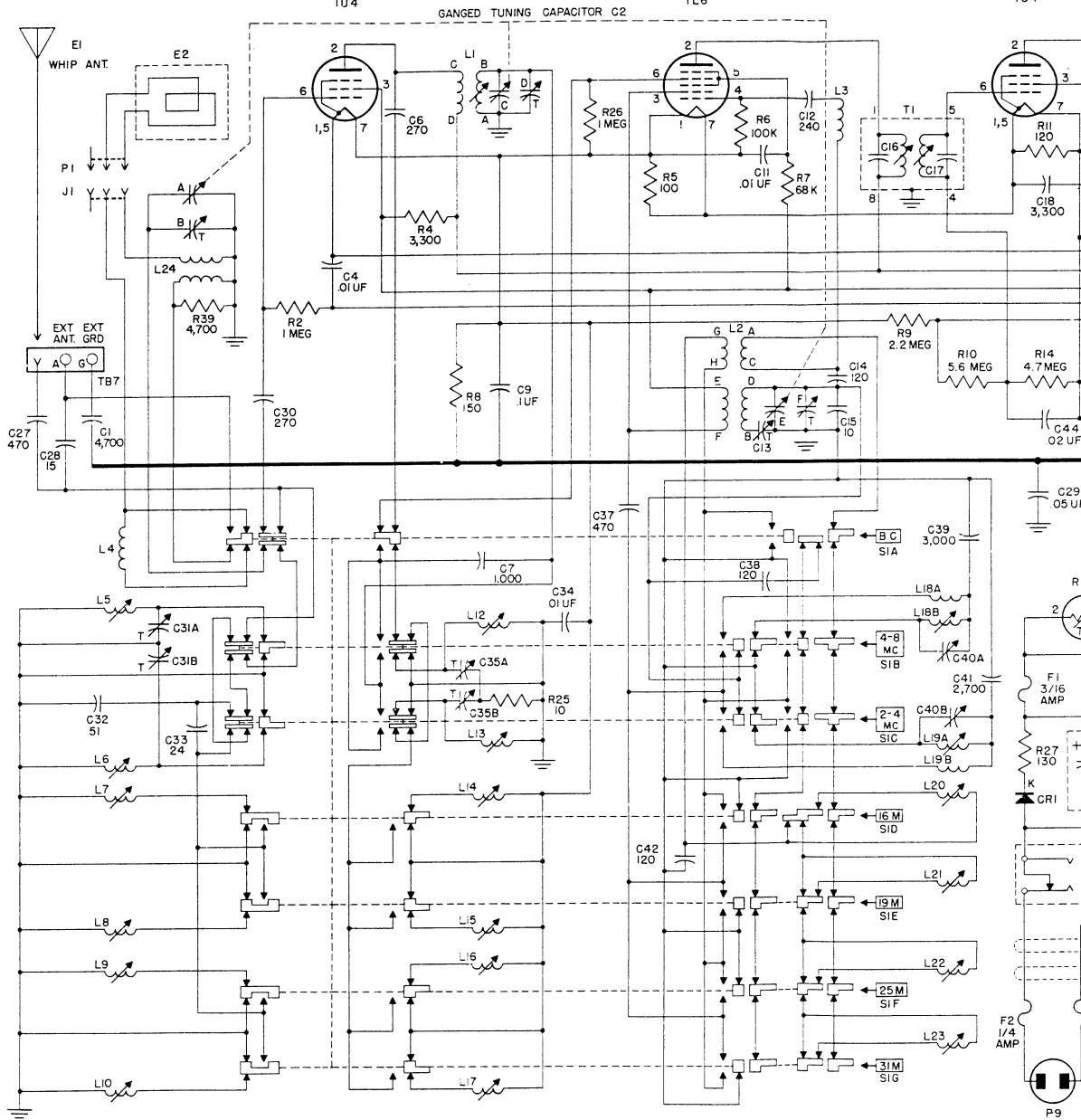



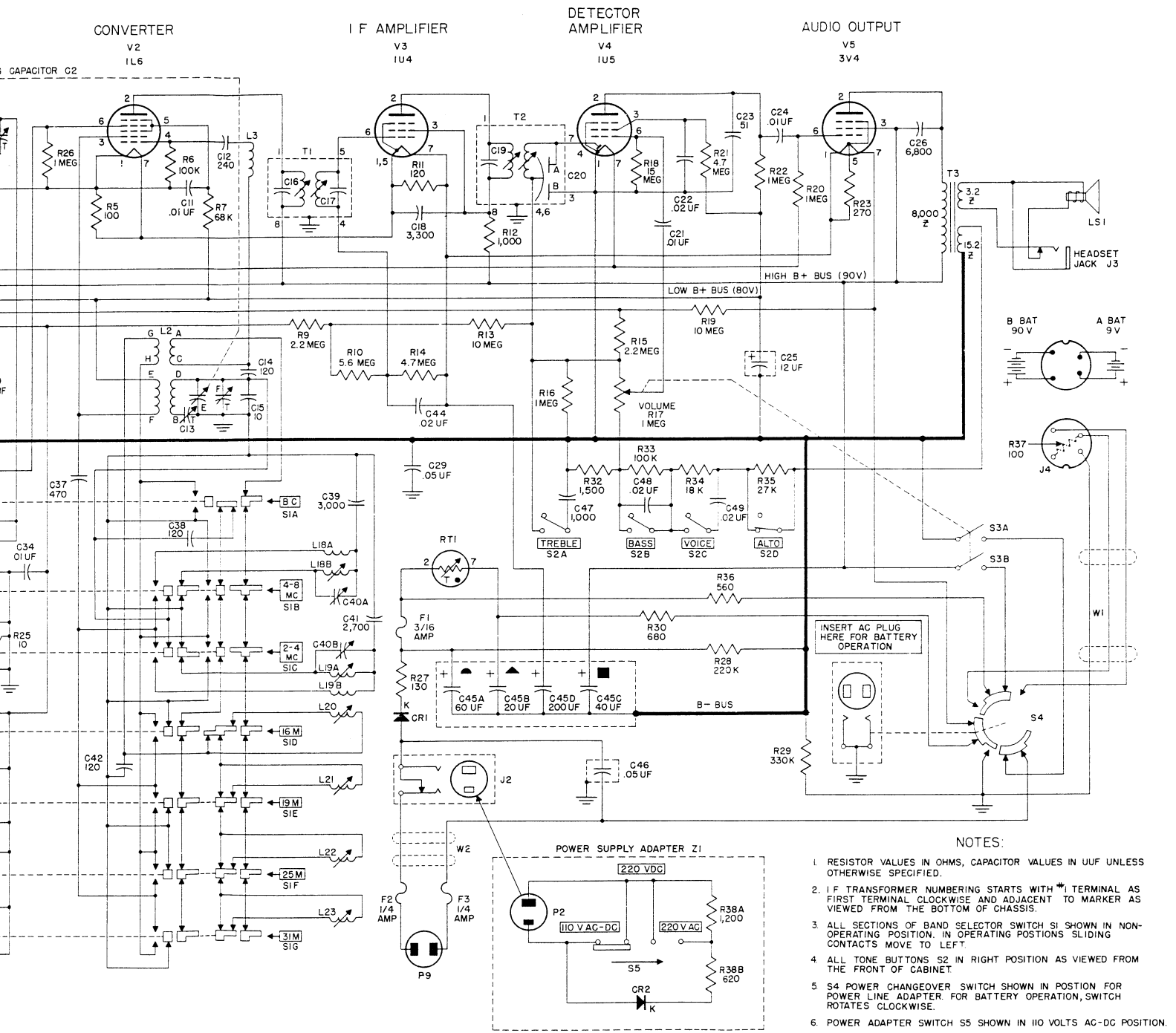

- NOTES:**
1. RESISTOR VALUES IN OHMS, CAPACITOR VALUES IN UUF UNLESS OTHERWISE SPECIFIED.
  2. I F TRANSFORMER NUMBERING STARTS WITH \*1 TERMINAL AS FIRST TERMINAL CLOCKWISE AND ADJACENT TO MARKER AS VIEWED FROM THE BOTTOM OF CHASSIS.
  3. ALL SECTIONS OF BAND SELECTOR SWITCH S1 SHOWN IN NON-OPERATING POSITION. IN OPERATING POSITIONS SLIDING CONTACTS MOVE TO LEFT.
  4. ALL TONE BUTTONS S2 IN RIGHT POSITION AS VIEWED FROM THE FRONT OF CABINET.
  5. S4 POWER CHANGEOVER SWITCH SHOWN IN POSITION FOR POWER LINE ADAPTER. FOR BATTERY OPERATION, SWITCH ROTATES CLOCKWISE.
  6. POWER ADAPTER SWITCH S5 SHOWN IN 110 VOLTS AC-DC POSITION.
  7. LETTER 'K' AT RECTIFIER SYMBOL INDICATES CATHODE TERMINAL.

Figure 40.1. Radio Receiver R-520A/URR, schematic diagram.

BY ORDER OF THE SECRETARY OF THE ARMY:

MAXWELL D. TAYLOR,  
*General, United States Army,*  
*Chief of Staff.*

OFFICIAL:

JOHN A. KLEIN,  
*Major General, United States Army,*  
*The Adjutant General.*

DISTRIBUTION:

*Active Army:*

CNGB (1)	Trans Terminal Comd (2)
Tec Svc, DA (1) except CSIGO	OS Sup Agencies (2)
(30)	Sig Fld Maint Shops (3)
Tec Svc Bd (1)	Sig Lab (5)
Hq CONARC (5)	Mil Dist (1)
CONARC Bd (Incl ea Test Sec)	Units organized under following
(1)	TOE's:
Army AA Comd (2)	11-7R, Sig Co, Inf Div (2)
OS Maj Comd (5)	11-16R, Hq & Hq Co, Si
OS Base Comd (5)	Corps or Abn Corps (2)
Log Comd (5)	11-57R, Armd Sig Co (2)
MDW (1)	11-127R, Sig Rep Co (2)
Armies (5)	11-128R, Sig Depot Co (2)
Corps (2)	11-500R (AA-AE), Sig Svc
Tng Div (2)	Org (2)
Ft & Cp (2)	11-557R, Abn Sig Co (2)
Gen & Br Svc Sch (5) except Sig	11-587R, Sig Base Maint Co (2)
Sch (25)	11-592R, Hq & Hq Co, Sig
Gen Depots (2) except Atlanta	Base Depot (2)
Gen Depot (None)	11-597R, Sig Base Depot Co (2)
Sig Sec, Gen Depots (10)	12-17R, Sp Svc Co (2)
Sig Depots (20)	

*NG:* State AG (6); units—same as Active Army except allowance is one copy to each unit.

*USAR:* None.

For explanation of abbreviations used, see SR 320-50-1.

